

3M™ Locator Plate 3443-107N

Instructions for the assembly of .100" x .100" preassembled socket connectors

1.0 General

The 3M Locator Plate 3443-107N is designed to aid in the assembly of the preassembled socket connector family for all positions. End-to-end as well as daisy chain length (min daisy chain length ± 45 mm). Set-up and assembly instructions are based on termination procedures with 3M manual and pneumatic presses.

Locator plate includes:

- Instruction sheet
- 3 mounting screws
- 1 M571x26 Hex Key
- 1 SW 2.5 56x18 Hex Key

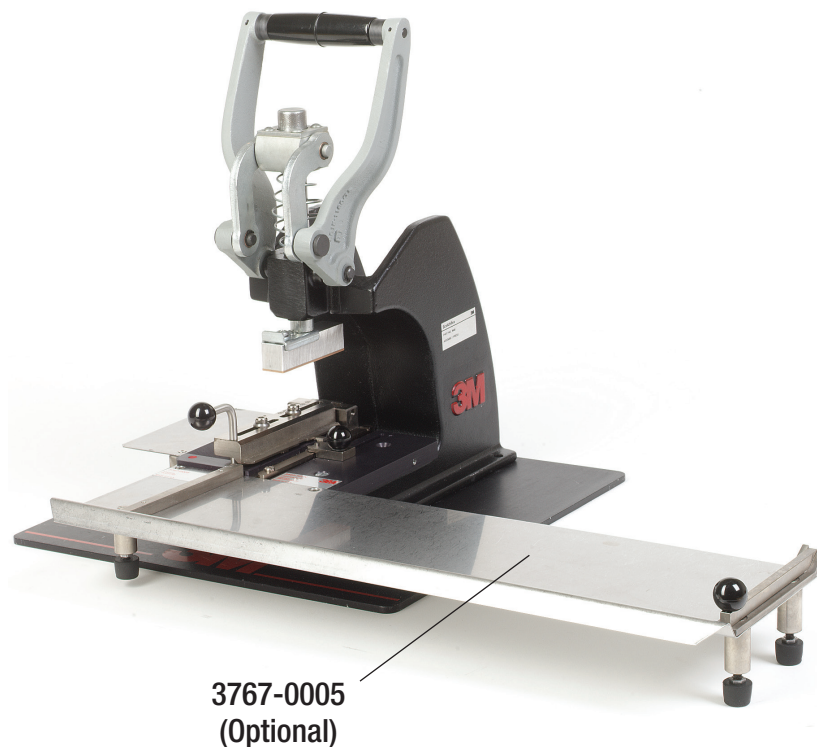

Figure 1

2.0 Tool Preparation

- 2.1 Mount lever ① on the guiding wing ② and secure by locking screw ③. Make sure that the plastic ball is facing towards the operator (see Figure 2).
- 2.2 Remove the platen from the assembly press. Adjust shut height to 17 for the 3M™ Assembly Press 3640, or to 17½ for presses the 3M™ Assembly Presses 3335 and 3316 using shut height gauge 3436-1B. The the 3M™ Assembly Press 3830 shut height is self-adjusting.
- 2.3 Place the locator plate on the press and fasten it with the two locking screws, that are included.

Note: *If the optional 3M™ Staging Platform (part number 3767-0005) is used, please refer to its own instruction sheet for mounting.*

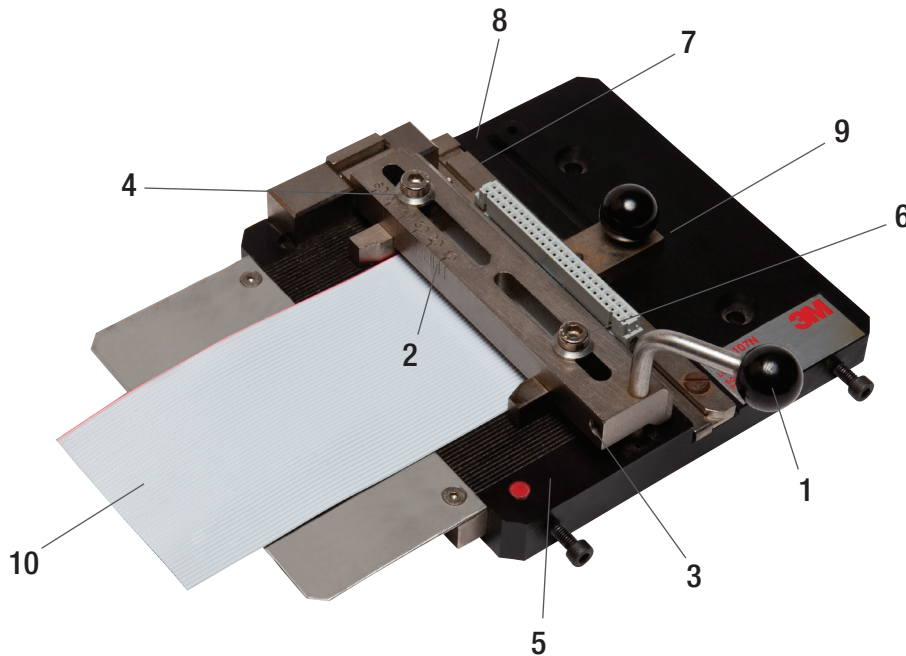

Figure 2

3.0 Assembly Procedure

- 3.1 Cut cable to the required length.
- 3.2 Loosen the left cable guide screw ④. Lift the guiding wing ② and slide the left cable guide ④ into the required position depending on the connector size to be used. Connector pole sizes are indicated on the guiding wing ②. Lower the guiding wing ② and make sure that the serrations of the base plate ⑤ and cable guide ④ are fully aligned. Tighten the cable guide locking screw.
- 3.3 Insert the appropriate cable ⑩ under guiding wing ② and adjust the right cable guide ⑥. Make sure that the base plate ⑤ and cable guide ⑥ serrations are aligned and that the right cable guide ⑥ is as close as possible to the cable ⑩.
- 3.4 Adjust the cable stop as required (see Figure 1). For daisy chain assemblies: left position ⑧. For end-to-end assemblies: right position ⑨.
- 3.5 Install the proper platen (3442-9) onto the press.
- 3.6 Remove the connector from the packing strip cover down, IDCs facing down towards the plate.

- 3.7 Slide the connector into the guiding groove against the connector locator stop ⑦.
- 3.8 Place the cable ⑩ into the base plate serrations. For end-to-end assemblies, smoothly slide the cable between cable guides ④ ⑥, under the guiding wing ② against cable stop ⑨. For daisy chain assemblies, until the required length is obtained. The cable will fit between the cover and the contacts of the connector.

Note: If the cable is not entering into the connector smoothly, check the flatness of the cable used.

- 3.9 Complete the assembly by closing the press handle.

Note: Never operate a pneumatic press without ensuring that there is a connector in the locator plate.

- 3.10 Raise the press handle and remove the finished assembly by lifting the guiding wing ② with the lever ①.
- 3.11 Visually inspect to ensure that: a) The cover is fully locked. If not, check the shut height gauge.
b) The cable is correctly aligned in the cover. If not, check the cable guide adjustment.

3M is a trademark of 3M Company.

Important Notice

All statements, technical information, and recommendations related to 3M's products are based on information believed to be reliable, but the accuracy or completeness is not guaranteed. Before using this product, you must evaluate it and determine if it is suitable for your intended application. You assume all risks and liability associated with such use. Any statements related to the product which are not contained in 3M's current publications, or any contrary statements contained on your purchase order shall have no force or effect unless expressly agreed upon, in writing, by an authorized officer of 3M.

Warranty; Limited Remedy; Limited Liability.

This product will be free from defects in material and manufacture for a period of 90 days from the time of purchase. **3M MAKES NO OTHER WARRANTIES INCLUDING, BUT NOT LIMITED TO, ANY IMPLIED WARRANTY OF MERCHANTABILITY OR FITNESS FOR A PARTICULAR PURPOSE.** If this product is defective within the warranty period stated above, your exclusive remedy shall be, at 3M's option, to replace or repair the 3M product or refund the purchase price of the 3M product. **Except where prohibited by law, 3M will not be liable for any indirect, special, incidental or consequential loss or damage arising from this 3M product, regardless of the legal theory asserted.**



**Electronic Solutions Division
Interconnect Products**

6801 River Place Blvd.
Austin, TX 78726-9000
800-225-5373
www.3Mconnectors.com

Please recycle. Printed in USA.
© 3M 2012
78-9101-4048-8-B