

Fiber Optic Receiver

OPF2412, OPF2412T

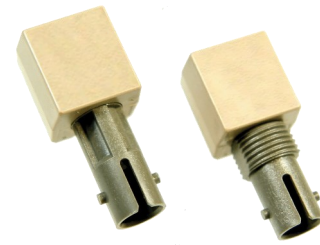

Features:

- Up to 5Mbps operation
- 850nm wavelength
- ST⁰ style port
- CMOS and TTL compatible
- Wave solderable
- Wide temperature range

Description:

The OPF2412 family is a low cost digital output fiber optic receiver. The lensed optical system keeps the receiver response consistent for all fiber sizes which makes it ideal for use on fibers as small as 50/125µm. The design incorporates a monolithic photo-IC comprised of a photodetector and DC amplifier driving an open collector output Schottky transistor. The output makes the OPF2412 compatible with TTL and CMOS logic. The receiver is designed to operate from a single +5 V supply. A bypass capacitor (0.1µF ceramic) should be connected from V_{CC} to GND of the receiver.

Applications:

- Industrial Ethernet equipment
- Copper-to-fiber media conversion
- Intra-system fiber optic links
- Video surveillance systems

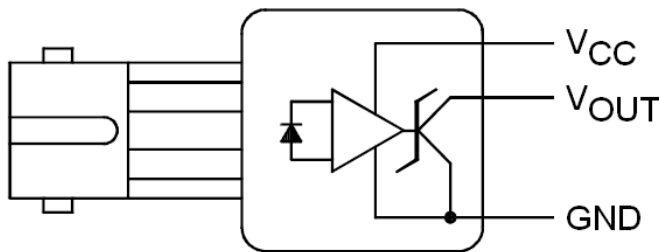

“T” suffix = Threaded ST⁰ package

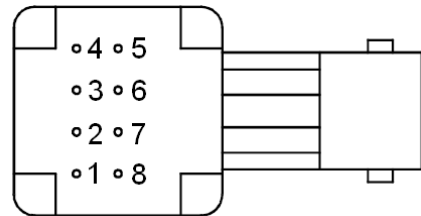

PIN	FUNCTION
1	Not Connected
2	V _{CC}
3	GND
4	Not Connected
5	Not Connected
6	V _{OUT}
7	GND
8	Not Connected

Pins 3 & 7 are electrically connected to the header.
Pins 1,4,5 & 8 are mechanically connected together.



RoHS



ESD Class 2

ST⁰ is a registered trademark of AT&T.

General Note

TT Electronics reserves the right to make changes in product specification without notice or liability. All information is subject to TT Electronics' own data and is considered accurate at time of going to print.

Fiber Optic Receiver

OPF2412, OPF2412T



Mechanical Data

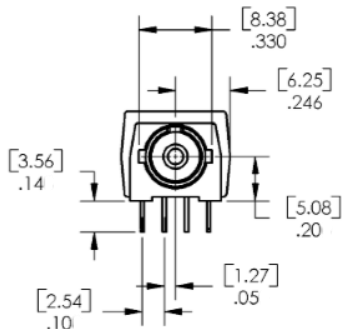
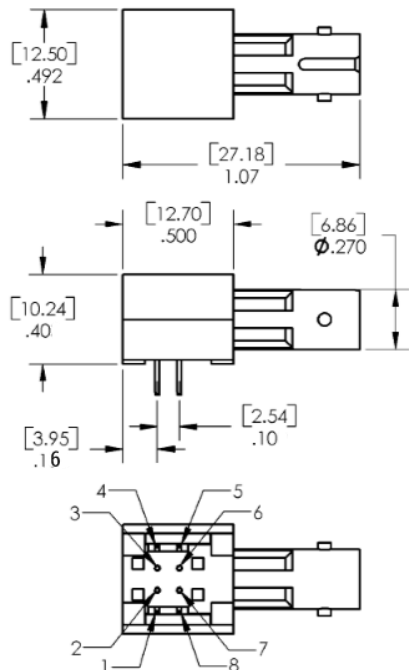

PINS 1, 4, 5, & 8 - .020 X .015
[0.51 X 0.38]
PINS 2, 3, 6, & 7 - Ø.018
[0.46]

OPF2412

OPF2412T

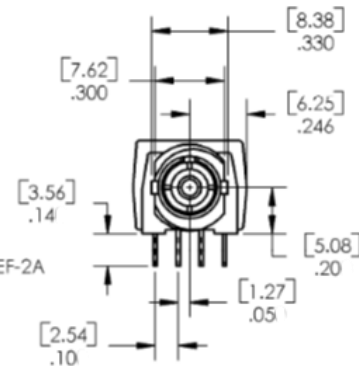
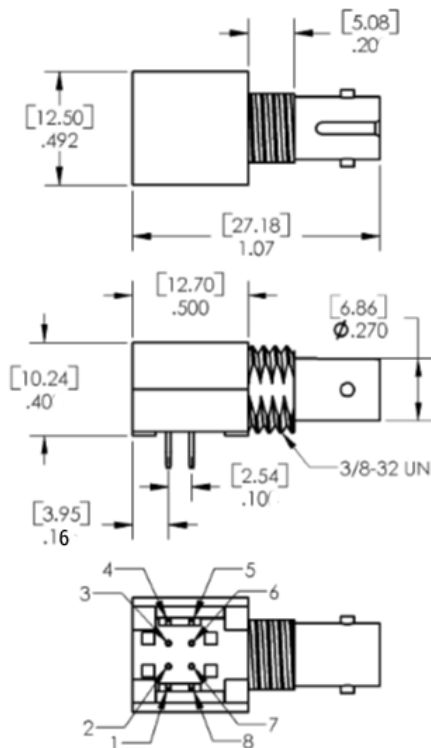

PINS 1, 4, 5, & 8 - .020 X .015
[0.51 X 0.38]
PINS 2, 3, 6, & 7 - Ø.018
[0.46]

3 place decimals ± .005
2 place decimals ± .01

DIMENSIONS ARE IN: [MILLIMETERS]
INCHES

General Note

TT Electronics reserves the right to make changes in product specification without notice or liability. All information is subject to TT Electronics' own data and is considered accurate at time of going to print.

TT Electronics | OPTEK Technology
2900 E. Plano Pkwy, Plano, TX 75074 | Ph: +1 972 323 2200
www.ttelectronics.com | sensors@ttelectronics.com

Electrical Specifications

Absolute Maximum Ratings (T_A = 25° C unless otherwise noted)

Storage Temperature Range	-55° C to +85° C
Operating Temperature Range	-40° C to +85° C
Lead Soldering Temperature ⁽¹⁾	260° C
Supply Voltage	-0.5 V to 7.0 V
Output Current	25 mA
Output Voltage	-0.5 V to 18.0 V
Open Collector Power Dissipation	40 mW
Fan Out (TTL)	5 ⁽²⁾

Electrical Characteristics (T_A = 25° C unless otherwise noted)

SYMBOL	PARAMETER	MIN	TYP	MAX	UNITS	TEST CONDITIONS
I _{OH}	High Level Output Current		5	250	μA	V _O = 18 V, P _R < -40 dBm
V _{OL}	Low Level Output Voltage		0.4	0.5	V	I _O = 8 mA, P _R > -24 dBm
I _{CCH}	High Level Supply Current		3.5	6.3	mA	V _{CC} = 5.25 V, P _R < -40 dBm
I _{CCL}	Low Level Supply Current		6.2	10	mA	V _{CC} = 5.25 V, P _R > -24 dBm
P _{RH}	Peak Input Power Level, Logic HIGH			0.1	μW	I _p = 850 nm
P _{RL}	Peak Input Power Level, Logic LOW	2.9		120	μW	I _p = 850 nm, I _{OL} = 8 mA
P _{RL}	Peak Input Power Level, Logic LOW	4.0		100	μW	-40 °C ≤ T _A ≤ +85 °C
t _{PLHR}	Propagation Delay LOW to HIGH		65		ns	P _R = -21 dBm, Data Rate = 5 MBd
t _{PHLR}	Propagation Delay HIGH to LOW		49		ns	P _R = -21 dBm, Data Rate = 5 MBd

Notes:

- Maximum of 5 seconds with soldering iron. Duration can be extended to 10 seconds when flow soldering. RMA flux is recommended.
- 8 mA load (5 x 1.6 mA), R_L = 560 Ω.

Application Circuit

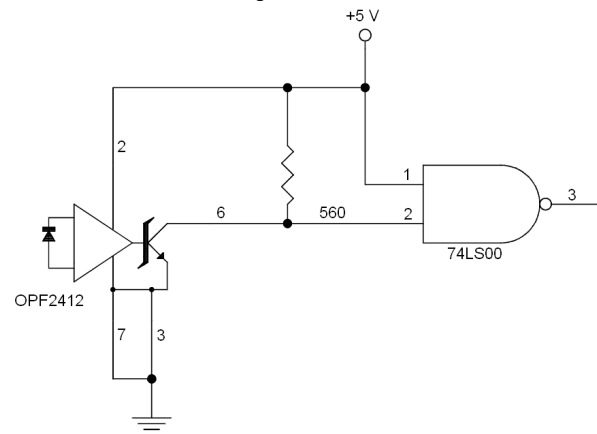

General Note

TT Electronics reserves the right to make changes in product specification without notice or liability. All information is subject to TT Electronics' own data and is considered accurate at time of going to print.