



Datasheet

Warrior II LTE/Cellular SMD

Part No:
PA.711.A

Description:

Pairs with the PA.710.A Warrior for 4G MIMO applications
698MHz to 960MHz, 1710MHz to 2690MHz, 5000 to 5850MHz

Features:

Supplied as one part of a MIMO pair with PA.710.A on MIMO applications
High isolation and ECC when used with PA.710.A on specific board layouts
High Efficiency Antenna
Patent Pending
Surface Mount Technology
Dimensions: 40x6x5mm
RoHS and REACH Compliant

1. Introduction	3
2. Specifications	4
3. Antenna Characteristics	6
4. Radiation Patterns	9
5. Mechanical Drawing	26
6. Antenna Integration Guide	27
7. Packaging	36
<hr/>	
Changelog	37

Taoglas makes no warranties based on the accuracy or completeness of the contents of this document and reserves the right to make changes to specifications and product descriptions at any time without notice. Taoglas reserves all rights to this document and the information contained herein. Reproduction, use or disclosure to third parties without express permission is strictly prohibited.



1. Introduction



The Taoglas PA.711.A is the culmination of a multi-year research effort into LTE MIMO SMD antennas. It has been designed specifically to be used as the second antenna in a 2*2 or higher MIMO setup in conjunction with our standard PA.710.A LTE antenna. The PA.711.A has all the same attributes of the PA.710.A, a high efficiency SMD Ceramic antenna, operating at 698MHz to 960MHz and 1710MHz to 2690MHz.

Due to subtle variation of radiation pattern it delivers high isolation and ECC <0.3 when used with the PA.710.A in certain layouts. This decreases the footprint required for LTE MIMO applications compared to using other antennas.

The PA.711.A is delivered on tape and reel and mounted securely during the device PCB reflow process. For further information, or assistance with integration, contact your regional Taoglas customer support team.

Note for single LTE antenna applications please use the PA.710.A.

2. Specifications

Electrical					
Frequency (MHz)	698~960	1710 ~2170	2300 ~2400MHz	2490 ~2690MHz	5000 ~5850MHz
Peak Gain	1.0dBi	2.9dBi	4.1dBi	2.8dBi	4dBi
Average Gain	-2.8dB	-2.6dB	-2.0dB	-2.2dB	-1.5dB
Efficiency	52%	54%	62%	61%	70%
VSWR	<3.0:1				
Impedance	50Ω				
Polarization	Linear				
Radiation Properties	Omni-directional				
Max Input Power	5 W				

Mechanical	
Dimensions (mm)	40 x 6 x 5 mm
Material	Ceramic
Termination	Ag (environmental-friendly Pb free)
EVB Connector	SMA-Female

Environmental	
Operation Temperature	-40°C to 85°C
Storage Temperature	-40°C to 105°C
Relative Humidity	Non-condensing 65°C 95% RH
RoHs Compliant	Yes
Moisture Sensitivity Level	3

The PA.711 antenna performance was measured with Taoglas PAD.71X.A EVB.

5G/4G Bands			
Band Number	5GNR / FR1 / LTE / LTE-Advanced / WCDMA / HSPA / HSPA+ / TD-SCDMA		
	Uplink	Downlink	Covered
1	UL: 1920 to 1980	DL: 2110 to 2170	✓
2	UL: 1850 to 1910	DL: 1930 to 1990	✓
3	UL: 1710 to 1785	DL: 1805 to 1880	✓
4	UL: 1710 to 1755	DL: 2110 to 2155	✓
5	UL: 824 to 849	DL: 869 to 894	✓
7	UL: 2500 to 2570	DL: 2620 to 2690	✓
8	UL: 880 to 915	DL: 925 to 960	✓
9	UL: 1749.9 to 1784.9	DL: 1844.9 to 1879.9	✓
11	UL: 1427.9 to 1447.9	DL: 1475.9 to 1495.9	✗
12	UL: 699 to 716	DL: 729 to 746	✓
13	UL: 777 to 787	DL: 746 to 756	✓
14	UL: 788 to 798	DL: 758 to 768	✓
17	UL: 704 to 716	DL: 734 to 746	✓
18	UL: 815 to 830	DL: 860 to 875	✓
19	UL: 830 to 845	DL: 875 to 890	✓
20	UL: 832 to 862	DL: 791 to 821	✓
21	UL: 1447.9 to 1462.9	DL: 1495.9 to 1510.9	✗
22	UL: 3410 to 3490	DL: 3510 to 3590	✗
23	UL: 2000 to 2020	DL: 2180 to 2200	✓
24	UL: 1625.5 to 1660.5	DL: 1525 to 1559	✓
25	UL: 1850 to 1915	DL: 1930 to 1995	✓
26	UL: 814 to 849	DL: 859 to 894	✓
27	UL: 807 to 824	DL: 852 to 869	✓
28	UL: 703 to 748	DL: 758 to 803	✓
29	UL: -	DL: 717 to 728	✓
30	UL: 2305 to 2315	DL: 2350 to 2360	✓
31	UL: 452.5 to 457.5	DL: 462.5 to 467.5	✗
32	UL: -	DL: 1452 - 1496	✓
35		1850 to 1910	✓
38		2570 to 2620	✓
39		1880 to 1920	✓
40		2300 to 2400	✓
41		2496 to 2690	✓
42		3400 to 3600	✗
43		3600 to 3800	✗
48		3550 to 3700	✗
66	UL: 1710-1780	DL: 2110-2200	✓
71		617 to 698	✓
74/75/76		1427 to 1518	✓
78		3300 to 3800	✗
79		4400 to 5000	✗
85	698-716	728-746	✓

3. Antenna Characteristics

3.1 Return Loss

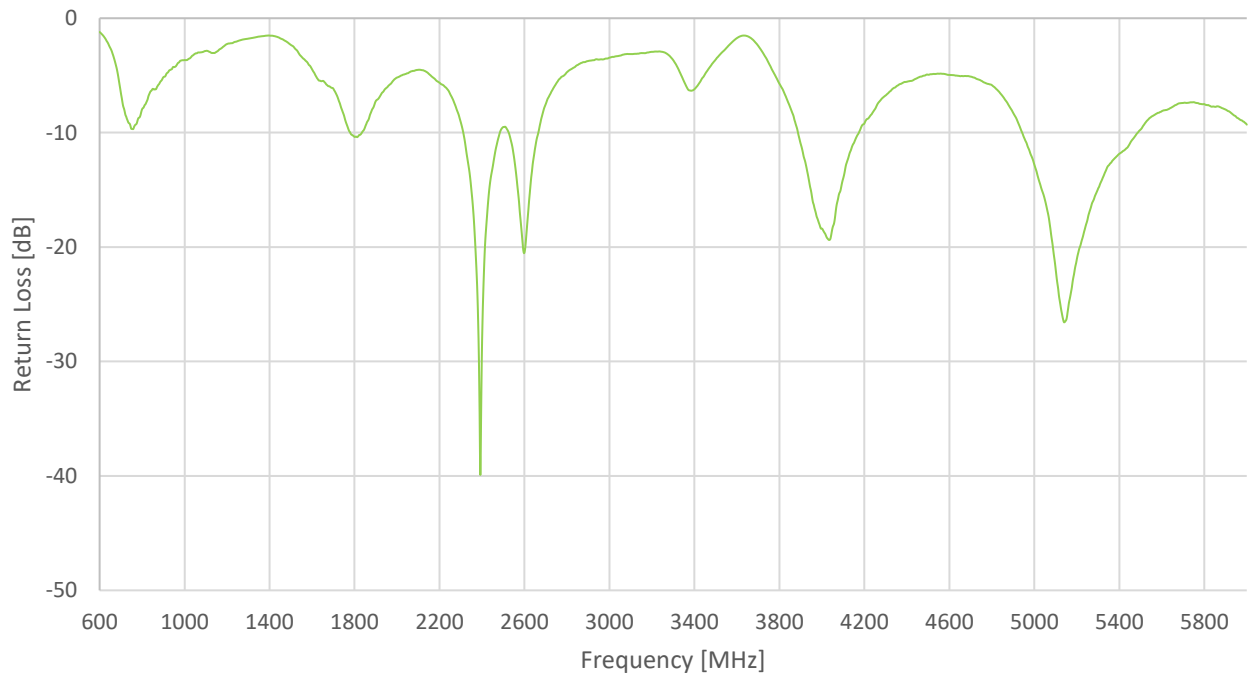

3.2 VSWR

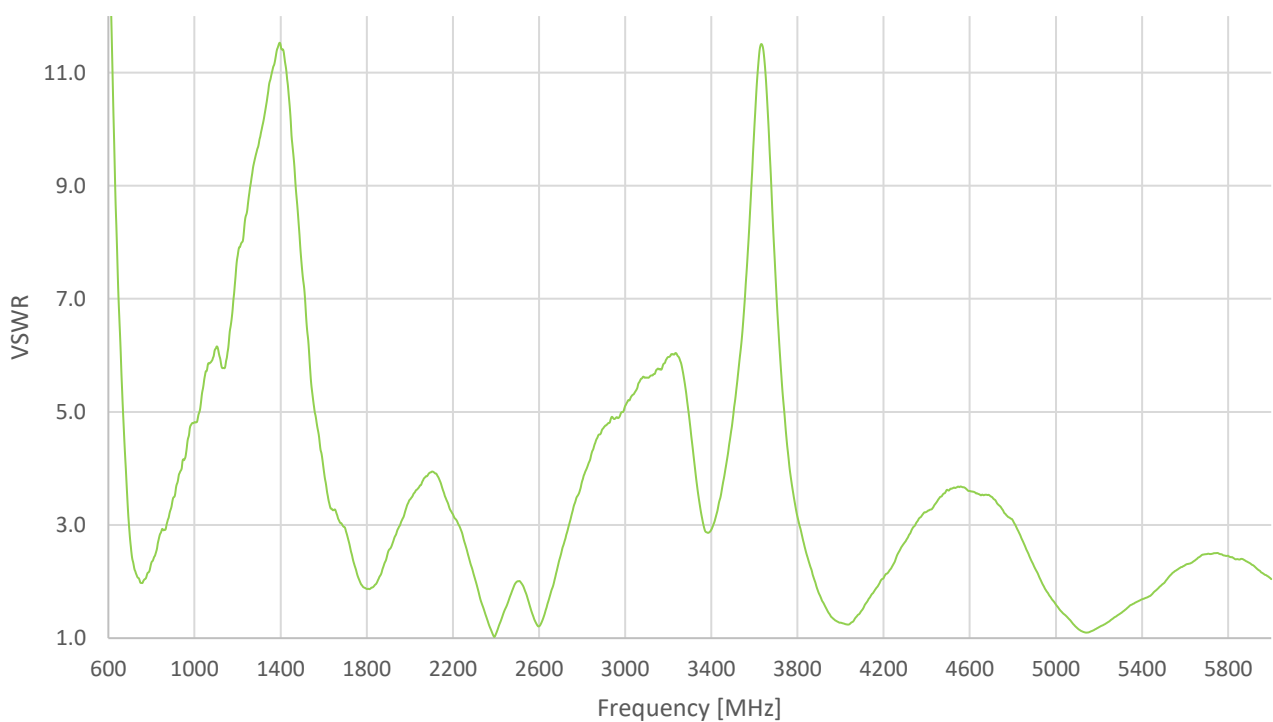

3.3 Isolation

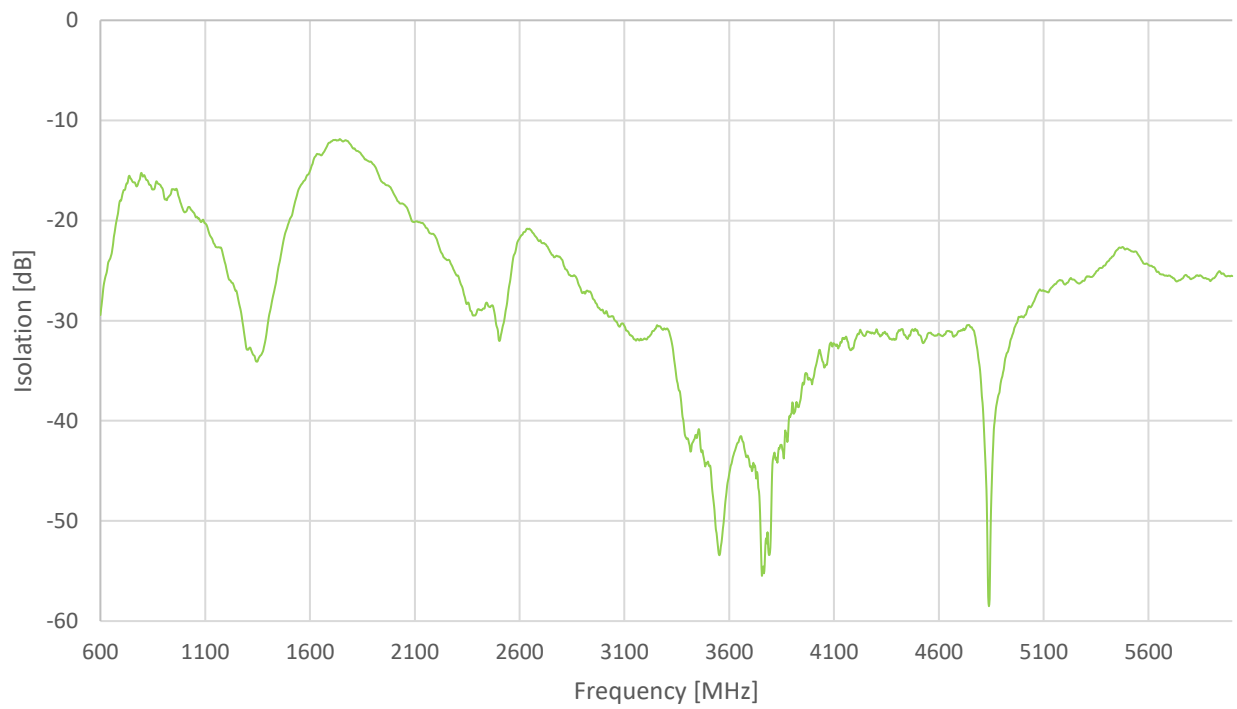

3.4 Efficiency

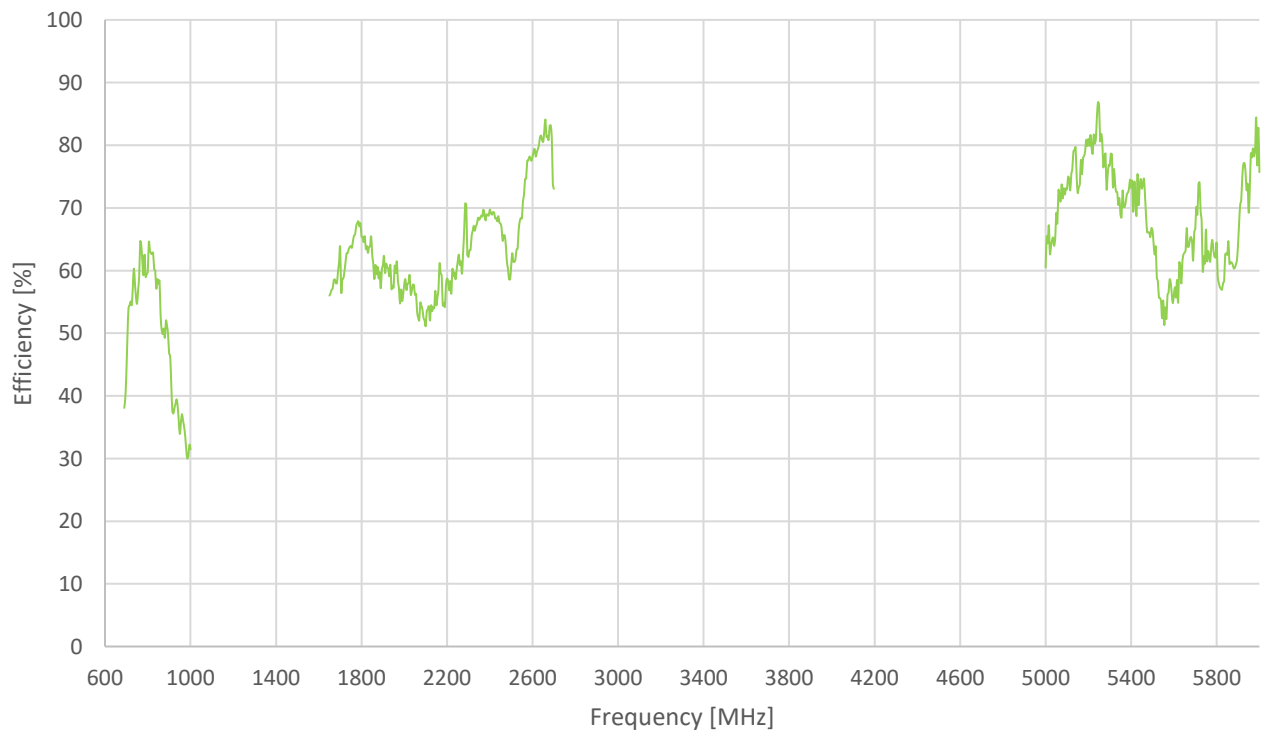

3.5 Peak Gain

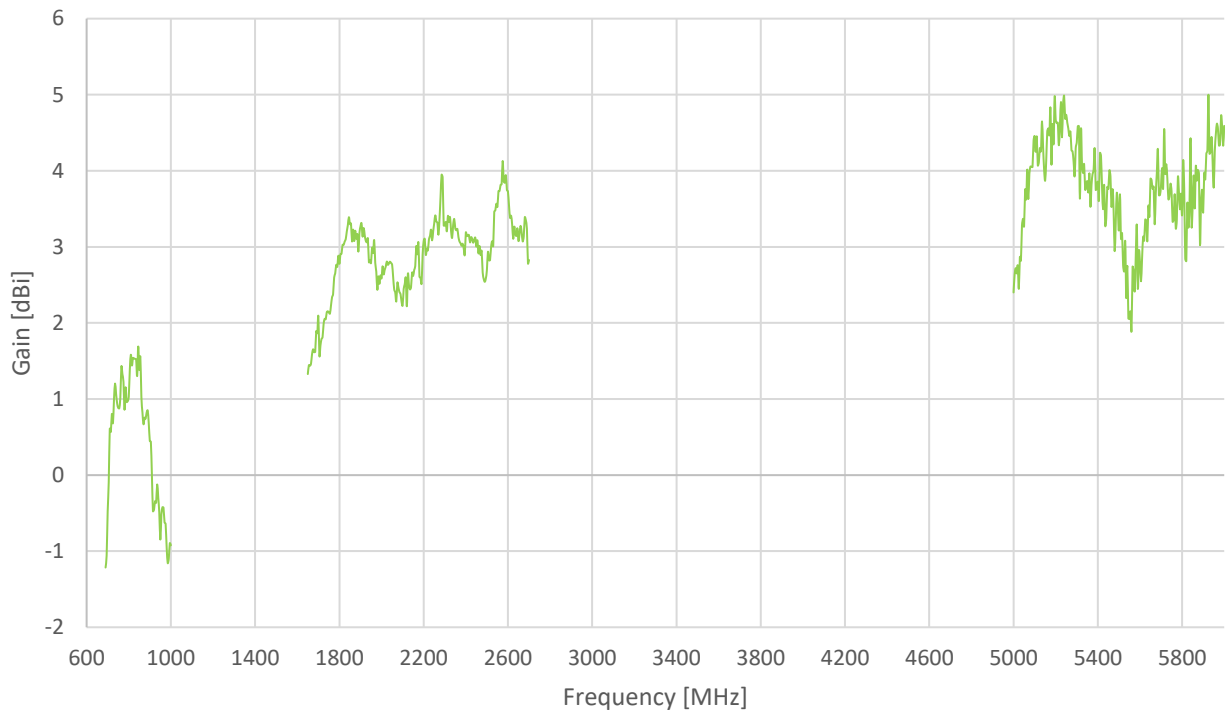

3.6 Average Gain

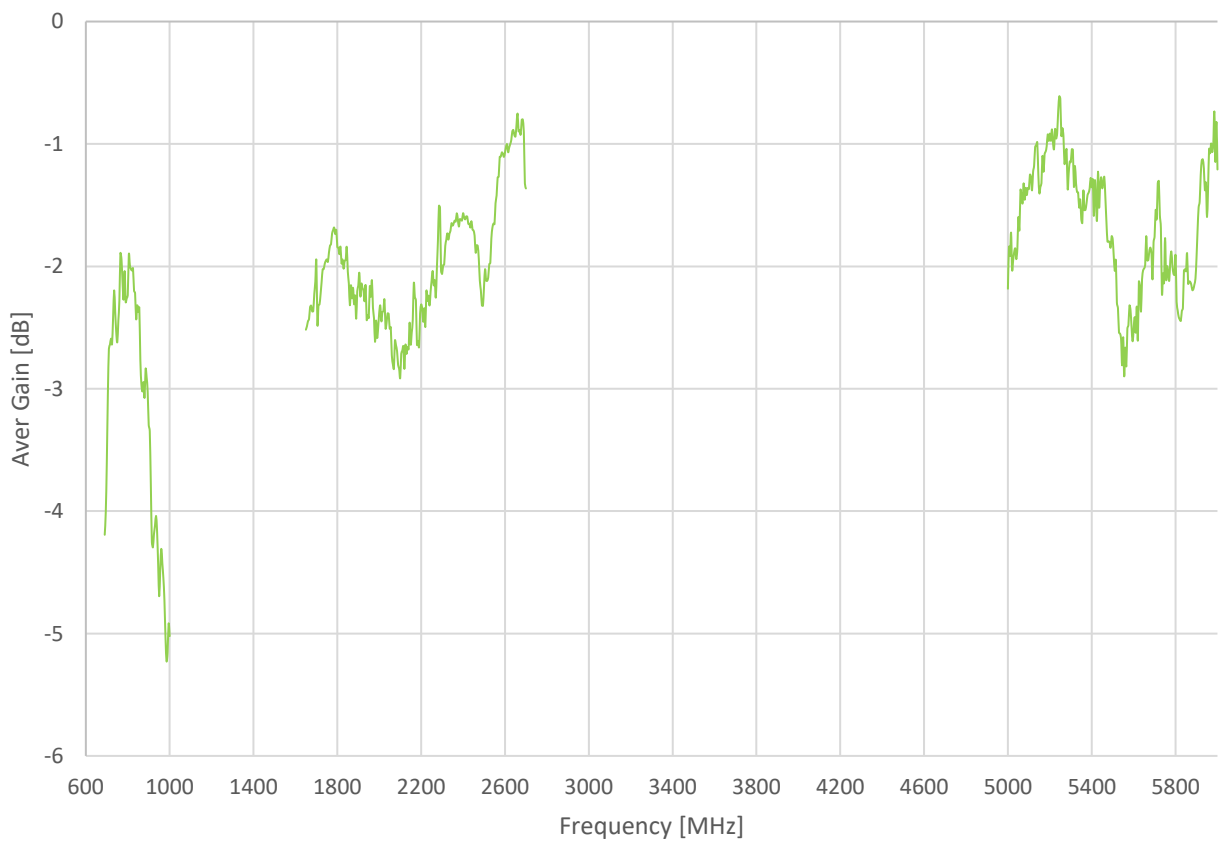

4. Radiation Patterns

4.1 Test Setup



Chamber Set-up

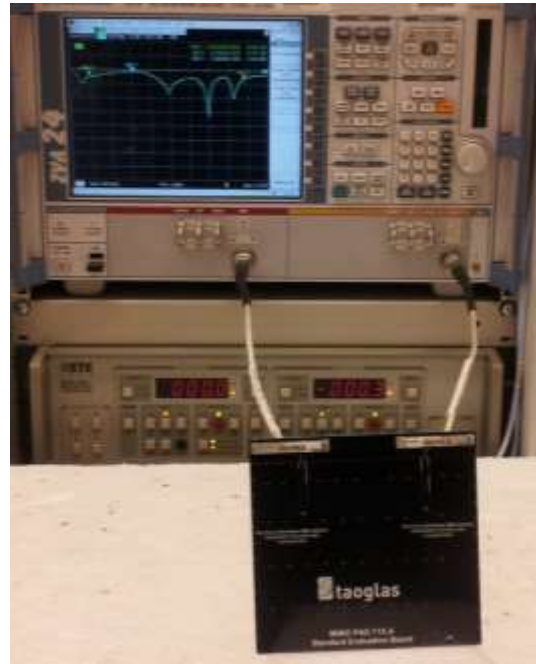

VNA Set-up

4.2 700MHz - 3D and 2D Radiation Patterns

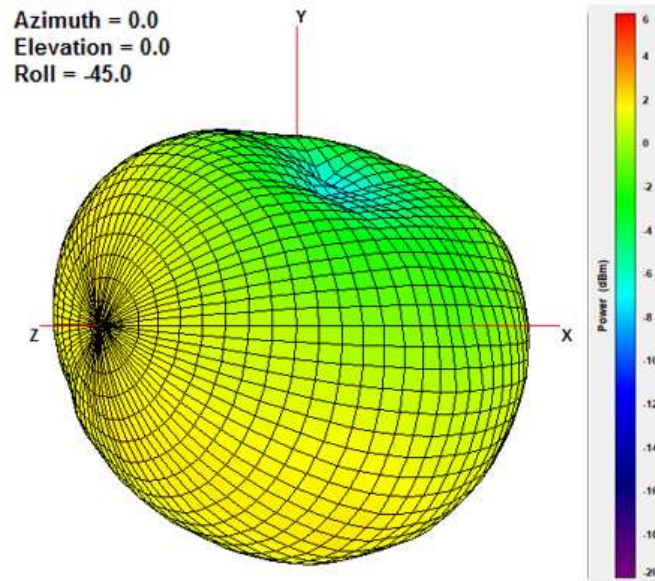

XY Plane

XZ Plane

YZ Plane

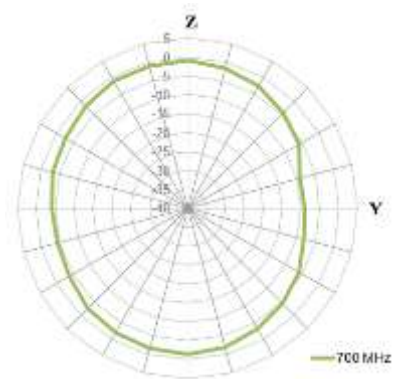
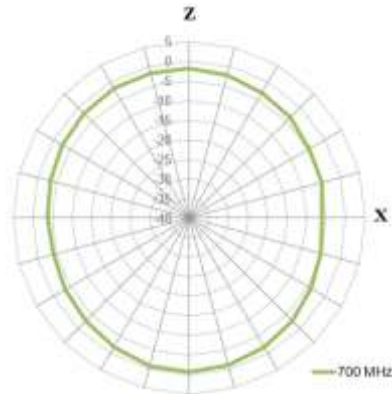
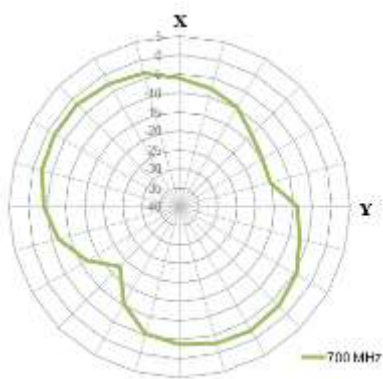

800MHz

Azimuth = 0.0
Elevation = 0.0
Roll = -45.0

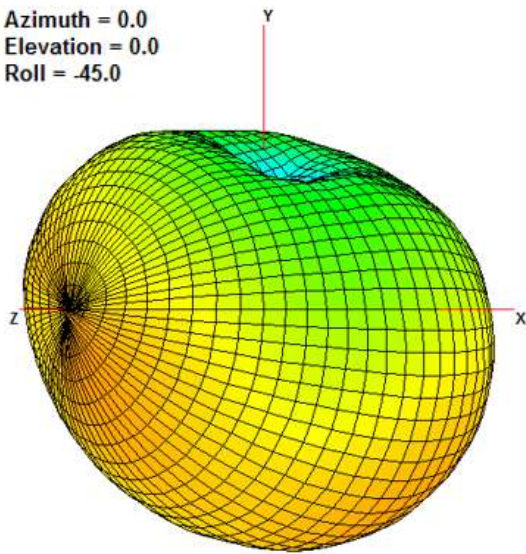

XY Plane

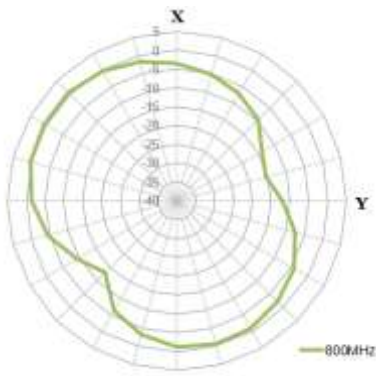

XZ Plane

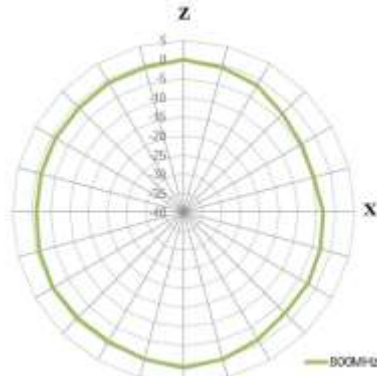

YZ Plane

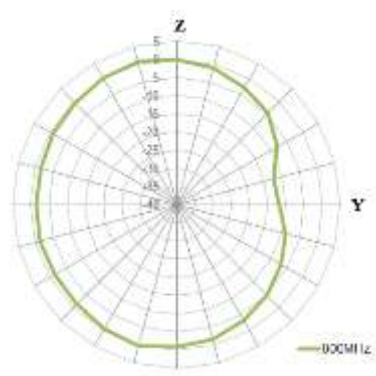

900MHz

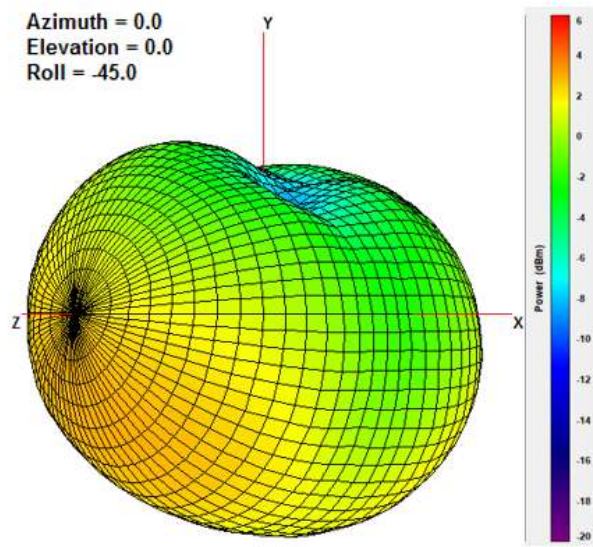

XY Plane

XZ Plane

YZ Plane

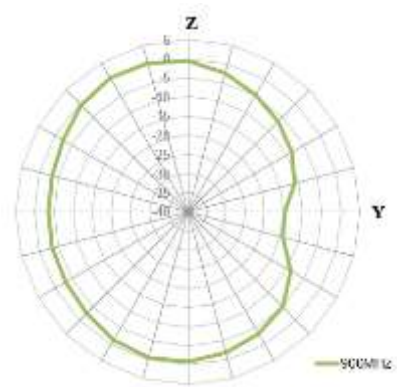
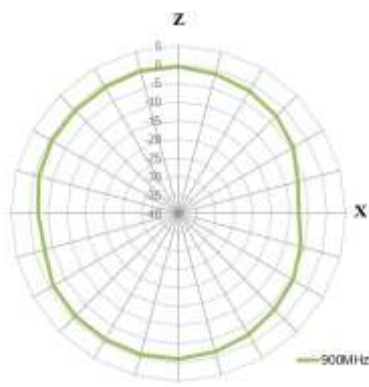
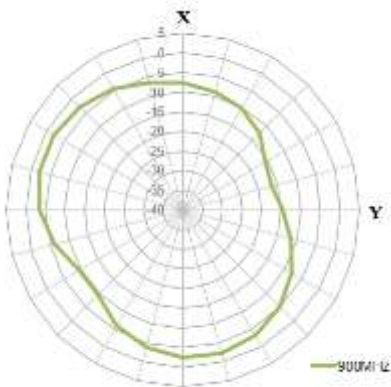

1710MHz

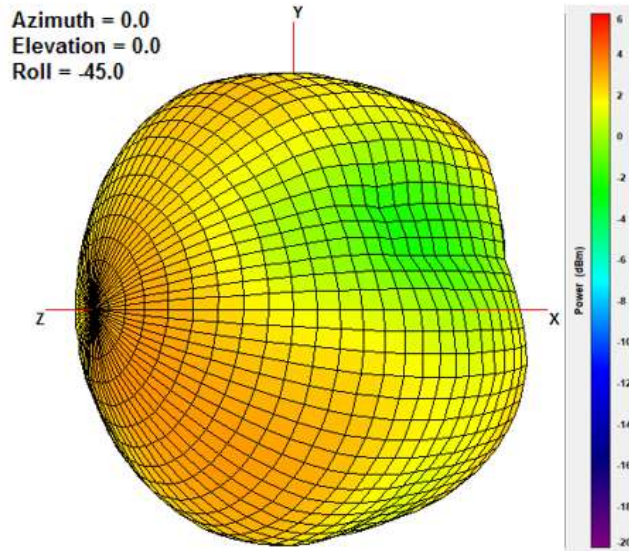

XY Plane

XZ Plane

YZ Plane

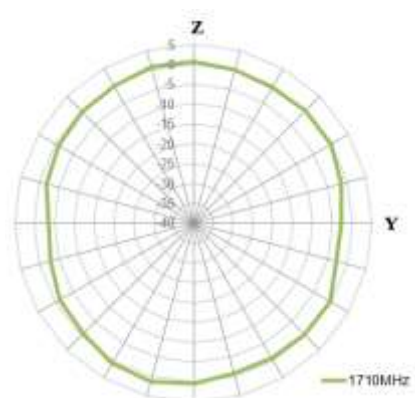
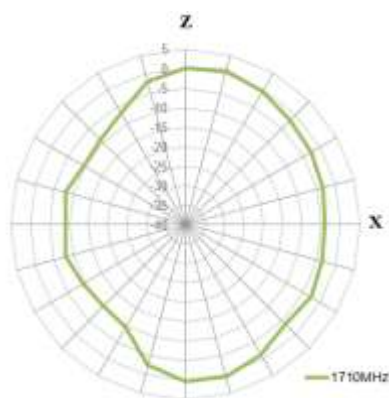
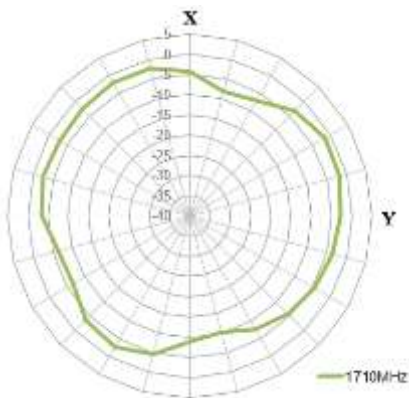

1805MHz

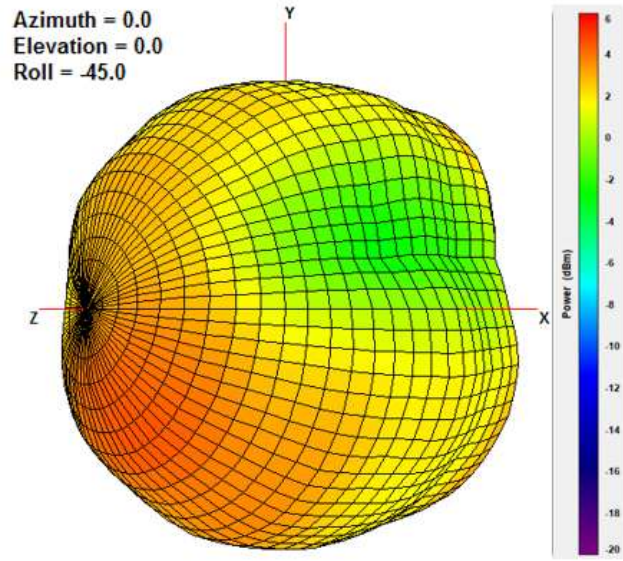

XY Plane

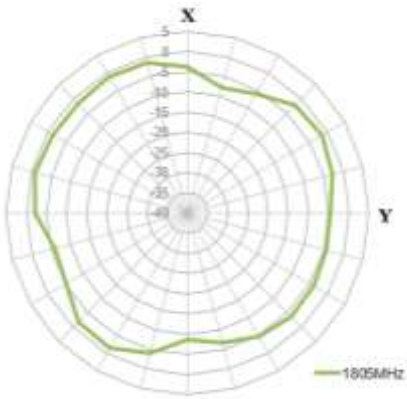

XZ Plane

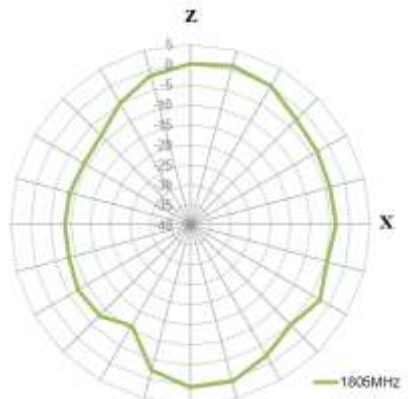

YZ Plane

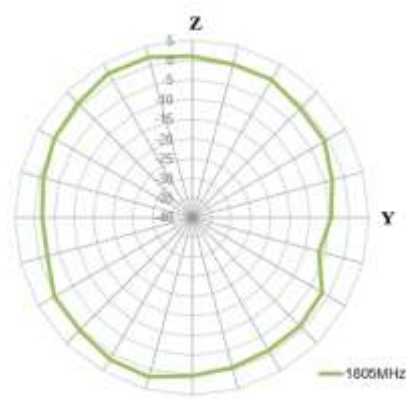

1910MHz

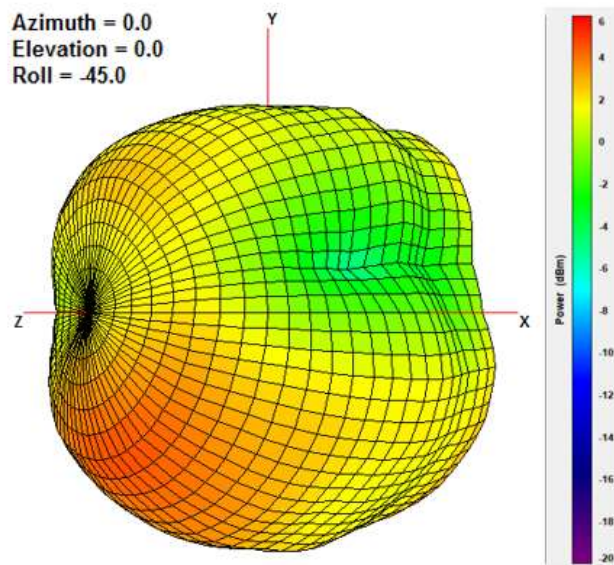

XY Plane

XZ Plane

YZ Plane

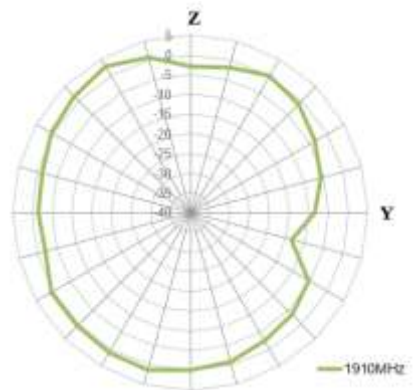
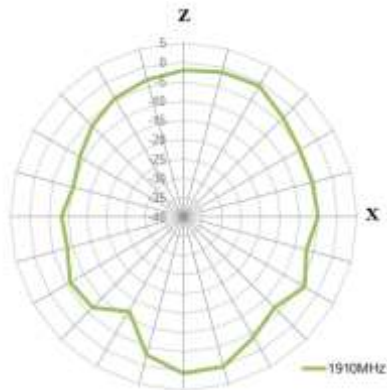
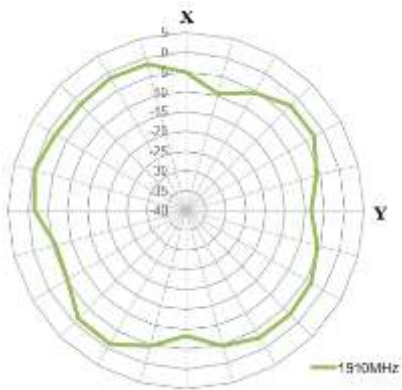

1990MHz

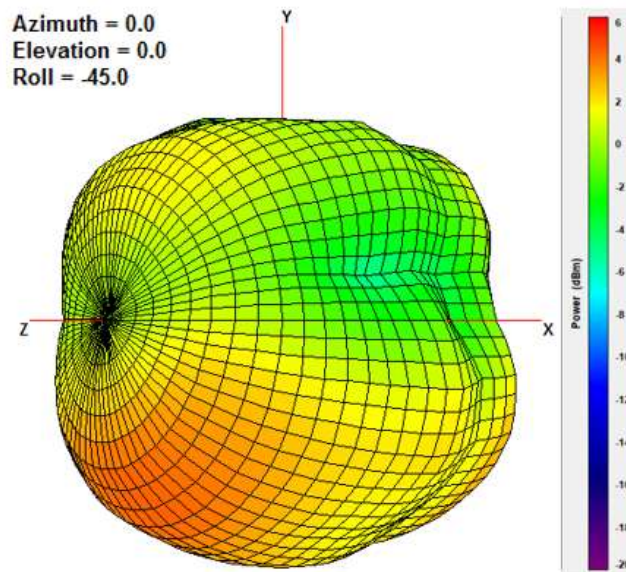

XY Plane

XZ Plane

YZ Plane

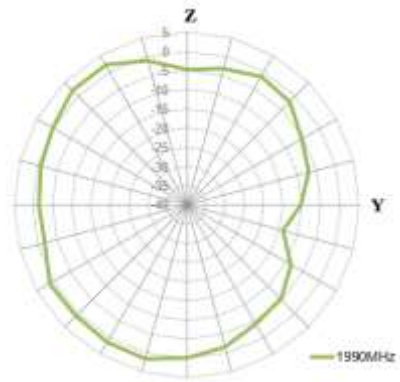
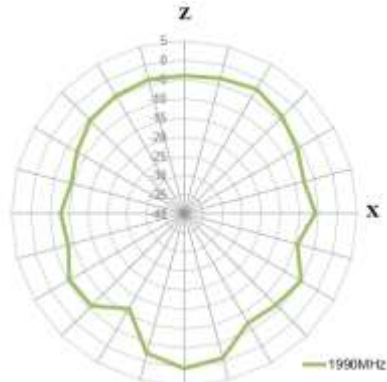
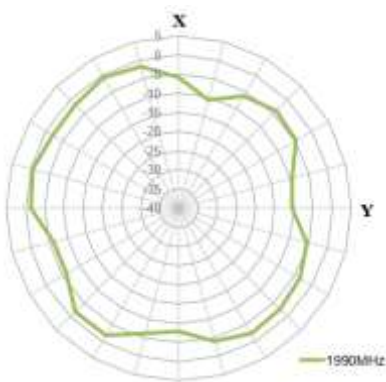

2170MHz

Azimuth = 0.0
Elevation = 0.0
Roll = -45.0

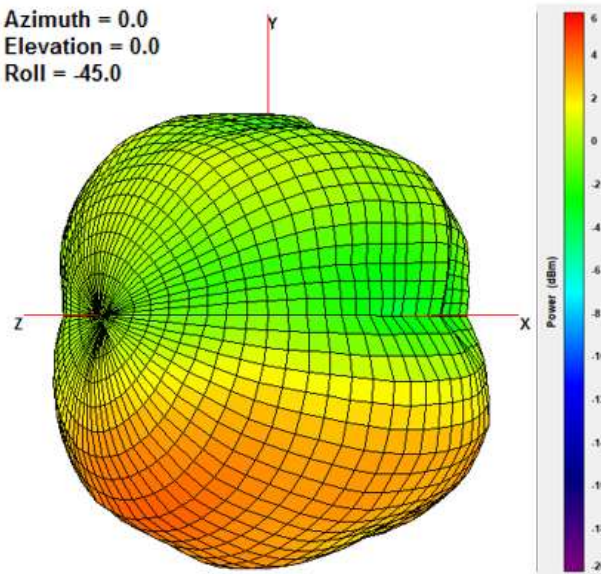

XY Plane

XZ Plane

YZ Plane

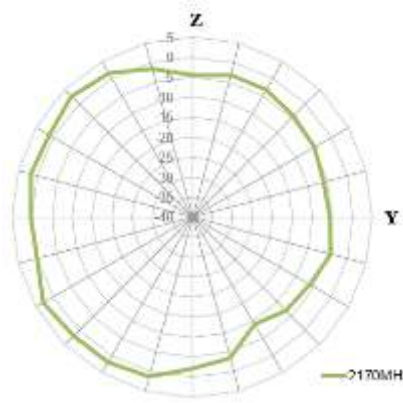
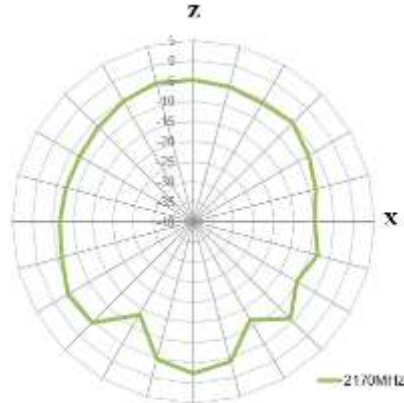
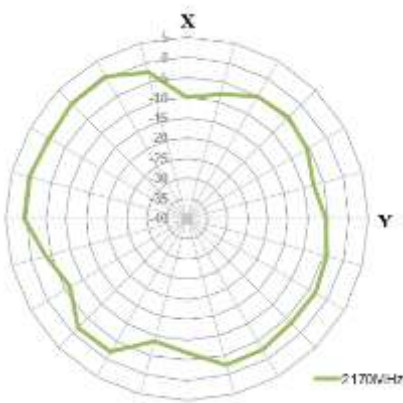

2400MHz

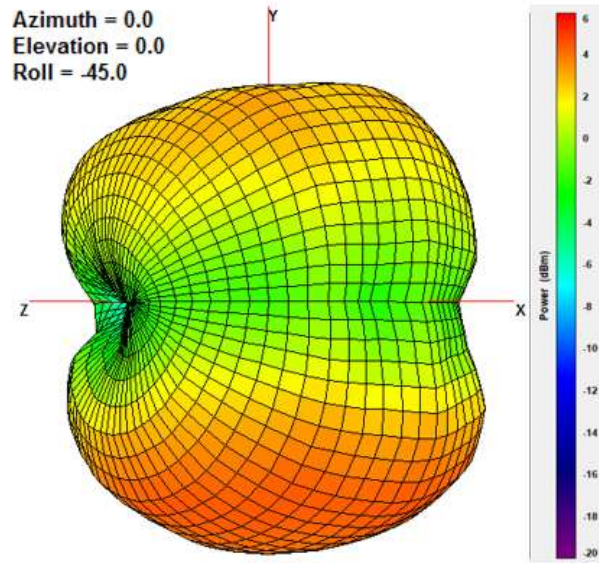

XY Plane

XZ Plane

YZ Plane

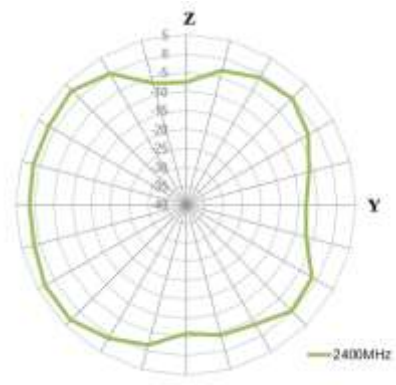
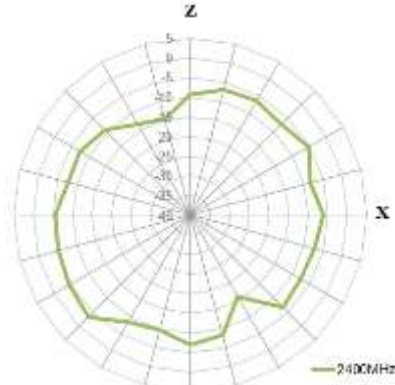
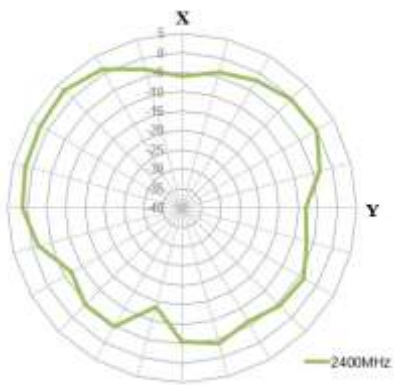

2500MHz

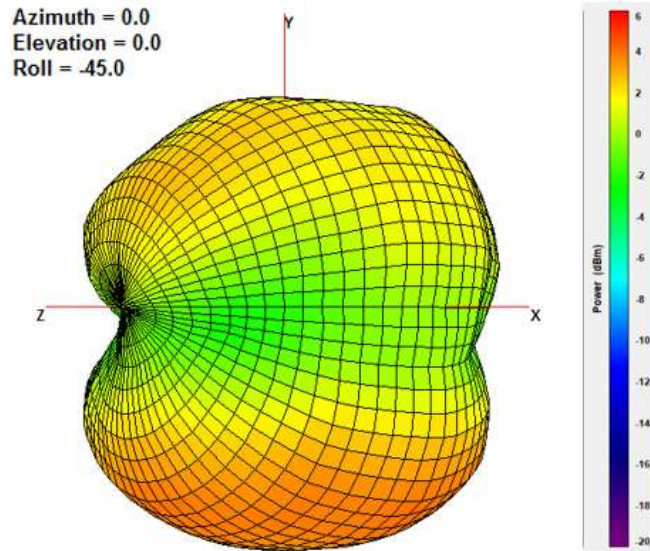

XY Plane

XZ Plane

YZ Plane

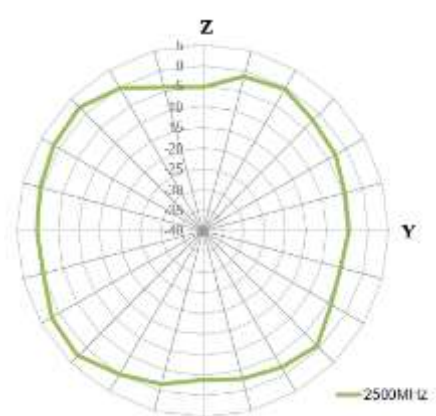
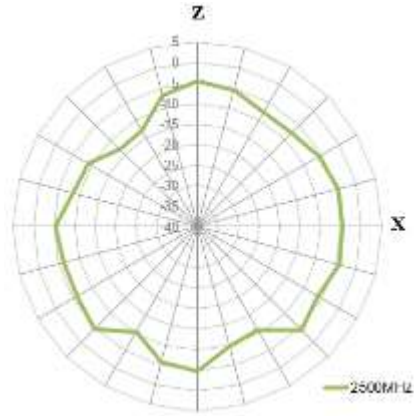
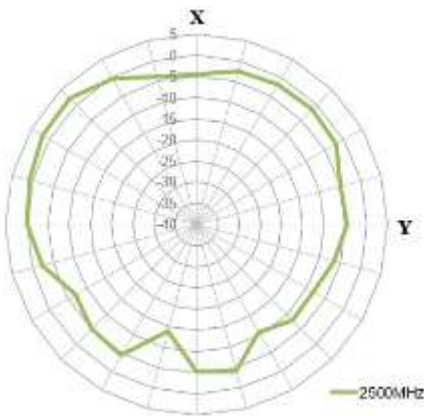

2600MHz

Azimuth = 0.0
Elevation = 0.0
Roll = -45.0

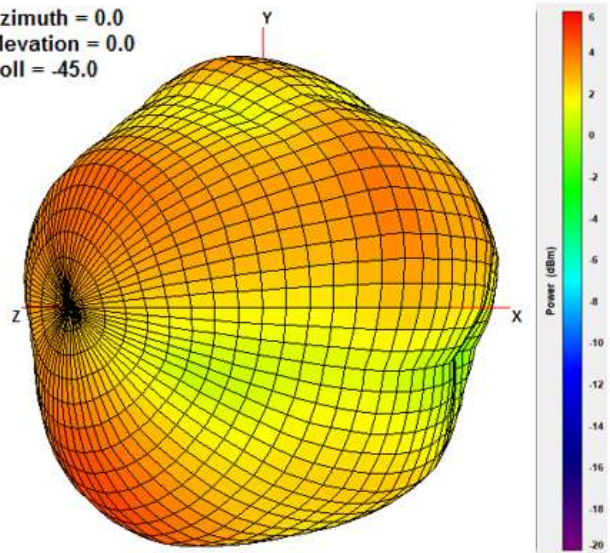

XY Plane

XZ Plane

YZ Plane

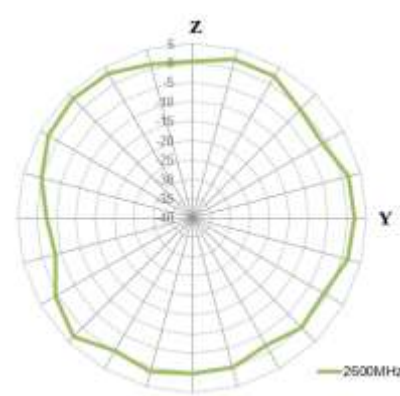
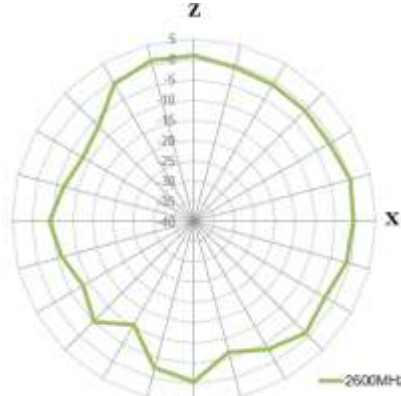
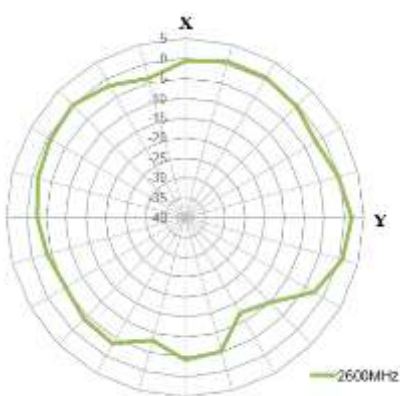

2700MHz

Azimuth = 0.0
Elevation = 0.0
Roll = -45.0

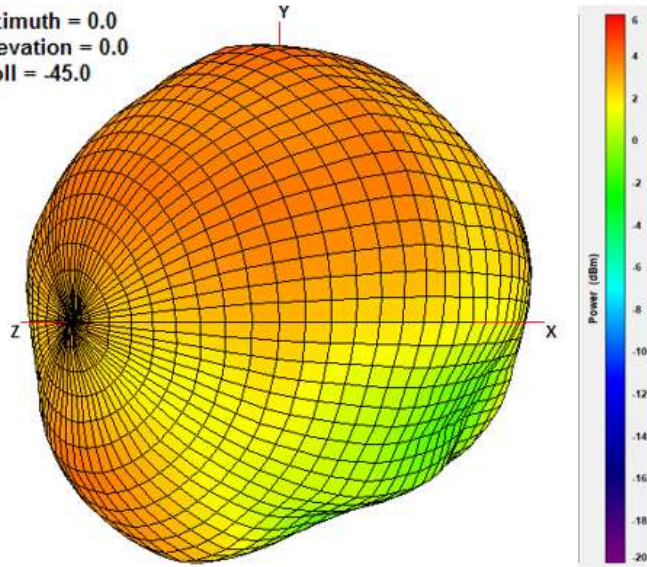

XY Plane

XZ Plane

YZ Plane

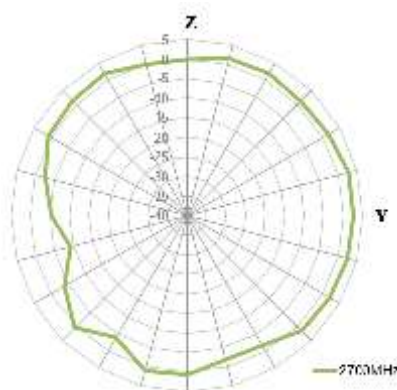
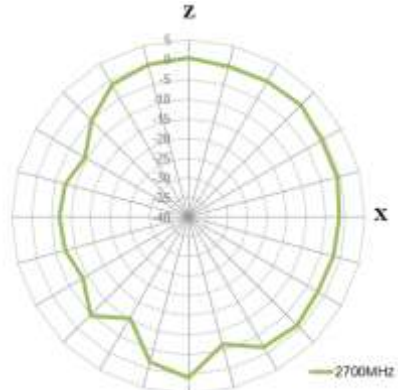
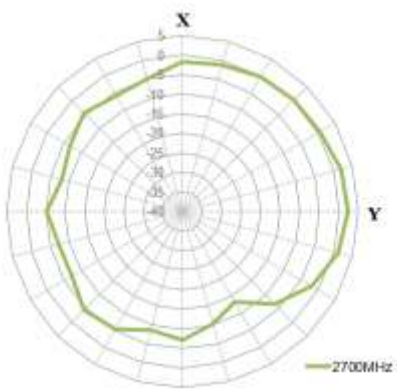

5000MHz

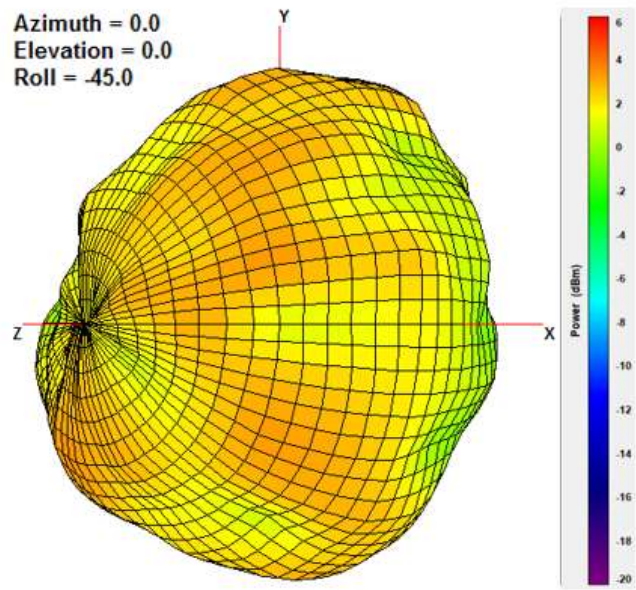

XY Plane

XZ Plane

YZ Plane

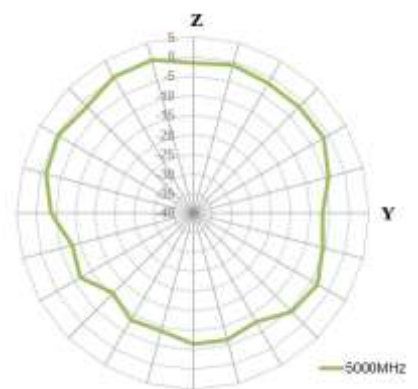
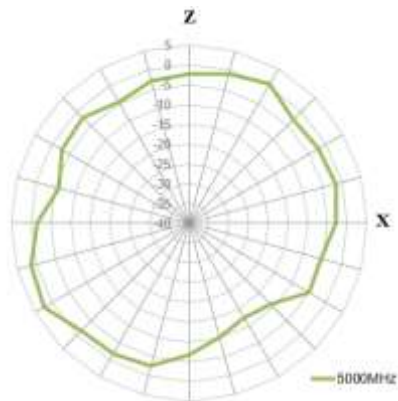
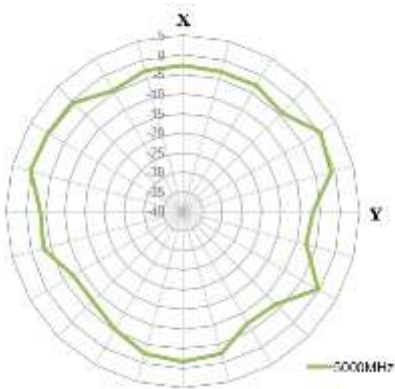

5150MHz

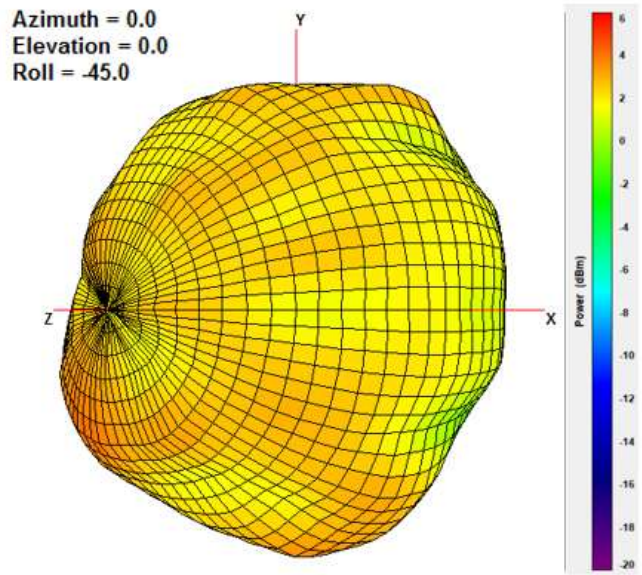

XY Plane

XZ Plane

YZ Plane

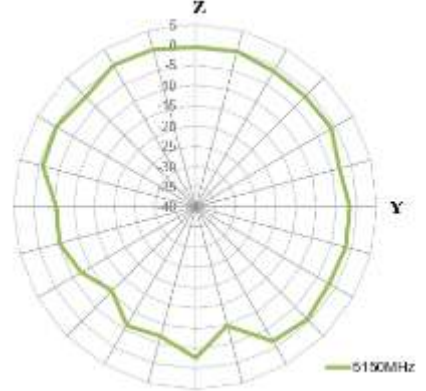
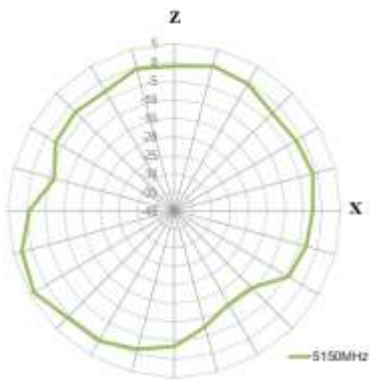
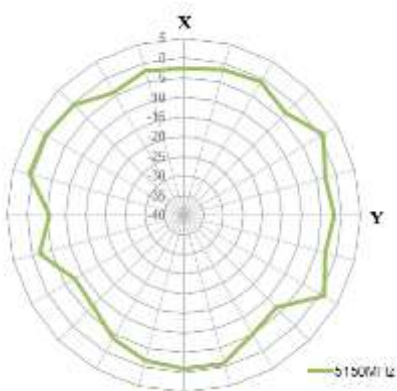

5550MHz

Azimuth = 0.0
Elevation = 0.0
Roll = -45.0

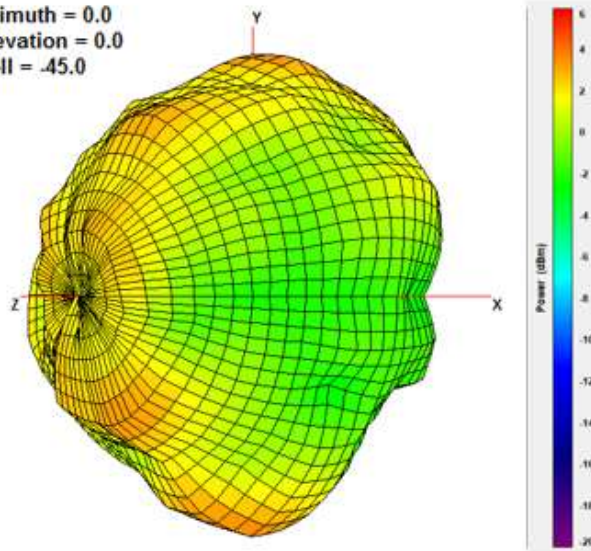

XY Plane

XZ Plane

YZ Plane

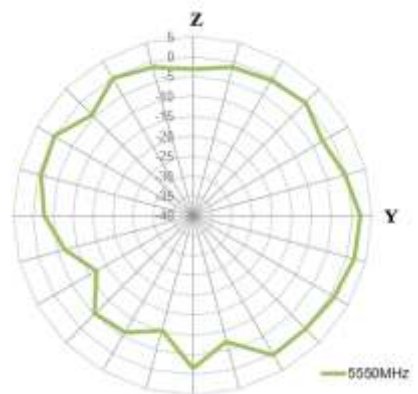
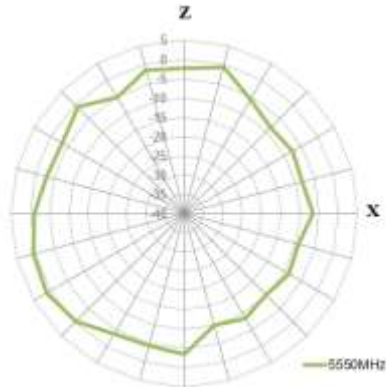
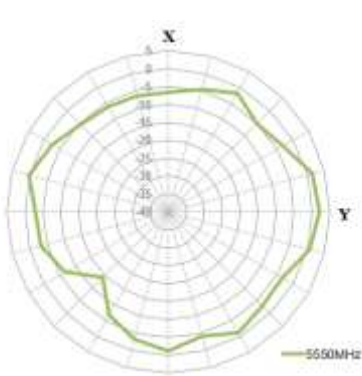

5850MHz

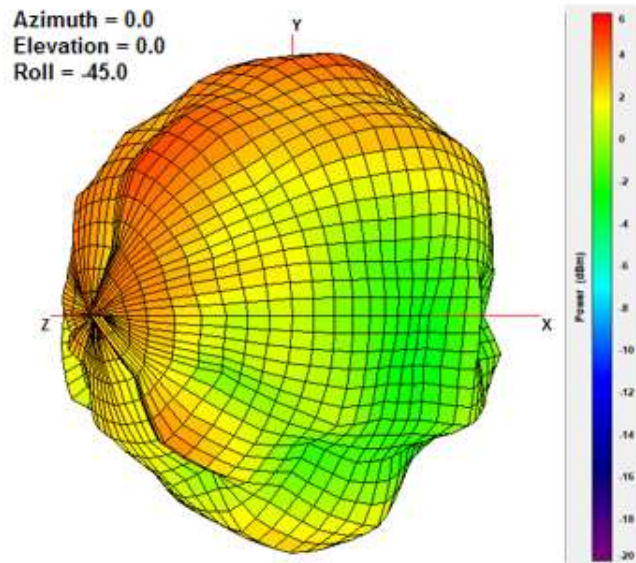

XY Plane

XZ Plane

YZ Plane

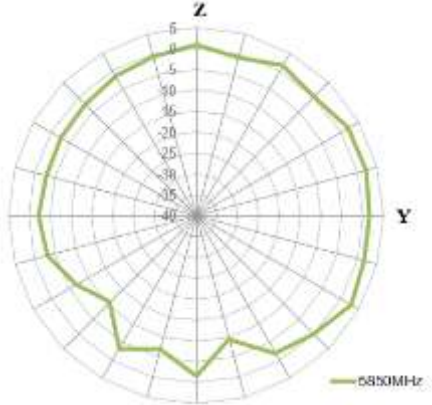
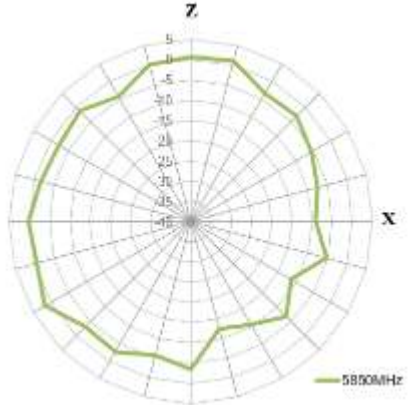
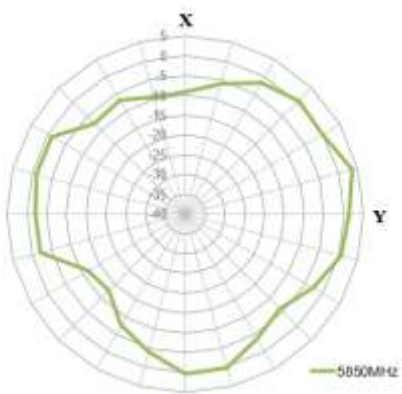

5. Mechanical Drawing (Units: mm)

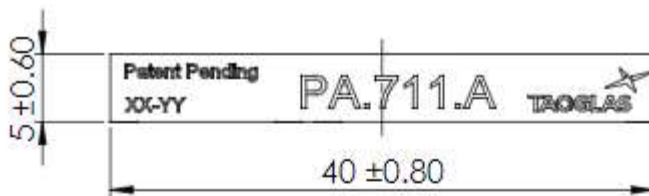

TOP VIEW

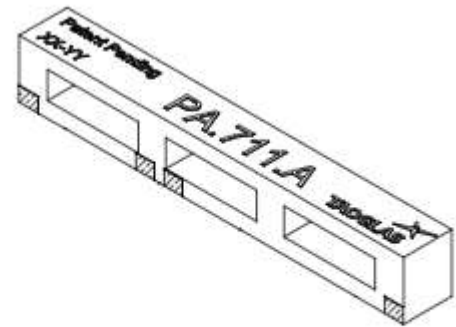

ISOMETRIC VIEW

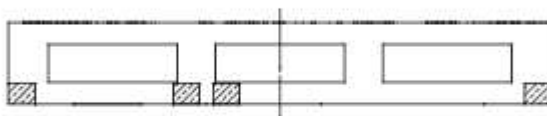

FRONT VIEW

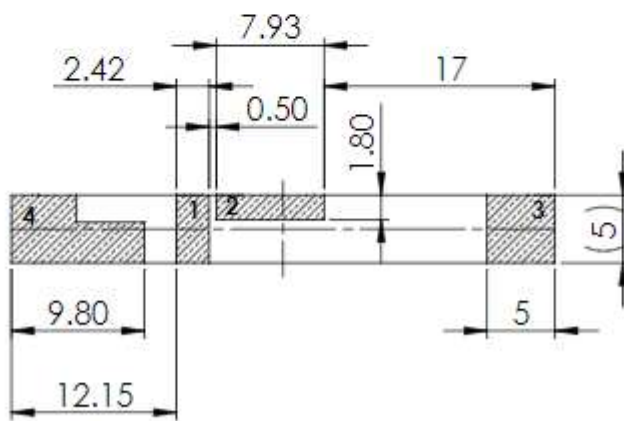

BOTTOM VIEW

6. Antenna Intergration Guide

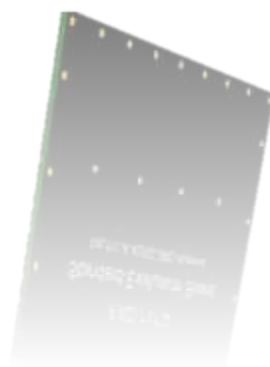

6.1 Schematic Symbol and Pin Definition

The circuit symbol for the antenna is shown below. The antenna has 4 pins with only two pins (Pin 1 and Pin 2) as functional. Pins 3 and 4 are for mechanical strength.

Pin	Description
1	RF Feed
2	Ground
3, 4	Mechanical, Not Connected

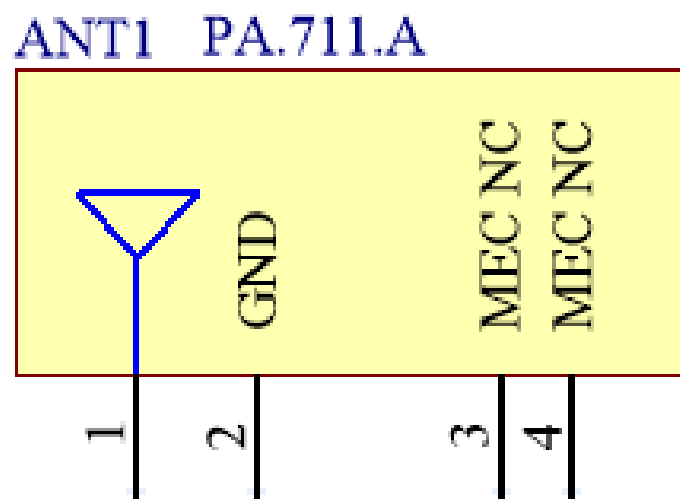

6.2 Antenna Integration

Whatever the size of the PCB, the antenna should ideally be placed on the PCB's shortest side, to take advantage of the ground plane. Optimized matching components can be placed as shown.

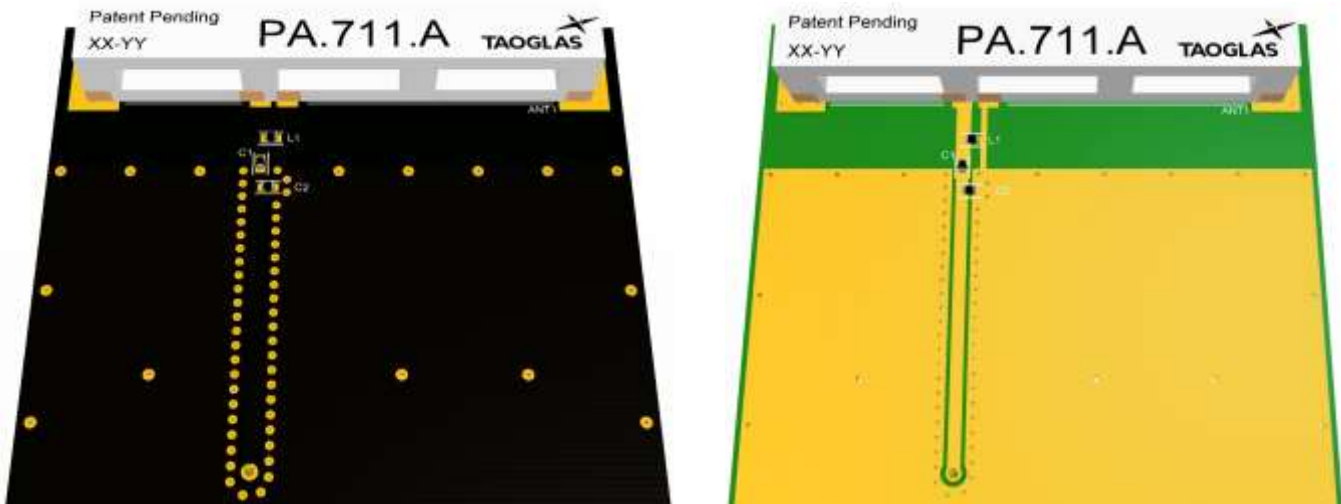

6.3 PCB Layout

The footprint and clearance on the PCB must meet the antenna specification. An example of the PCB layout shows the antenna footprint with clearance. Note the placement of the optimized components. L1 is positioned outside the ground plane and R2 is sitting across the ground plane and the copper clearance area. C1 is optional as a component but it is recommended to include these pads in case they are needed.

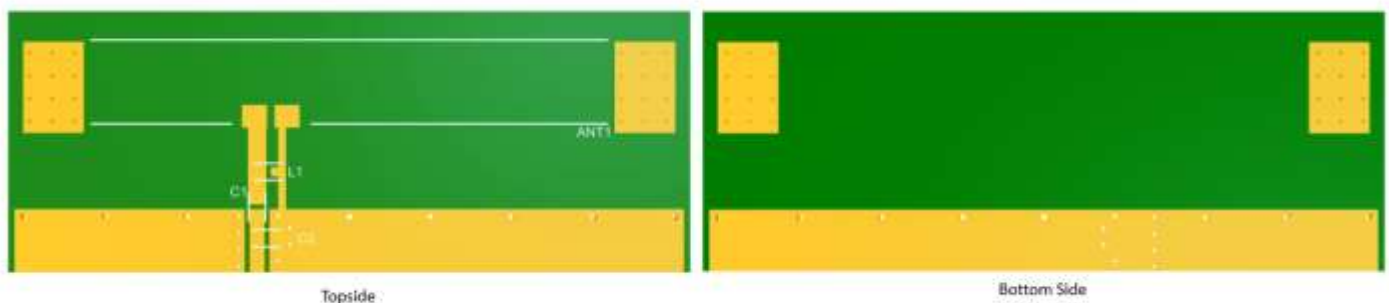

6.4 PCB Keep Out

Below shows the antenna footprint and clearance through ALL layers on the PCB. Only the antenna pads and connections to feed and GND are present within this clearance area (marked RED). The clearance area extends to 5mm from the antenna mechanical pads to the ground area. This clearance area includes the bottom side and ALL internal layers on the PCB.



Topside

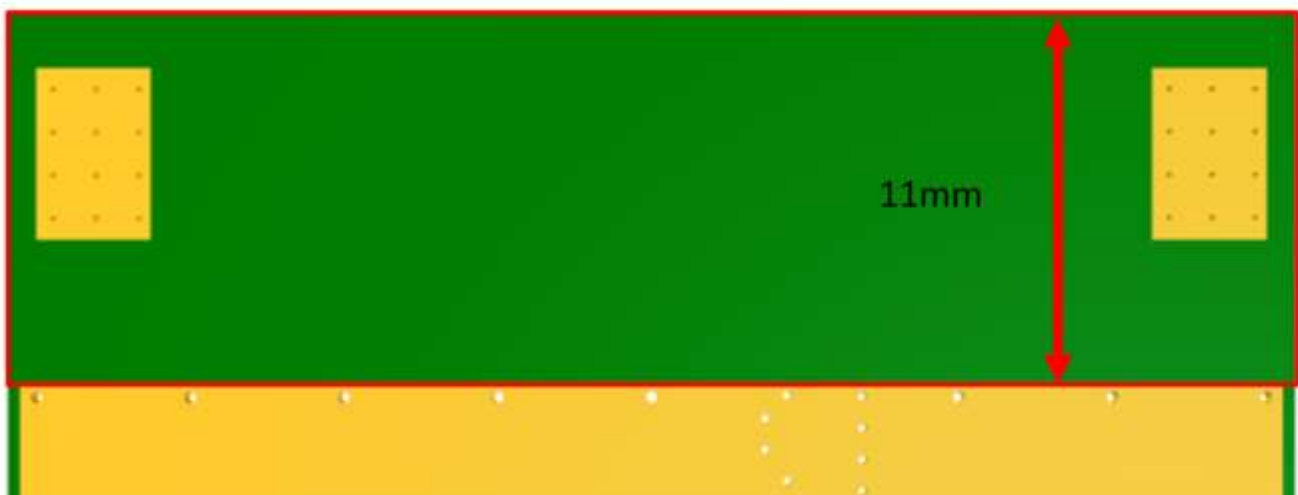

Bottom side

6.5 Evaluation Board

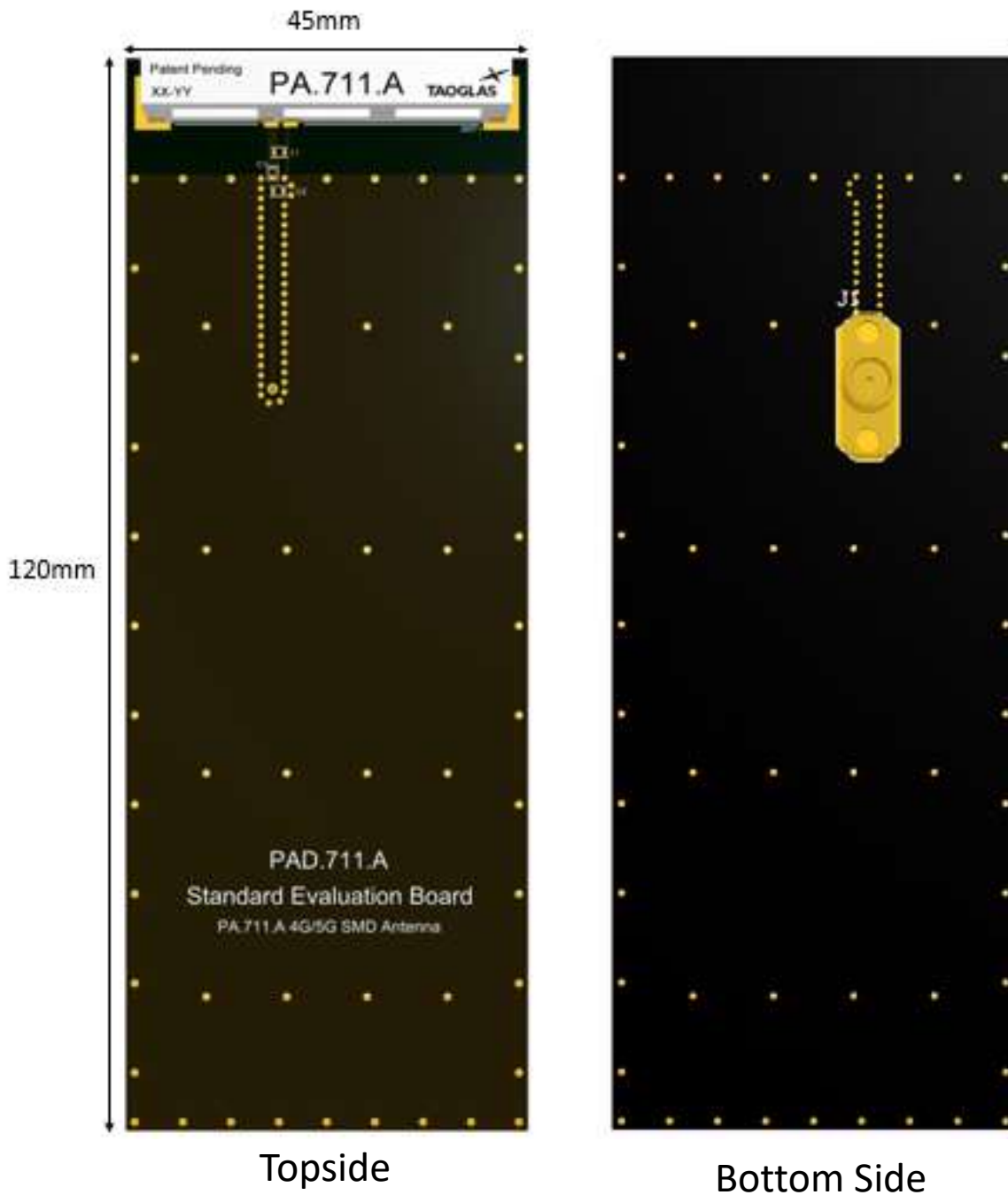

6.6 Evaluation Board Ground Plane Length

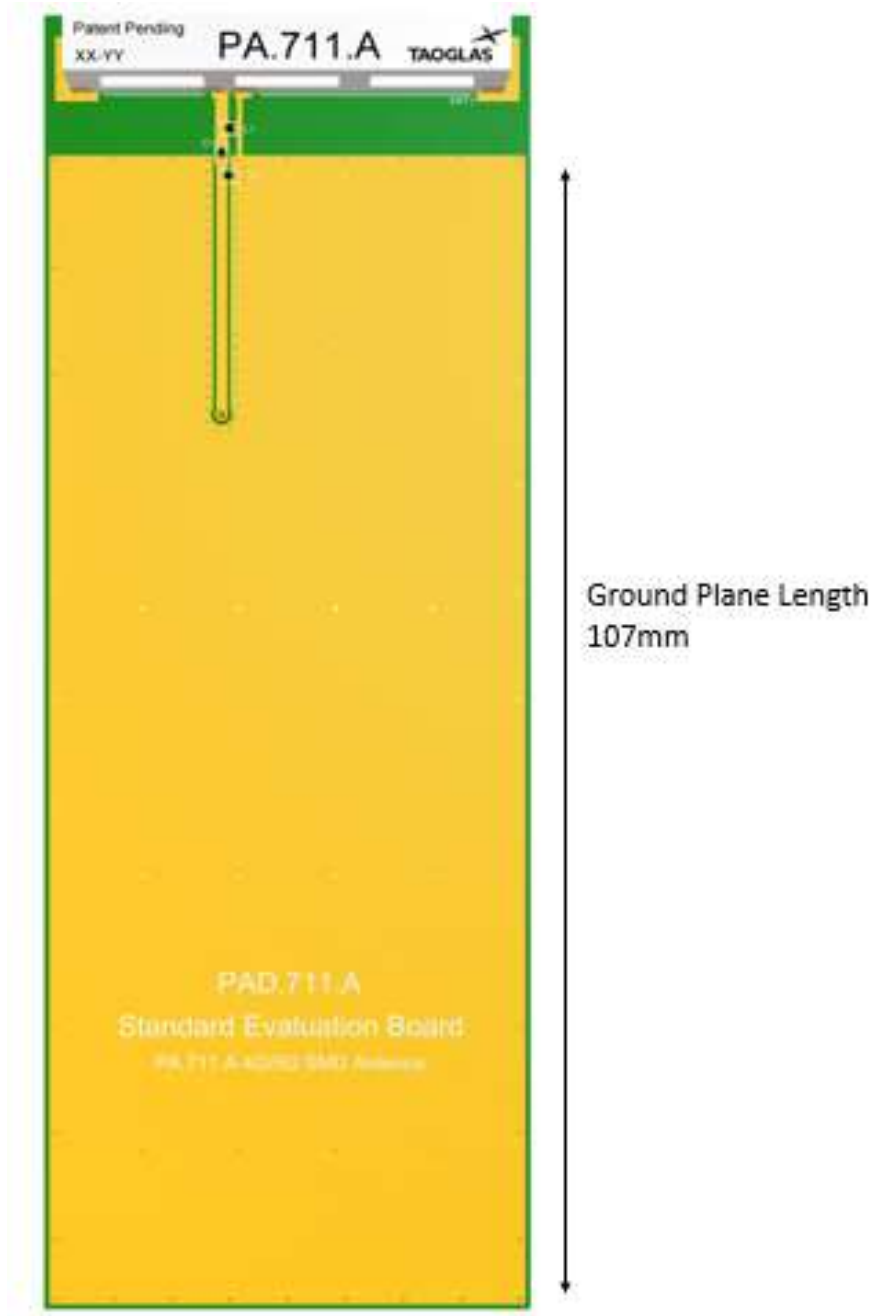

6.7 Evaluati on Board Matching Circuit

A matching component (L1) in parallel with the PA.710.A is required for the antenna to have optimal performance on the evaluation board, located outside of the ground plane in the space specified in the above images. Additional matching components may be necessary for your device, so we recommend incorporating extra component footprints, forming a “pi” network, between the cellular module and the edge of the ground plane.

Designator	Type	Value
L1	Inductor	5.6nH
C1	Capacitor	4.3pF
C2	Capacitor	Not Fitted

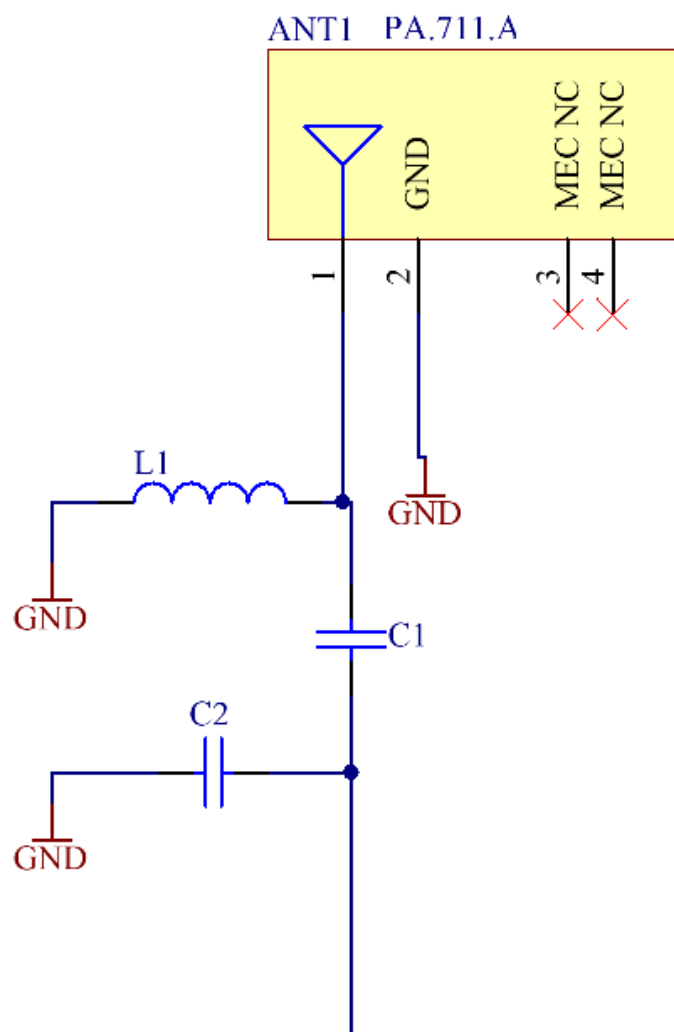

6.8 PCB Footprint Information

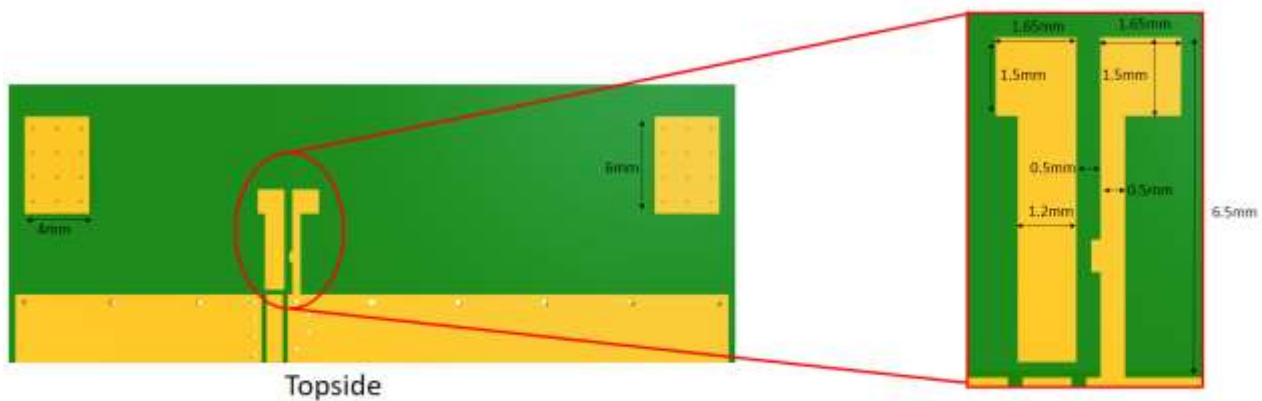

6.9 Vias in Mechanical Pads

Vias are placed in the “no-connect” pads to provide mechanical strength for the pad. These vias are 0.2mm and plated. These vias should be filled with a non-conductive material. Please ensure that the topside surface finish is flat on these pads and the RF Feed and Ground Pad. Vias are covered with soldermask (tenting) on the bottom side.



6.10 Footprint

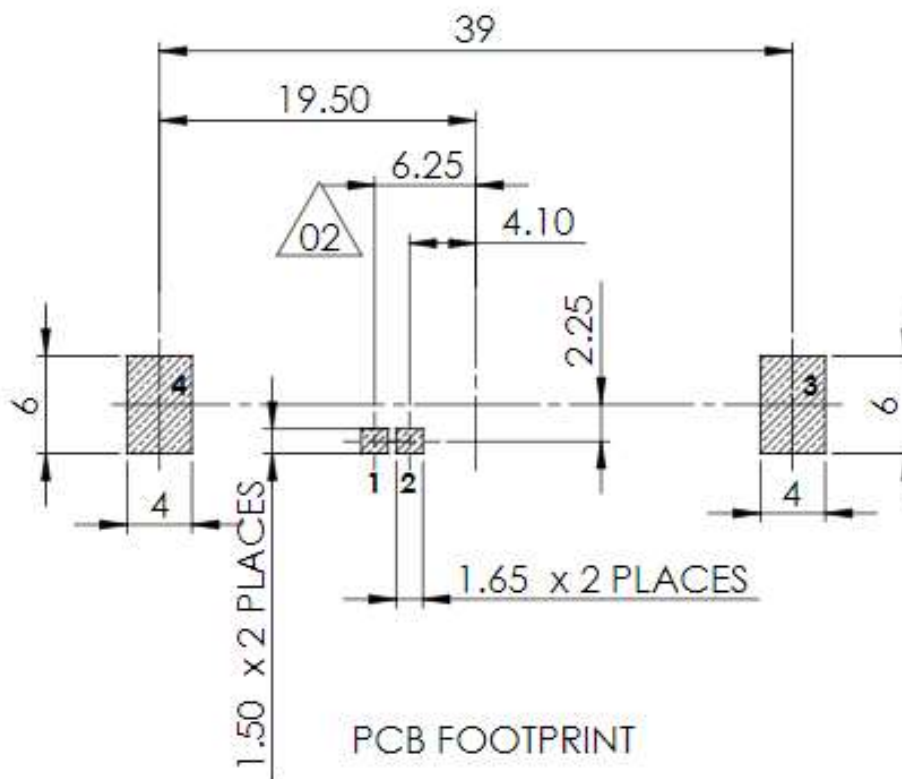

<u>PIN:</u>	<u>DESCRIPTION:</u>
1	FEED (50 OHM)
2	GND
3,4	NC

7. Packaging

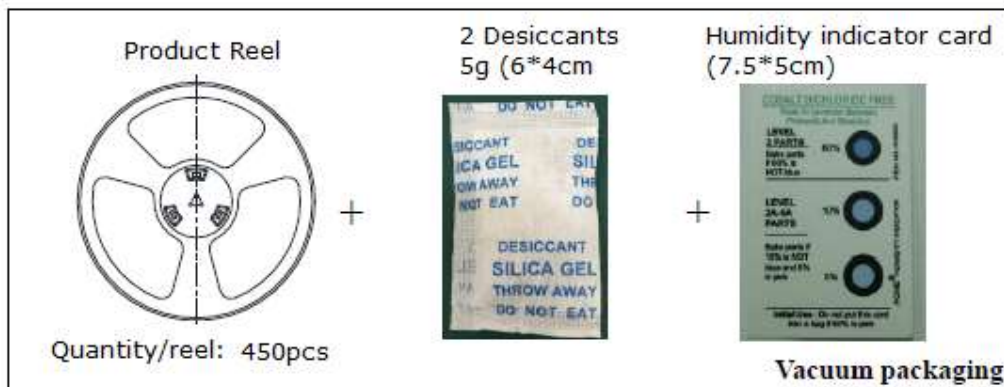

450 pc PA.711.A
1 reel in small inner box
Dimensions - 350*350*70
Weight - 2.4Kg

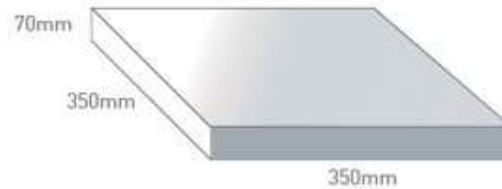

3 boxes / 1350 pcs in one carton
Carton Dimensions - 370*360*275
Weight -7.9Kg

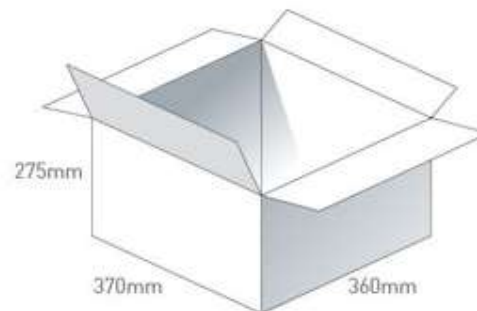

Pallet Dimensions 1110mm*720mm*1100mm
24 Cartons per Pallet
6 Cartons per layer
4 Layers

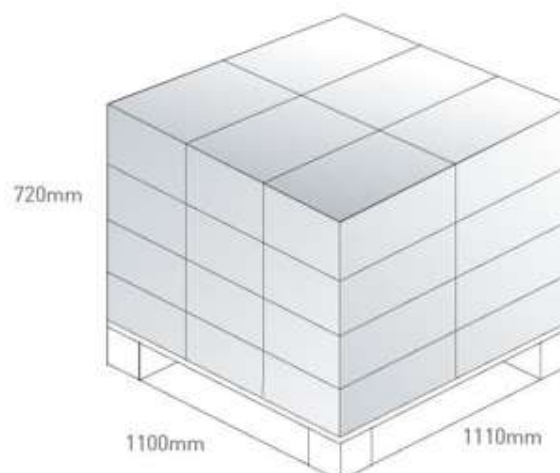

Changelog for the datasheet

SPE-14-8-063 - PA.711.A

Revision: F (Current Version)

Date:	2022-01-05
Changes:	Amended footprint drawing
Changes Made by:	Gary West

Previous Revisions

Revision: E

Date:	2021-02-17
Changes:	Update datasheet template and added antenna integration guide.
Changes Made by:	Gary West

Revision: D

Date:	2020-06-11
Changes:	Replaced Row Humidity Non-condensing 65°C 95% RH with Moisture Sensitivity Level 3 in Specification Table Updated Datasheet to current format
Changes Made by:	Dan Cantwell

Revision: C

Date:	2016-06-01
Changes:	Updated spec to 6GHz
Changes Made by:	Aine Doyle

Revision: B

Date:	2015-01-20
Changes:	Removed PAD.71Y
Changes Made by:	Aine Doyle

Revision: A (Original First Release)

Date:	2014-08-20
Notes:	First Release
Author:	Yaqiang Liu



www.taoglas.com