

Rating	Value	Units
Input Power Level	10	dBm
DC Voltage	12	VDC
Storage Temperature	-40 to +125	°C
Operable Temperature Range	-40 to +105	°C
Soldering Temperature (10 seconds/5 cycles Max..)	260	°C

Primary Electrical Connections

Pin	Connection
1	Input Return
2	Input
3	Ground
4	Output Return
5	Output
6	Ground

Primary Matching Circuit to 50 Ω

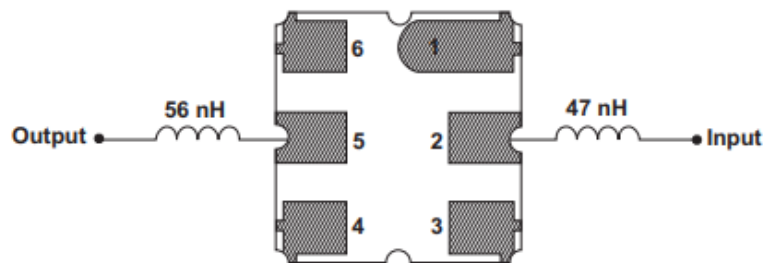

Alternate Electrical Connections

Pin	Connection
1	Input
2	Input Return
3	Ground
4	Output
5	Output Return
6	Ground

Alternate Matching Circuit to 50 Ω



Case Dimensions

Dimension	mm			Inches		
	Min	Nom	Max	Min	Nom	Max
A	2.87	3.0	3.13	0.113	0.118	0.123
B	2.87	3.0	3.13	0.113	0.118	0.123
C	1.12	1.25	1.38	0.044	0.049	0.054
D	0.77	0.90	1.03	0.030	0.035	0.040
E	2.67	2.80	2.93	0.105	0.110	0.115
F	1.47	1.6	1.73	0.058	0.063	0.068
G	0.72	0.85	0.98	0.028	0.033	0.038
H	1.37	1.5	1.63	0.054	0.059	0.064
I	0.47	0.60	0.73	0.019	0.024	0.029
J	1.17	1.30	1.43	0.046	0.051	0.056

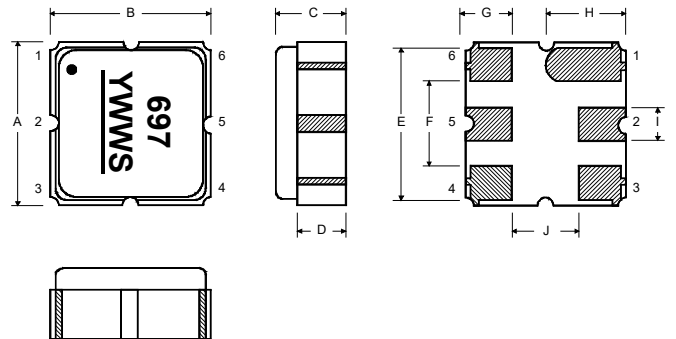

11 Jan 2008 06:46:14

CH1 S11 1 UFS 1: 51.947 Ω 3.0938 Ω 1.1347 nH 433.920000 MHz

hp
RF3404E DEMO
USING 401-1564-001 PCB.

Cor

PRm

Full

↑

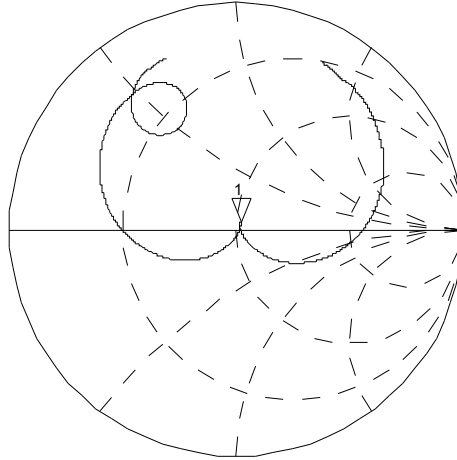

CH2 S22 1 UFS 1: 46.564 Ω 5.0996 Ω 1.8705 nH 433.920000 MHz

Cor

Full

PRm

↑

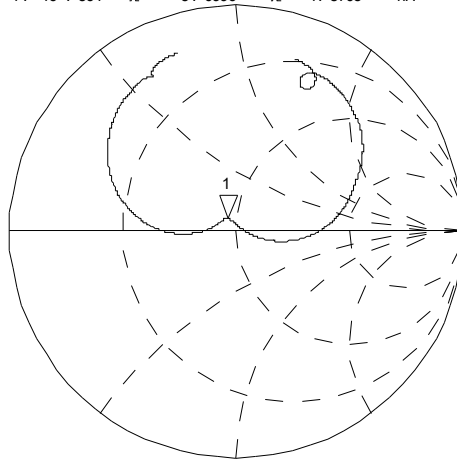

CENTER 433.920000 MHz

SPAN 2.000000 MHz

11 Jan 2008 10:22:38

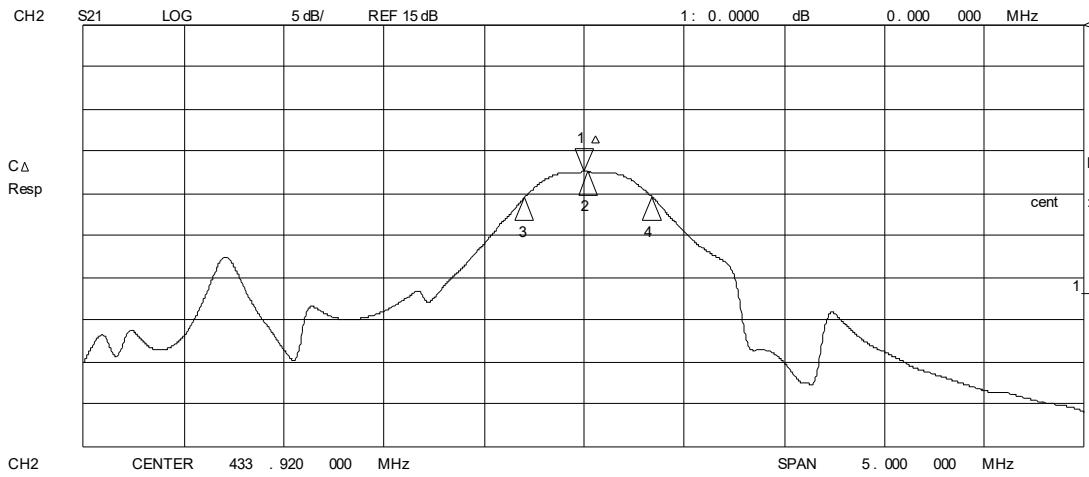
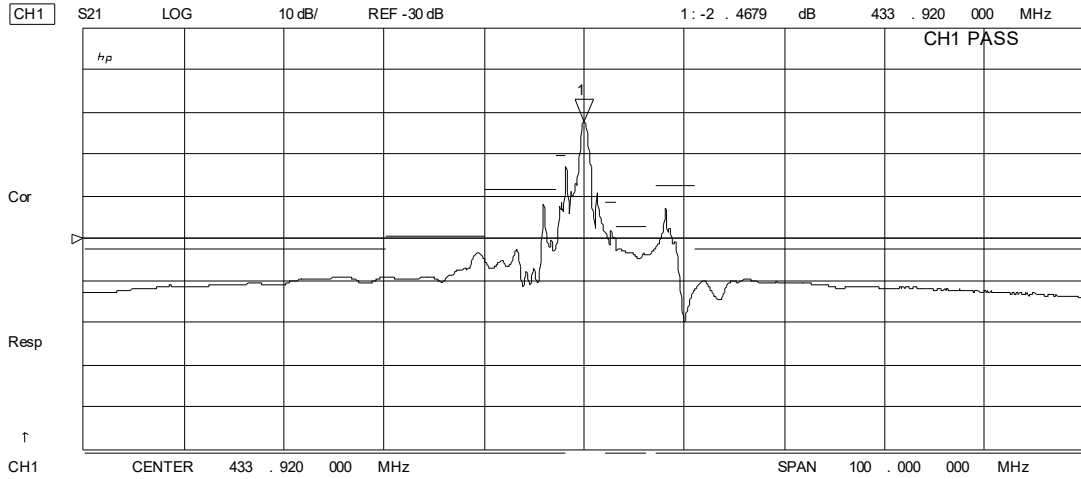

Recommended Reflow Profile

1. Preheating shall be fixed at 150~180°C for 60~90 seconds.
2. Ascending time to preheating temperature 150°C shall be 30 seconds min.
3. Heating shall be fixed at 220°C for 50~80 seconds and at 260°C +0/-5°C peak (10 seconds).
4. Time: 5 times maximum.

