

NOTES:

1. MATERIALS AND FINISHES:
 - BODY - BRASS, GOLD PLATING (.000003 MIN THICK)
 - INSULATOR - PTFE, NATURAL
 - CONTACT PIN - BRASS, GOLD PLATING (.000030 MIN THICK)
 - RETAINER RING - BERYLLIUM COPPER, GOLD PLATING (.000003 MIN THICK)
 - COVER - BRASS, GOLD PLATING (.000003 MIN THICK)
 - FERRULE - BRASS, NICKEL PLATING (.000100 MIN THICK)
2. ELECTRICAL:
 - A. IMPEDANCE: 50 OHM
 - B. FREQUENCY RANGE: DC 0-6 GHz
 - C. VSWR(RETURN LOSS): 1.4 (15.56 dB), MAX.
 - D. DIELECTRIC WITHSTANDING VOLTAGE: 500 VRMS, MIN.
3. MECHANICAL:
 - A. DURABILITY: 500 CYCLES MIN.
 - B. TEMPERATURE RANGE: -65°C to +165°C
4. PACKAGING:
 - A. QUANTITY: SINGLE PACK
 - B. MARKING: BAG TO BE MARKED "AMPHENOL, 908-43001, AND DATE CODE"
5. CABLE ASSEMBLY INSTRUCTIONS
 - A. TRIM CABLE TO EXPOSE BRAID AS SHOWN
 - B. SLIDE INNER FERRULE OVER BRAID UNTIL BOTTOMING AGAINST CABLE JACKET.
 - C. DRESS BRAID AND FOLD BACK COMPLETELY OVER INNER FERRULE WITHOUT DAMAGING BRAID, EXPOSING DIELECTRIC
 - D. TRIM DIELECTRIC .055 [1.4] FROM END OF CABLE, EXPOSING CENTER CONDUCTOR
 - E. INSERT CABLE WITH INNER FERRULE INTO BODY UNTIL BOTTOMING
 - F. CRIMP BODY OVER INNER FERRULE USING .105 HEX
 - G. SOLDER CABLE CENTER CONDUCTOR TO CONNECTOR CENTER CONTACT
 - H. INSERT DIELECTRIC DISC INTO REAR CAVITY OF CONNECTOR
 - I. PRESS CAP INTO REAR CAVITY OF CONNECTOR UNTIL FLUSH WITH REAR SURFACE OF CONNECTOR BODY
6. CRIMP FERRULE = HEX CRIMP SIZE .105" CONTACT PIN TO SOLDER.

THIRD ANGLE PROJ.

REVISIONS				
REV	DESCRIPTION	DATE	ECO	APPR
A	RELEASE TO MFG.	12-Oct-04	44809	SH
B	BODY AND SPRING RING WERE CHANGED	28-Oct-11	48847	SH

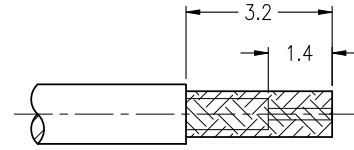

RECOMMENDED STRIPPING DIM'S

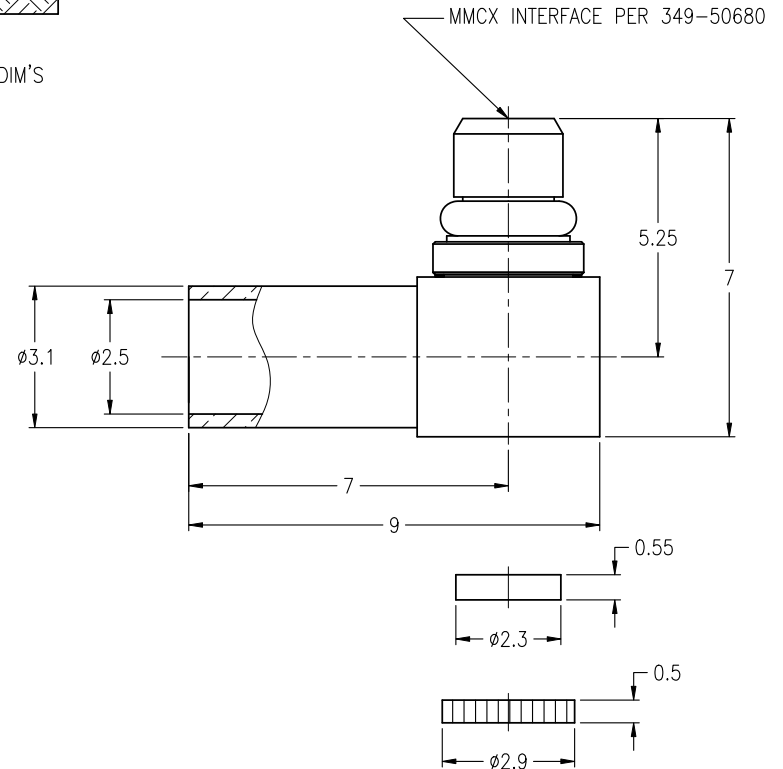
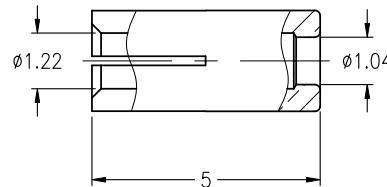

CUSTOMER OUTLINE DRAWING
ALL OTHER SHEETS ARE FOR INTERNAL USE ONLY

UNLESS OTHERWISE SPECIFIED, DIMENSIONS ARE IN METRIC AND TOLERANCES ARE: <0.5mm ±0.05mm 0.5 - 6mm ±0.1mm 6 - 30mm ±0.2mm 30 - 120mm ±0.3mm ANGLES ±1°	MATERIAL	DRAWN T.DENG DATE 26-Oct-11	TITLE		Amphenol RF Danbury CT USA, Tainan Taiwan, Shenzhen China www.amphenolrf.com	
	REFERENCE	ENGINEER S.LI DATE 26-Oct-11	MMCX R/A CRIMP PLUG (FOR Ø1.13 CABLE)		DRAWING NO. MMCX1112A3-001-N/3GT30G-50	
NOTICE - These drawings, specifications, or other data (1) are, and remain the property of Amphenol Corp. (2) must be returned upon request; and (3) are confidential and not to be disclosed to any person other than those to whom they are given by Amphenol Corp. The furnishing of these drawings, specifications, or other data by Amphenol Corp., or to any other person to anyone for any purpose is not to be regarded by implication or otherwise in any manner licensing, granting rights or permitting such holder or any other person to manufacture, use or sell any product, process or design, patented or otherwise, that may in any way be related to or disclosed by said drawings, specifications, or other data.	FINISH	APPROVED S.HSIEH DATE 26-Oct-11	SCALE: 6/1	SHEET 2 OF 2	ITEM NO. 091112AAEA1NP5F	
		F:\DWG\MCMX\1112A3\001\50\N3GT30G-BSZ	CAD FILE	DWG SIZE B	REV B	PART NO. 908-43001