

CGHV14250

250 W, DC - 1.6 GHz, GaN HEMT for L-Band Radar Systems

Description

Cree's CGHV14250 is a gallium nitride (GaN) high electron mobility transistor (HEMT) designed specifically with high efficiency, high gain and wide bandwidth capabilities, which makes the CGHV14250 ideal for DC - 1.6 GHz L-Band radar amplifier applications. The transistor could be utilized for band specific applications ranging from 0.9 through 1.8 GHz. The package options are ceramic/metal flange and pill package.

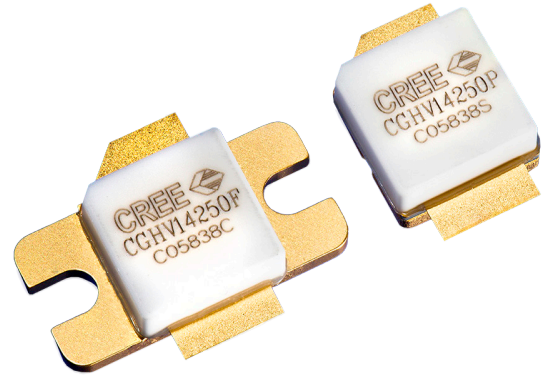

Package Types: 440162, 440161
PNs: CGHV14250F, CGHV14250P

Typical Performance Over 1.2 - 1.4 GHz (TC = 25 °C) of Demonstration Amplifier

Parameter	1.2 GHz	1.25 GHz	1.3 GHz	1.35 GHz	1.4 GHz	Units
Output Power	365	365	350	310	330	W
Gain	18.6	18.6	18.4	17.9	18.2	dB
Drain Efficiency	80	80	77	74	76	%

Note: Measured in the CGHV14250-AMP amplifier circuit, under 500 μ s pulse width, 10% duty cycle, P_{in} = 37 dBm.

Features

- Reference design amplifier 1.2 - 1.4 GHz Operation
- FET Tuning range UHF through 1800 MHz
- 330 W Typical Output Power
- 18 dB Power Gain
- 77 % Typical Drain Efficiency
- < 0.3 dB Pulsed Amplitude Droop
- Internally pre-matched on input, unmatched output

 Large Signal Models Available for ADS and MWO

RoHS
COMPLIANT

Absolute Maximum Ratings (not simultaneous)

Parameter	Symbol	Rating	Units	Conditions
Drain-Source Voltage	V_{DSS}	150	Volts	25 °C
Gate-to-Source Voltage	V_{GS}	-10, +2	Volts	25 °C
Storage Temperature	T_{STG}	-65, +150	°C	
Operating Junction Temperature	T_J	225	°C	
Maximum Forward Gate Current	I_{GMAX}	42	mA	25 °C
Maximum Drain Current ¹	I_{DMAX}	18	A	25 °C
Soldering Temperature ²	T_S	245	°C	
Screw Torque	τ	40	in-oz	
CW Thermal Resistance, Junction to Case ³	$R_{\theta JC}$	0.95	°C/W	$P_{DISS} = 167 \text{ W}, 65^\circ \text{C}$
Pulsed Thermal Resistance, Junction to Case ³	$R_{\theta JC}$	0.57	°C/W	$P_{DISS} = 167 \text{ W}, 500 \mu\text{sec}, 10\%, 85^\circ \text{C}$
Pulsed Thermal Resistance, Junction to Case ⁴	$R_{\theta JC}$	0.63	°C/W	$P_{DISS} = 167 \text{ W}, 500 \mu\text{sec}, 10\%, 85^\circ \text{C}$
Case Operating Temperature ⁵	T_C	-40, +130	°C	$P_{DISS} = 167 \text{ W}, 500 \mu\text{sec}, 10\%$

Notes:

¹ Current limit for long term, reliable operation² Refer to the Application Note on soldering at wolfspeed.com/rf/document-library³ Measured for the CGHV14250P⁴ Measured for the CGHV14250F⁵ See also, the Power Dissipation De-rating Curve on Page 5**Electrical Characteristics ($T_c = 25^\circ \text{C}$)**

Characteristics	Symbol	Min.	Typ.	Max.	Units	Conditions
DC Characteristics¹						
Gate Threshold Voltage	$V_{GS(th)}$	-3.8	-3.0	-2.3	V_{DC}	$V_{DS} = 10 \text{ V}, I_D = 41.8 \text{ mA}$
Gate Quiescent Voltage	$V_{GS(Q)}$	-	-2.7	-	V_{DC}	$V_{DS} = 50 \text{ V}, I_D = 500 \text{ mA}$
Saturated Drain Current ²	I_{DS}	27.2	38.9	-	A	$V_{DS} = 6.0 \text{ V}, V_{GS} = 2.0 \text{ V}$
Drain-Source Breakdown Voltage	V_{BR}	125	-	-	V_{DC}	$V_{GS} = -8 \text{ V}, I_D = 41.8 \text{ mA}$
RF Characteristics³ ($T_c = 25^\circ \text{C}, F_0 = 1.4 \text{ GHz}$ unless otherwise noted)						
Output Power	P_{OUT}	260	300	-	W	$V_{DD} = 50 \text{ V}, I_{DQ} = 500 \text{ mA}, P_{IN} = 37 \text{ dBm}$
Drain Efficiency	D_E	70	77	-	%	$V_{DD} = 50 \text{ V}, I_{DQ} = 500 \text{ mA}, P_{IN} = 37 \text{ dBm}$
Power Gain	G_P	-	17.8	-	dB	$V_{DD} = 50 \text{ V}, I_{DQ} = 500 \text{ mA}, P_{IN} = 37 \text{ dBm}$
Pulsed Amplitude Droop	D	-	-0.3	-	dB	$V_{DD} = 50 \text{ V}, I_{DQ} = 500 \text{ mA}$
Output Mismatch Stress	VSWR	-	5 : 1	-	Y	No damage at all phase angles, $V_{DD} = 50 \text{ V}, I_{DQ} = 500 \text{ mA}, P_{IN} = 37 \text{ dBm}$ Pulsed
Dynamic Characteristics						
Input Capacitance	C_{GS}	-	150	-	pF	$V_{DS} = 50 \text{ V}, V_{gs} = -8 \text{ V}, f = 1 \text{ MHz}$
Output Capacitance	C_{DS}	-	16	-	pF	$V_{DS} = 50 \text{ V}, V_{gs} = -8 \text{ V}, f = 1 \text{ MHz}$
Feedback Capacitance	C_{GD}	-	1.35	-	pF	$V_{DS} = 50 \text{ V}, V_{gs} = -8 \text{ V}, f = 1 \text{ MHz}$

Notes:

¹ Measured on wafer prior to packaging² Scaled from PCM data³ Measured in CGHV14250-AMP. Pulsed Width = 500 μs , Duty Cycle = 10%.



Typical Performance

CGHV14250 Typical Sparameters
 $T_{case} = 25^{\circ}C$, $V_{DD} = 50 V$, $I_{DQ} = 500 mA$

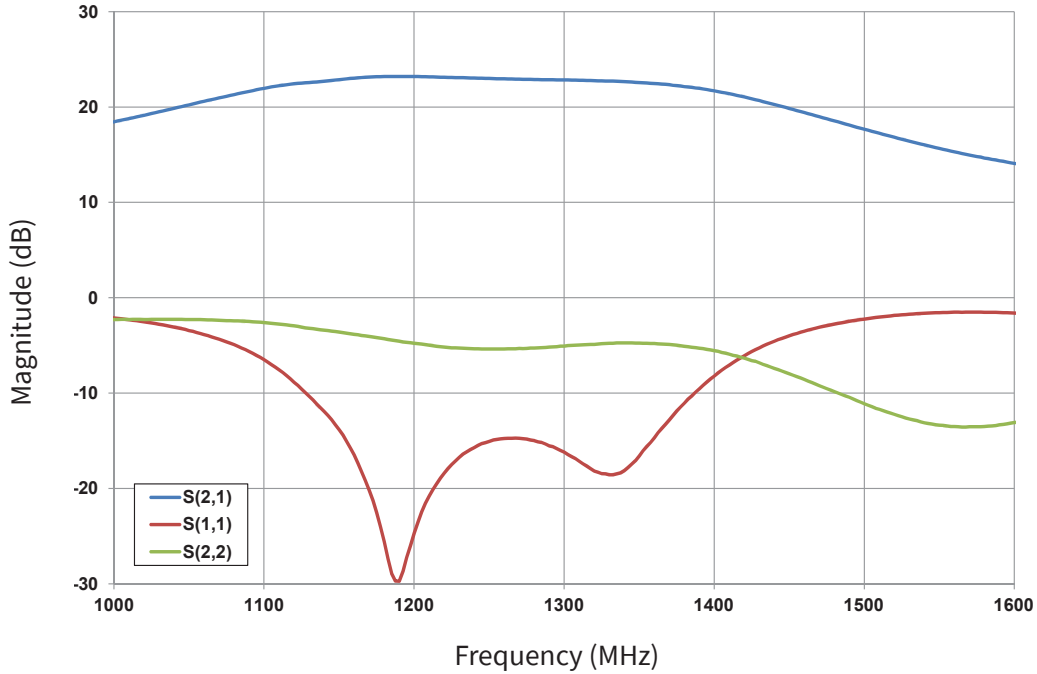

CGHV14250 Typical RF Results
 $V_{DD} = 50 V$, $I_{DQ} = 500 mA$, $P_{IN} = 37 dBm$
 $T_{case} = 25^{\circ}C$, Pulse Width = 500 μs , Duty Cycle = 10%

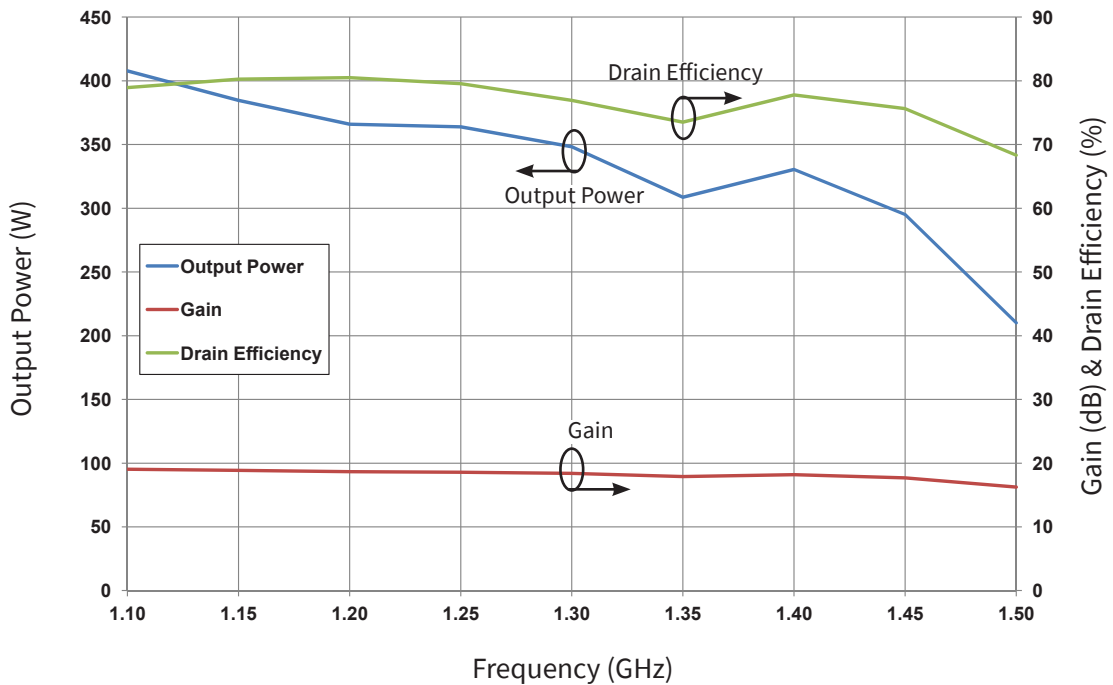

Typical Performance

CGHV14250 Typical RF Results
 $V_{DD} = 50\text{ V}, I_{DQ} = 500\text{ mA}, P_{IN} = 37\text{ dBm}$
 $T_{case} = 85^\circ\text{C}, \text{Pulse Width} = 500\ \mu\text{s}, \text{Duty Cycle} = 10\%$

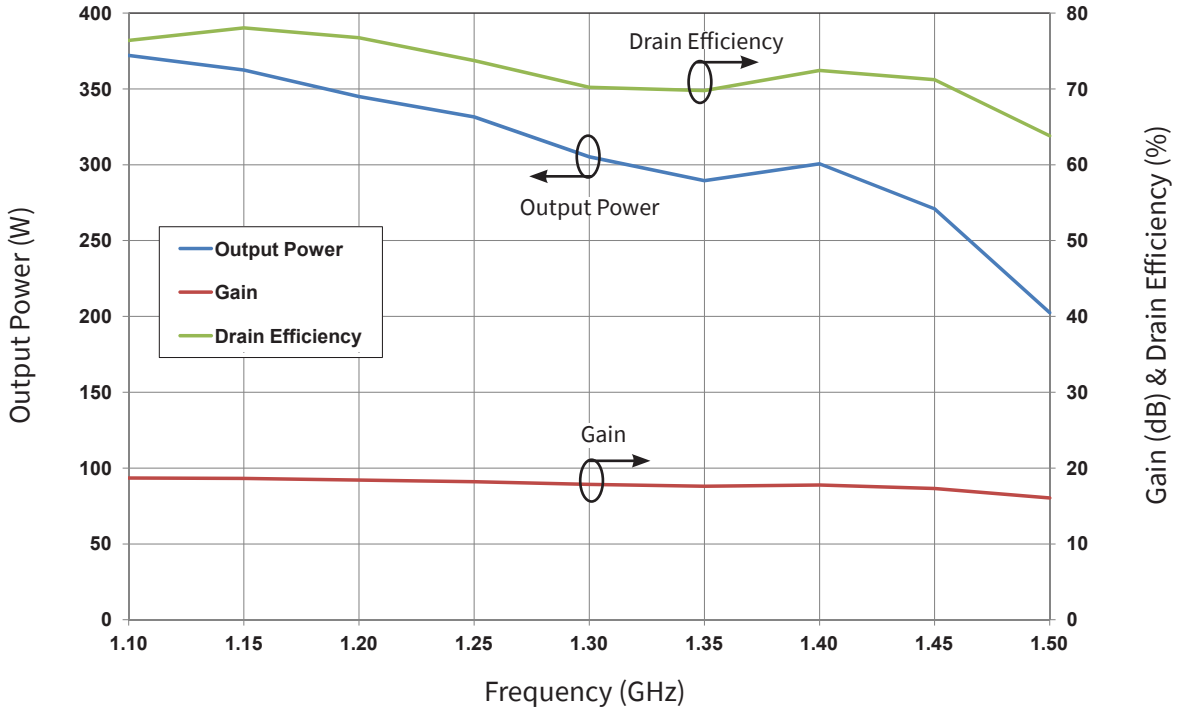

CGHV14250 CW RF Results
 $V_{DD} = 50\text{ V}, I_{DQ} = 500\text{ mA}, P_{IN} = 37\text{ dBm}, T_{case} = 65^\circ\text{C}$

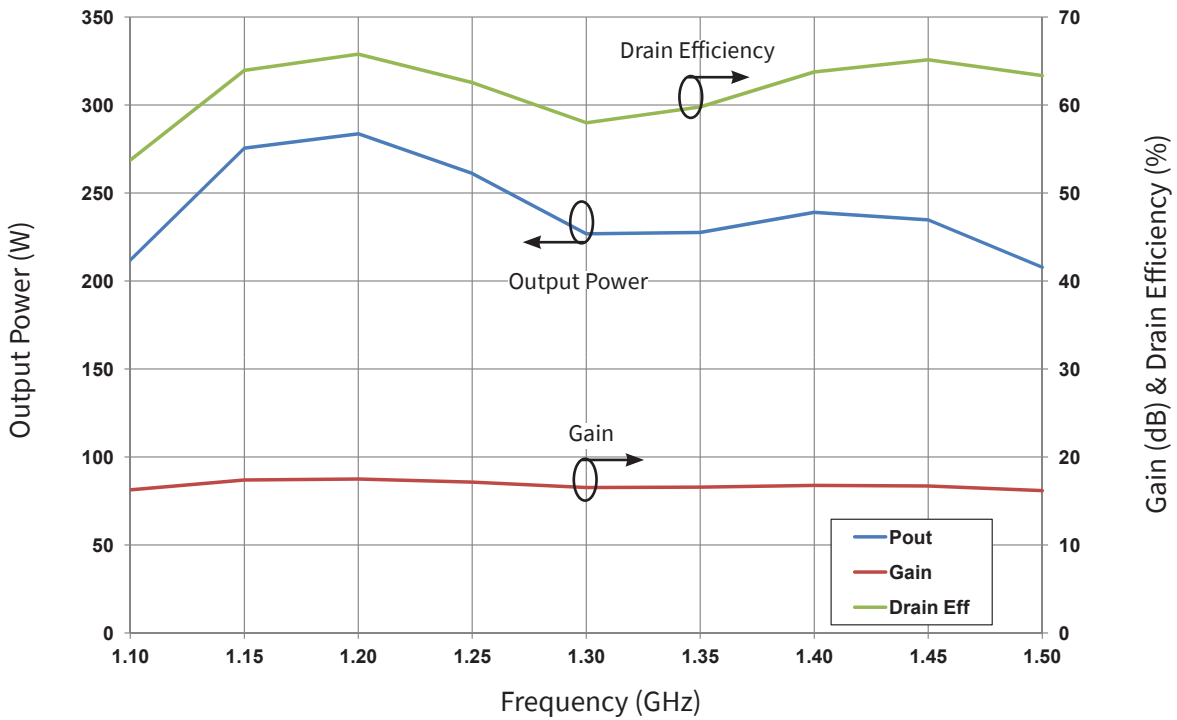

Source and Load Impedances

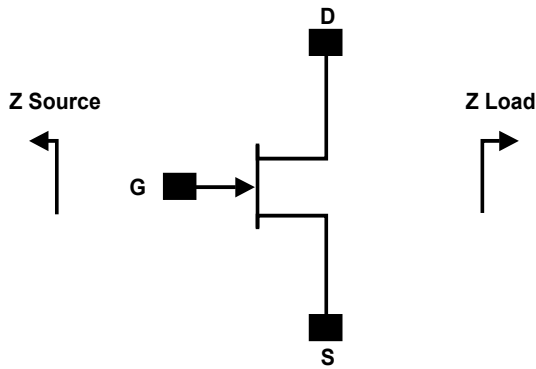

Frequency	Z Source	Z Load
900	0.6 - j0.3	5.3 + j0.1
1000	0.7 - j0.8	4.3 + j0.8
1100	1.3 - j1.1	3.3 + j0.8
1200	1.8 - j1.1	3.0 + j0.4
1300	2.5 - j0.7	2.5 + j0.4
1400	3.4 - j0.7	2.3 + j0.1
1500	1.8 - j0.9	2.3 + j0

- Note 1. $V_{DD} = 50\text{ V}$, $I_{DQ} = 500\text{ mA}$ in the 440162 package
- Note 2. Optimized for power gain, P_{SAT} and Drain Efficiency
- Note 3. When using this device at low frequency, series resistors should be used to maintain amplifier stability

CGHV14250F Power Dissipation De-rating Curve

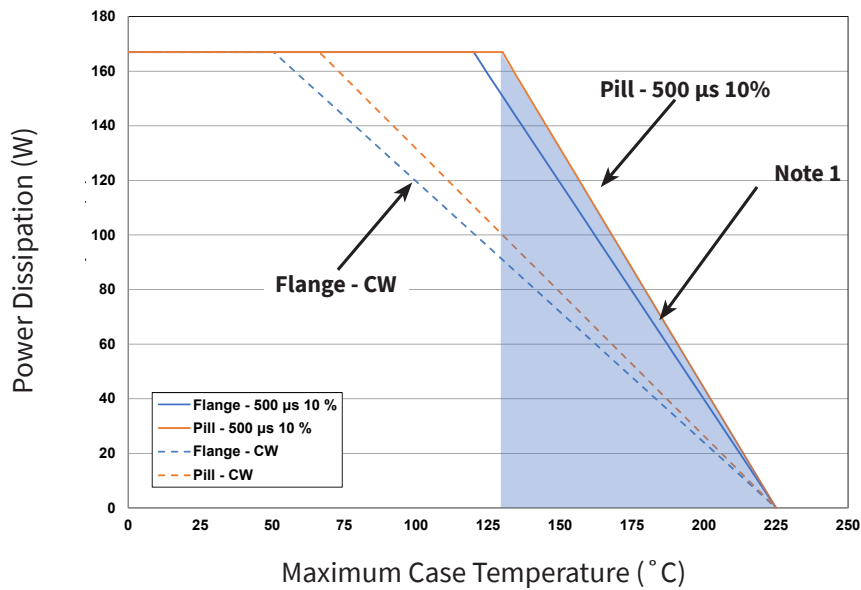

Note 1. Area exceeds Maximum Case Temperature (See Page 2).

CGHV14250-AMP Demonstration Amplifier Circuit Bill of Materials

Designator	Description	Qty
R1	RES, 1/16W, 0603, 1%, 562 OHMS	1
R2	RES, 5.1 OHM, +/-1%, 1/16W, 0603	1
R3	RES, 1/16W, 0603, 1%, 4700 OHMS	1
L1	INDUCTOR, CHIP, 6.8 nH, 0603 SMT	1
C1, C23	CAP, 27pF, +/- 5%, 250V, 0805, ATC 600F	2
C2	CAP, 2.0pF, +/- 0.1pF, 0603, ATC	1
C3, C4	CAP, 0.5pF, +/-0.05pF, 0805, ATC 600F	2
C5,C6	CAP, 1.0pF, +/-0.05 pF, 0805, ATC 600F	2
C7,C8,C9,C10	CAP, 3.0pF, +/-0.1pF, 250V, 0805, ATC 600F	4
C11,C24	CAP, 47pF,+/-5%, 250V, 0805, ATC 600F	2
C12,C25	CAP, 100pF, +/-5%, 250V, 0805, ATC 600F	2
C13,C26	CAP, 33000PF, 0805,100V, X7R	2
C14	CAP 10uF 16V TANTALUM	1
C15,C16,C17,C18	CAP, 3.9pF, +/-0.1pF, 250V, 0805, ATC 600F	4
C19,C20	CAP, 1.2pF, +/-0.05pF, 0805, ATC 600F	2
C27	CAP, 1.0UF, 100V, 10%, X7R, 1210	1
C28	CAP, 3300 UF, +/-20%, 100V, ELECTROLYTIC	1
J1,J2	CONN, SMA, PANEL MOUNT JACK, FL	2
J3	HEADER RT>PLZ .1CEN LK 9POS	1
J4	CONNECTOR ; SMB, Straight, JACK,SMD	1
W1	CABLE ,18 AWG, 4.2	1
-	PCB, RO4350, 0.020 MIL THK, CGHV14250, 1.2-1.4GHZ	1
Q1	CGHV14250	1

CGHV14250-AMP Demonstration Amplifier Circuit

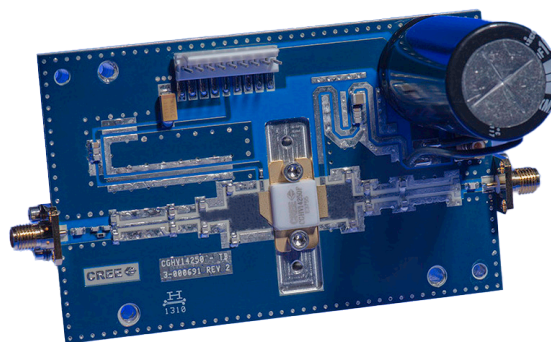

CGHV14250-AMP Demonstration Amplifier Circuit Outline

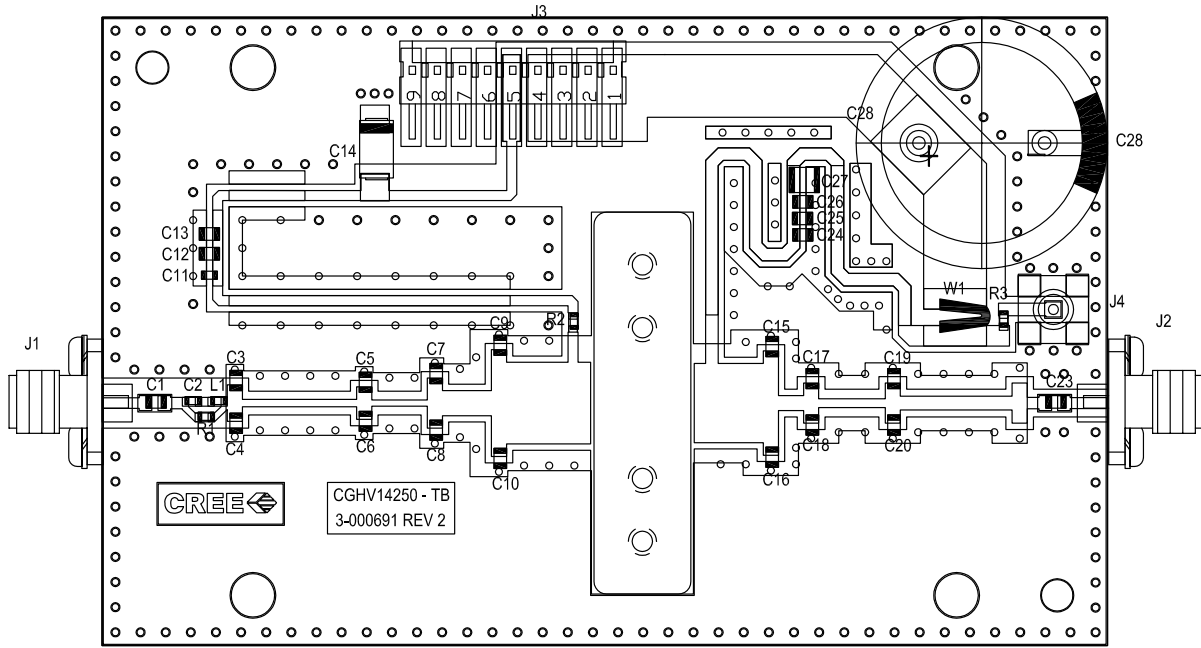

CGHV14250-AMP Demonstration Amplifier Circuit Schematic

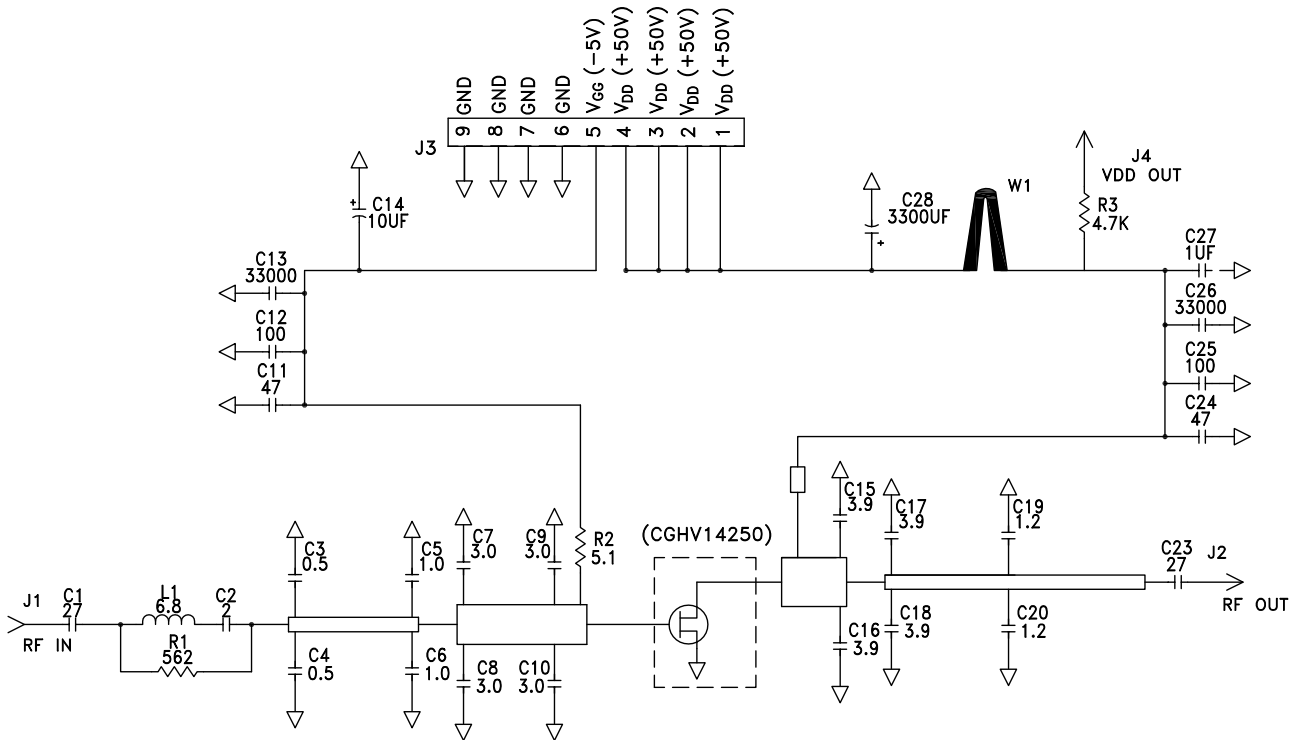



Product Dimensions CGHV14250F (Package Type – 440162)

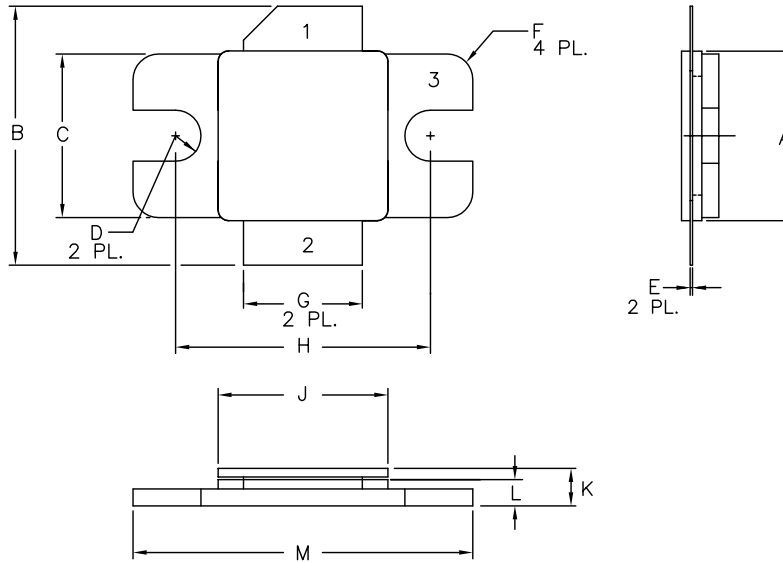

NOTES:

1. DIMENSIONING AND TOLERANCING PER ANSI Y14.5M, 1982.
2. CONTROLLING DIMENSION: INCH.
3. ADHESIVE FROM LID MAY EXTEND A MAXIMUM OF 0.020" BEYOND EDGE OF LID.
4. LID MAY BE MISALIGNED TO THE BODY OF THE PACKAGE BY A MAXIMUM OF 0.008" IN ANY DIRECTION.

DIM	INCHES		MILLIMETERS	
	MIN	MAX	MIN	MAX
A	.395	.405	10.03	10.29
B	.580	.620	14.73	15.75
C	.380	.390	9.65	9.91
D	.055	.065	1.40	1.65
E	.004	.006	0.10	0.15
F	.055	.065	1.40	1.65
G	.275	.285	6.99	7.24
H	.595	.605	15.11	15.37
J	.395	.405	10.03	10.29
K	.129	.149	3.28	3.78
L	.053	.067	1.35	1.70
M	.795	.805	20.19	20.45

- PIN 1. GATE
- PIN 2. DRAIN
- PIN 3. SOURCE

Product Dimensions CGHV14250P (Package Type – 440161)

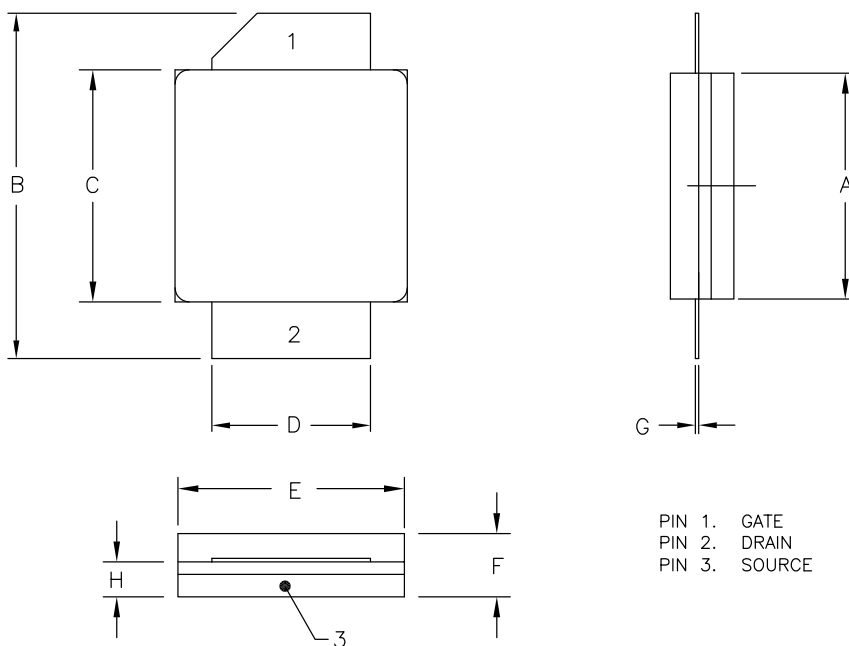

NOTES:

1. DIMENSIONING AND TOLERANCING PER ANSI Y14.5M, 1982.
2. CONTROLLING DIMENSION: INCH.
3. ADHESIVE FROM LID, MAY EXTEND A MAXIMUM OF 0.020" BEYOND EDGE OF LID.
4. LID MAY BE MISALIGNED TO THE BODY OF PACKAGE BY A MAXIMUM OF 0.008" IN ANY DIRECTION.

DIM	INCHES		MILLIMETERS	
	MIN	MAX	MIN	MAX
A	.395	.407	10.03	10.34
B	.594	.634	15.09	16.10
C	.395	.407	10.03	10.34
D	.275	.285	6.99	7.24
E	.395	.407	10.03	10.34
F	.129	.149	3.28	3.78
G	.004	.006	0.10	0.15
H	.057	.067	1.45	1.70

- PIN 1. GATE
- PIN 2. DRAIN
- PIN 3. SOURCE



Part Number System

CGHV14250F

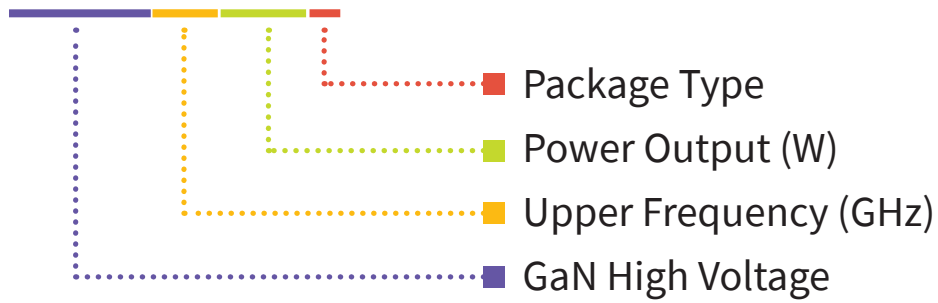

Table 1

Parameter	Value	Units
Upper Frequency ¹	1.4	GHz
Power Output	250	W
Type	F = Flanged P = Package	-

¹ Alpha characters used in frequency code indicate a value greater than 9.9 GHz. See Table 2 for value.



Table 2

Character Code	Code Value
A	0
B	1
C	2
D	3
E	4
F	5
G	6
H	7
J	8
K	9

Examples: 1A = 10.0 GHz
2H = 27.0 GHz

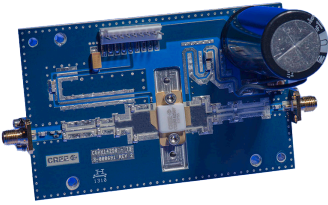

Product Ordering Information

Order Number	Description	Unit of Measure	Image
CGHV14250F	GaN HEMT	Each	
CGHV14250P	GaN HEMT	Each	
CGHV14250F-AMP	Test board with GaN HEMT installed, 1.2 - 1.4 GHz	Each	



For more information, please contact:

4600 Silicon Drive
Durham, North Carolina, USA 27703
www.wolfspeed.com/RF

Sales Contact
RFSales@wolfspeed.com

Notes

Disclaimer

Specifications are subject to change without notice. “Typical” parameters are the average values expected by Cree in large quantities and are provided for information purposes only. Cree products are not warranted or authorized for use as critical components in medical, life-saving, or life-sustaining applications, or other applications where a failure would reasonably be expected to cause severe personal injury or death. No responsibility is assumed by Cree for any infringement of patents or other rights of third parties which may result from use of the information contained herein. No license is granted by implication or otherwise under any patent or patent rights of Cree.