

THIS IS A C.A.D. GENERATED DRAWING
DO NOT MAKE MANUAL REVISIONS TO MASTER.



* UNLESS OTHERWISE SPECIFIED TOLERANCES
ON DECIMAL IS:

UNIT: MM

DIM	TOL	DIM	TOL
X.	±0.15	X'	±2.0'
X.X	±0.10	X.X'	±1.0'
X.XX	±0.05	X.XX'	±0.5'
X.XXX	±0.03	X.XXX'	±0.3'

ISSUE NUMBER

ORIGINAL

ADD NOTE 2 & 3,
ADD UNPLATED P/N
Peter Deng JUN.26/19

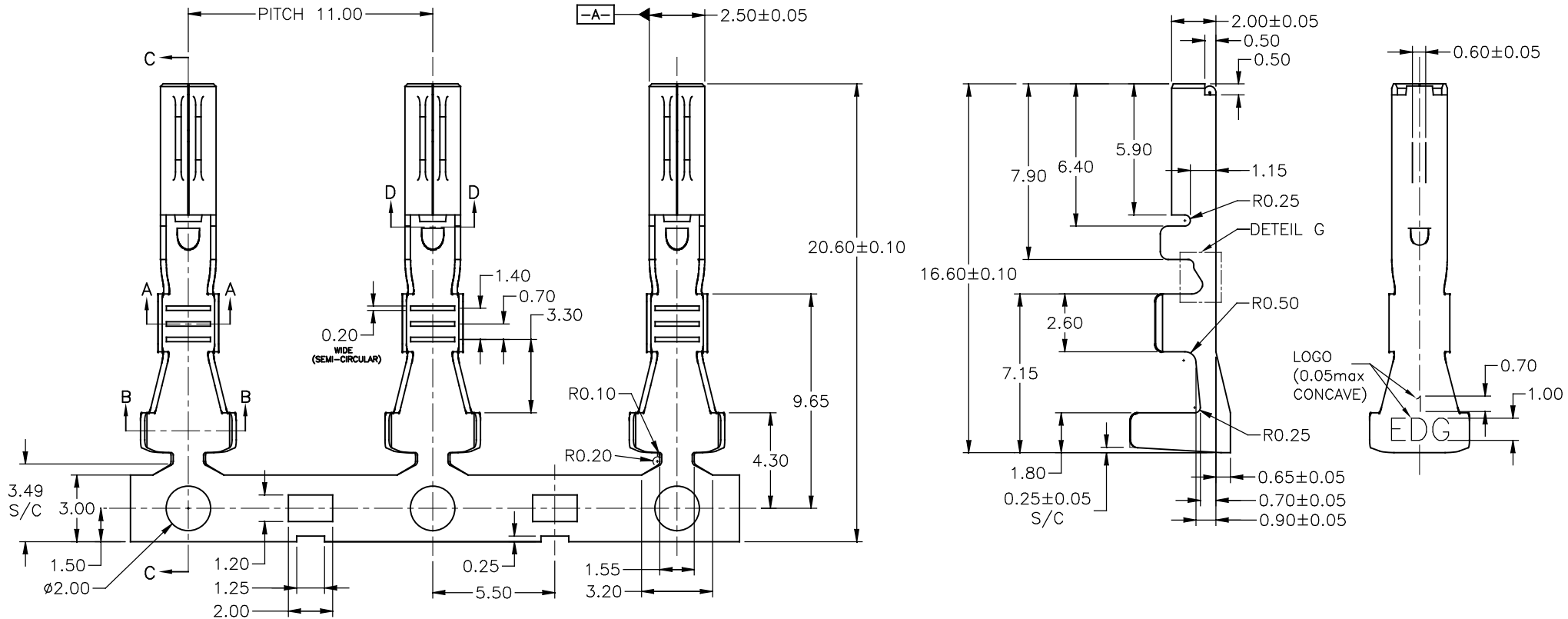

570-292-761	570-290-761	4.4±0.20	3.4±0.20	4.4±0.20	3.0±0.20	R1.60±0.05	R0.85±0.05	Brass C2680 H	AWG #14	ø3.10 max	4,000
570-293-741	570-291-741	4.4±0.20	2.7±0.20	4.4±0.20	2.7±0.20	R1.60±0.05	R0.75±0.05	Phosphor bronze C5191 1/2 H	AWG #20-16	ø3.10 max	4,000
570-292-741	570-290-741	4.4±0.20	2.7±0.20	4.4±0.20	2.7±0.20	R1.60±0.05	R0.75±0.05	Brass C2680 H	AWG #20-16	ø3.10 max	4,000
570-293-721	570-291-721	4.4±0.20	2.2±0.20	4.4±0.20	2.2±0.20	R1.40±0.05	R0.55±0.05	Phosphor bronze C5191 1/2 H	AWG #22-20	ø2.70 max	4,000
570-292-721	570-290-721	4.4±0.20	2.2±0.20	4.4±0.20	2.2±0.20	R1.40±0.05	R0.55±0.05	Brass C2680 H	AWG #22-20	ø2.70 max	4,000
UN-PLATED PART NO.	PLATED PART NO.	A1	A2	B1	B2	C1	C2	MATERIALS	AWG #	INS. DIA.	PCS/REEL

NOTES:

- MATERIAL: SEE TABLE, 0.25mm THICK.
- PLATING: 100-200 MICROINCHES OF BRIGHT TIN PLATING ALL OVER NICKEL 50-150 MICROINCHES UNDERPLATING.
- SALT SPRAY TEST MUST BE NO CORROSION AFTER 24H.
- PART SHALL BE FREE OF BURRS NOT EXCEEDING 0.02mm NO CRACKS ALLOW ON ANY SURFACES.
- TOOLING TO BE DESIGNED WITH ADJUSTMENT TO HOLD THIS DIMENSION.

570 SERIES FEMALE CONTACT



EDAC INC
TORONTO, ONTARIO
CANADA

YOUR CONNECTION TO QUALITY & SERVICE

THESE DRAWINGS AND SPECIFICATIONS ARE THE PROPERTY OF EDAC INC. AND SHALL NOT BE REPRODUCED, OR COPIED OR USED AS THE BASIS FOR THE MANUFACTURE OR SALE OF APPARATUS WITHOUT WRITTEN PERMISSION.

ACAD REFERENCE NO. 570-29X-7X1

DRAWN: Haley Hu

DATE: MAY.16/15

CHECKED:

DATE:

SCALE: (IN C.A.D. 1:1)

SHEET 1 OF 3

DRAWING NUMBER

570-29X-7X1

ISSUE

8

THIS IS A C.A.D. GENERATED DRAWING
DO NOT MAKE MANUAL REVISIONS TO MASTER.



* UNLESS OTHERWISE SPECIFIED TOLERANCES

ON DECIMAL IS:

UNIT: MM

DIM	TOL	DIM	TOL
X.	±0.15	X°	±2.0°
X.X	±0.10	X.X°	±1.0°
X.XX	±0.05	X.XX°	±0.5°
X.XXX	±0.03	X.XXX°	±0.3°

ISSUE NUMBER

ORIGINAL

SEE SHEET 1
Peter Deng JUN.26/19

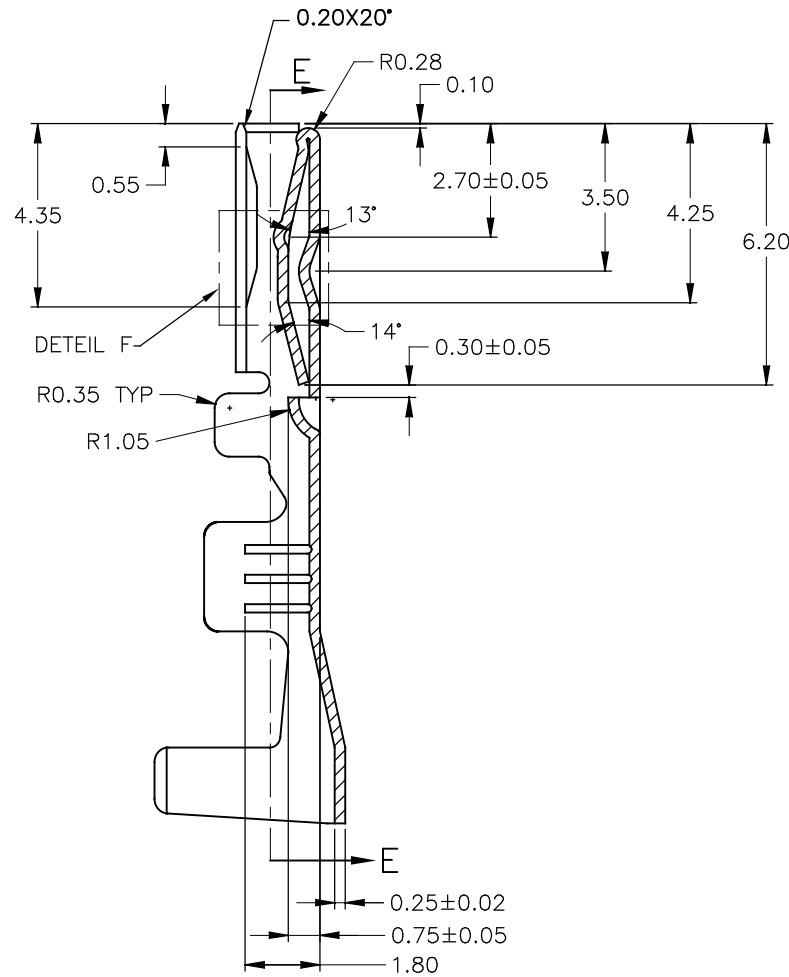

SECTION C-C
SCALE 1:1

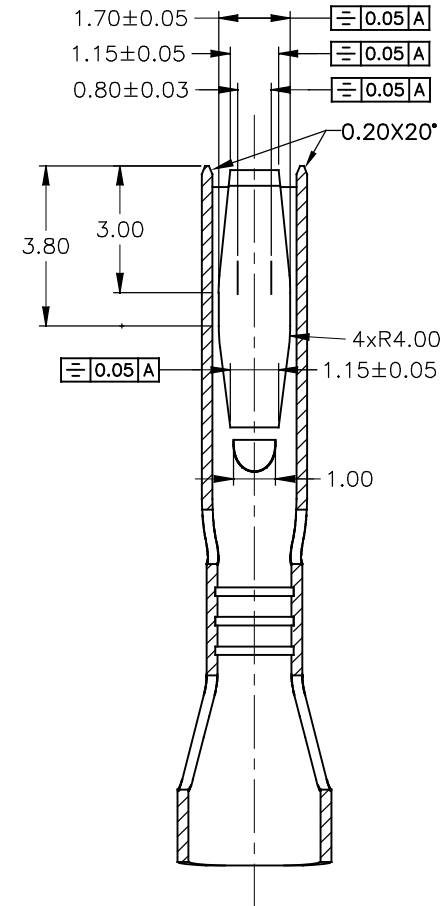

SECTION E-E
SCALE 1:1

570 SERIES FEMALE CONTACT

ACAD REFERENCE NO. 570-29X-7X1

DRAWN: Haley Hu

DATE: MAY.16/15

CHECKED:

DATE:

SCALE: (IN C.A.D. 1:1)

SHEET 2 OF 3

DRAWING NUMBER

570-29X-7X1

ISSUE

8



EDAC INC
TORONTO, ONTARIO
CANADA

YOUR CONNECTION TO QUALITY & SERVICE

THESE DRAWINGS AND SPECIFICATIONS
ARE THE PROPERTY OF EDAC INC. AND
SHALL NOT BE REPRODUCED, OR COPIED
OR USED AS THE BASIS FOR THE
MANUFACTURE OR SALE OF APPARATUS
WITHOUT WRITTEN PERMISSION.

THIS IS A C.A.D. GENERATED DRAWING
DO NOT MAKE MANUAL REVISIONS TO MASTER.



* UNLESS OTHERWISE SPECIFIED TOLERANCES

ON DECIMAL IS:

UNIT: MM

DIM	TOL	DIM	TOL
X.	±0.15	X°.	±2.0°
X.X	±0.10	X.X°	±1.0°
X.XX	±0.05	X.XX°	±0.5°
X.XXX	±0.03	X.XXX°	±0.3°

ISSUE NUMBER

ORIGINAL

①

SEE SHEET 1
Peter Deng JUN.26/19

②

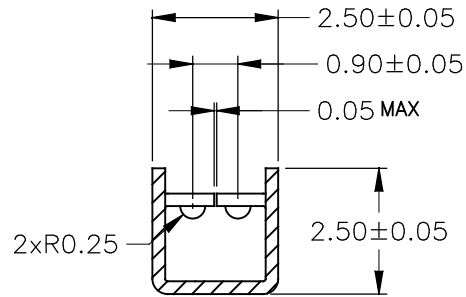

SECTION D-D
SCALE 1:1

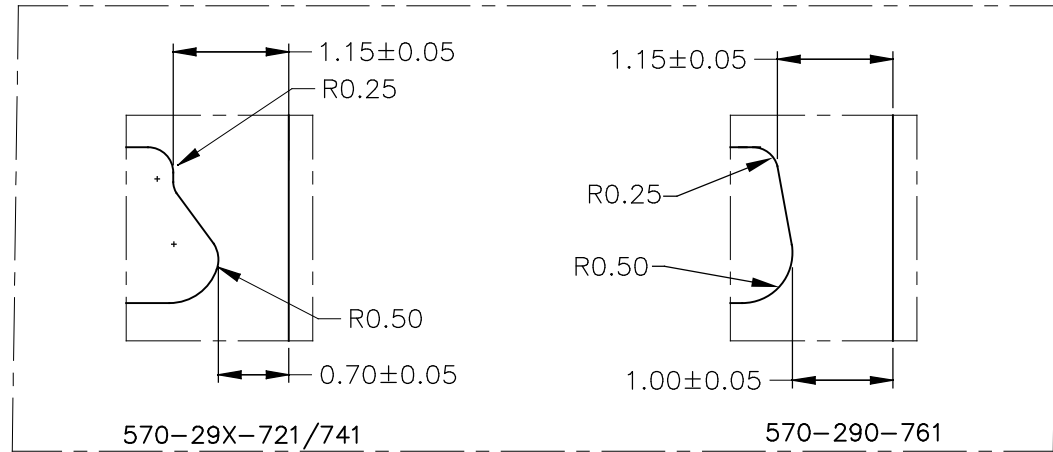

DETAIL G
SCALE 2:1

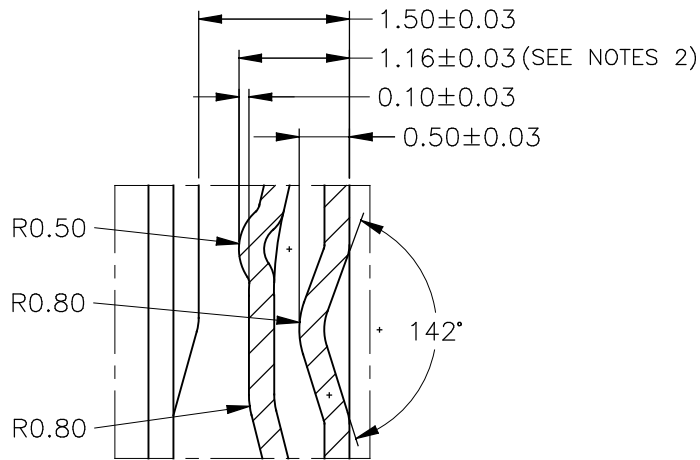

DETAIL F
SCALE 2:1

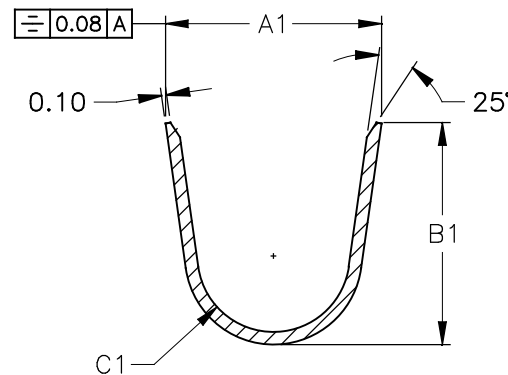

SECTION B-B
SCALE 1:1

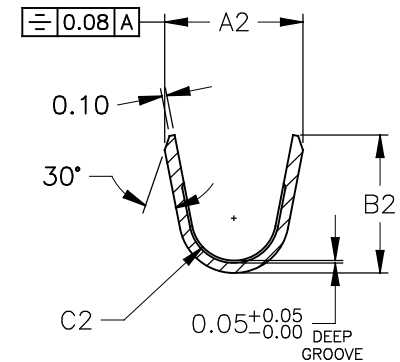

SECTION A-A
SCALE 1:1

570 SERIES FEMALE CONTACT

ACAD REFERENCE NO. 570-29X-7X1	
DRAWN: Haley Hu	DATE: MAY.16/15
CHECKED:	DATE:
SCALE: (IN C.A.D. 1:1)	SHEET 3 OF 3
DRAWING NUMBER 570-29X-7X1	ISSUE 8



EDAC INC
TORONTO, ONTARIO
CANADA

YOUR CONNECTION TO QUALITY & SERVICE

THESE DRAWINGS AND SPECIFICATIONS
ARE THE PROPERTY OF EDAC INC. AND
SHALL NOT BE REPRODUCED, OR COPIED
OR USED AS THE BASIS FOR THE
MANUFACTURE OR SALE OF APPARATUS
WITHOUT WRITTEN PERMISSION.