



Monsoon 2-in-1

Part No:
MA170.A.BI.001

Description:

2-in 1 Monsoon 2*5G/4G MIMO Permanent Mount Antenna with 3m TGC-200 & SMA(M)ST Connector

Features:

2*5G/4G MIMO Antenna
600-6000MHz
Permanent Mount [Screw Mount]
Worldwide 4G Bands including 3G/2G Fallback
IP69K Enclosure
Dimensions: 204*69*31 mm
Cable: 3 Meters TGC-200
Connector: SMA(M)ST
Custom Cables and Connectors Available
CE Certified
RoHS & Reach Compliant

1. Introduction	3
2. Specifications	4
3. Antenna Characteristics	8
4. Radiation Patterns	12
5. Mechanical Drawing	29
6. Packaging	30
<hr/>	
Changelog	31

Taoglas makes no warranties based on the accuracy or completeness of the contents of this document and reserves the right to make changes to specifications and product descriptions at any time without notice. Taoglas reserves all rights to this document and the information contained herein. Reproduction, use or disclosure to third parties without express permission is strictly prohibited.

© Taoglas



1. Introduction



The Taoglas Monsoon MA170 antenna is a custom profile, fully IP69K Waterproof external M2M antenna for use on containers for global telematics services. The MA170 delivers best in class 5G/4G antenna performance.

Typical applications include:

- HD Video over LTE
- First Responder and Emergency Services
- Intelligent Transport Systems
- Internet of Things (IoT market)
- High Definition Video Broadcast Systems
- Wireless LTE MIMO M2M Devices
- Digital Signage

LTE 4G applications demand high speed data uplink and downlink. High efficiency and high gain MIMO antennas are necessary to achieve the required signal to noise ratio and throughput required to solve these challenges. Taoglas also takes care to have high isolation between the two MIMO antennas to prevent self-interference. The MA170 does not require a ground plane. Low loss cables are used to keep efficiency high over long cable lengths. In contrast, smaller MIMO antennas with poorer quality thinner cables will have much reduced efficiency and isolation, which would lead to a large drop in system throughput or drops, and may indeed not make a system connection at all.

The antenna cable length and connector type can be customizable, please contact your regional Taoglas sales office for support.

2. Specifications

5G/4G MIMO1 Antenna									
Band	Frequency (MHz)		Efficiency (%)	Average Gain (dB)	Peak Gain (dBi)	Impedance	Max Input Power	Polarization	Radiation Pattern
4G/3G Band 12,13,14,17,28,29	698~824	Free space	34	-4.64	0.79	50 Ω	10W	Linear	Omni-Directional
		On 30x30cm Ground Plane	42	-3.91	1.05				
4G/3G/NB-IoT/Cat M Band 5,8,18,19,20,26,27	824~960	Free space	48	-3.26	2.74				
		On 30x30cm Ground Plane	43	-3.74	2.21				
5GNR/4G Band 21,32,74,75,76	1427~1518	Free space	53	-2.74	2.66				
		On 30x30cm Ground Plane	48	-3.18	4.49				
4G/3G Band 1,2,3,4,9,23,25,35,39,66	1710~2200	Free space	60	-2.20	3.83				
		On 30x30cm Ground Plane	58	-2.40	5.25				
4G/3G Band 7,30,38,40,41	2300~2690	Free space	52	-2.86	4.04				
		On 30x30cm Ground Plane	49	-3.14	5.86				
5GNR/4G Band 22,42,48,77,78,79	3300~5000	Free space	46	-3.53	4.12				
		On 30x30cm Ground Plane	42	-4.09	6.39				
LTE5200/ Wi-Fi 5800	5150~5925	Free space	13	-8.97	-0.01				
		On 30x30cm Ground Plane	9	-10.72	0.65				

5G/4G MIMO2 Antenna

Band	Frequency (MHz)		Efficiency (%)	Average Gain (dB)	Peak Gain (dBi)	Impedance	Max Input Power	Polarization	Radiation Pattern
4G/3G Band 12,13,14,17,28,29	698~824	Free space	34	-4.71	1.11	50 Ω	10W	Linear	Omni-Directional
		On 30x30cm Ground Plane	43	-3.86	1.00				
4G/3G/NB-IoT/Cat M Band 5,8,18,19,20,26,27	824~960	Free space	44	-3.63	2.74				
		On 30x30cm Ground Plane	39	-4.15	1.94				
5G NR/4G Band 21,32,74,75,76	1427~1518	Free space	52	-2.85	2.48				
		On 30x30cm Ground Plane	49	-3.09	4.35				
4G/3G Band 1,2,3,4,9,23,25,35,39,66	1710~2200	Free space	63	-1.98	4.16				
		On 30x30cm Ground Plane	61	-2.13	5.23				
4G/3G Band 7,30,38,40,41	2300~2690	Free space	53	-2.77	4.07				
		On 30x30cm Ground Plane	51	-2.94	6.03				
5G NR/4G Band 22,42,48,77,78,79	3300~5000	Free space	54	-2.79	4.33				
		On 30x30cm Ground Plane	50	-3.18	6.41				
LTE5200/ Wi-Fi 5800	5150~5925	Free space	22	-6.63	2.42				
		On 30x30cm Ground Plane	21	-7.10	5.65				

Mechanical	
Dimensions	203.95 x 68.96 x 30.95 mm
Cable	3000mm TGC-200
Connector	SMA(M)
Casing	PC+ABS
Adhesive	3M 9448HK + CR4305
Sealant	Rubber Stopper
Weight	550 g
Environmental	
Protection	IP67
Corrosion	5% NaCl for 96hrs - Nickel plated steel base and thread
Temperature Range	-40°C to +85°C
Thermal Shock	100 cycles -40°C to +85°C
Humidity	Non-condensing 65°C 95% RH
Shock (Drop Test)	1m drop on concrete 6 axes

5G/4G Bands			
Band Number	5GNR / FR1 / LTE / LTE-Advanced / WCDMA / HSPA / HSPA+ / TD-SCDMA		
	Uplink	Downlink	Covered
1	UL: 1920 to 1980	DL: 2110 to 2170	✓
2	UL: 1850 to 1910	DL: 1930 to 1990	✓
3	UL: 1710 to 1785	DL: 1805 to 1880	✓
4	UL: 1710 to 1755	DL: 2110 to 2155	✓
5	UL: 824 to 849	DL: 869 to 894	✓
7	UL: 2500 to 2570	DL: 2620 to 2690	✓
8	UL: 880 to 915	DL: 925 to 960	✓
9	UL: 1749.9 to 1784.9	DL: 1844.9 to 1879.9	✓
11	UL: 1427.9 to 1447.9	DL: 1475.9 to 1495.9	✓
12	UL: 699 to 716	DL: 729 to 746	✓
13	UL: 777 to 787	DL: 746 to 756	✓
14	UL: 788 to 798	DL: 758 to 768	✓
17	UL: 704 to 716	DL: 734 to 746	✓
18	UL: 815 to 830	DL: 860 to 875	✓
19	UL: 830 to 845	DL: 875 to 890	✓
20	UL: 832 to 862	DL: 791 to 821	✓
21	UL: 1447.9 to 1462.9	DL: 1495.9 to 1510.9	✓
22	UL: 3410 to 3490	DL: 3510 to 3590	✓
23	UL: 2000 to 2020	DL: 2180 to 2200	✓
24	UL: 1625.5 to 1660.5	DL: 1525 to 1559	✓
25	UL: 1850 to 1915	DL: 1930 to 1995	✓
26	UL: 814 to 849	DL: 859 to 894	✓
27	UL: 807 to 824	DL: 852 to 869	✓
28	UL: 703 to 748	DL: 758 to 803	✓
29	UL: -	DL: 717 to 728	✓
30	UL: 2305 to 2315	DL: 2350 to 2360	✓
31	UL: 452.5 to 457.5	DL: 462.5 to 467.5	✗
32	UL: -	DL: 1452 - 1496	✓
35		1850 to 1910	✓
38		2570 to 2620	✓
39		1880 to 1920	✓
40		2300 to 2400	✓
41		2496 to 2690	✓
42		3400 to 3600	✓
43		3600 to 3800	✓
48		3550 to 3700	✓
66	UL: 1710-1780	DL: 2110-2200	✓
71		617 to 698	✓
74/75/76		1427 to 1518	✓
78		3300 to 3800	✓
79		4400 to 5000	✓
85	698-716	728-746	✓

3. Antenna Characteristics

3.1 Return Loss – 5G/4G MIMO1 and MIMO2 (Free space)

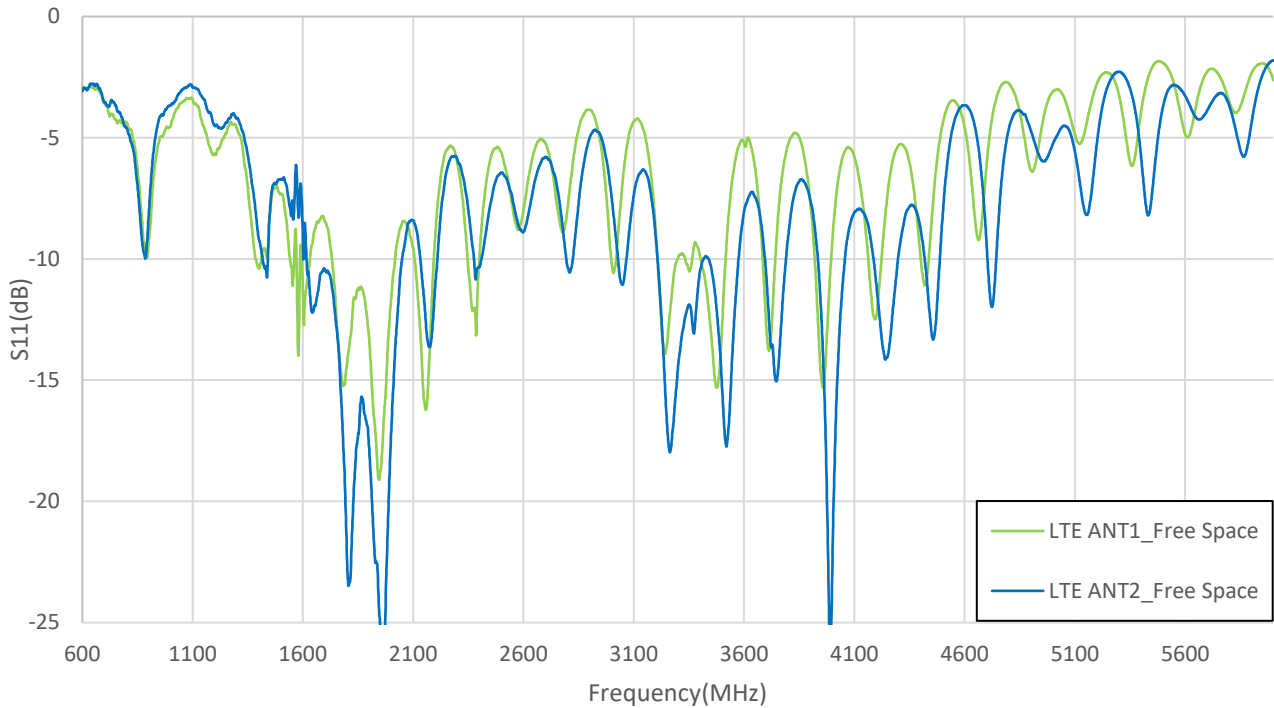

3.2 Return Loss – 5G/4G MIMO1 and MIMO2 (30cm SQ Ground plane)

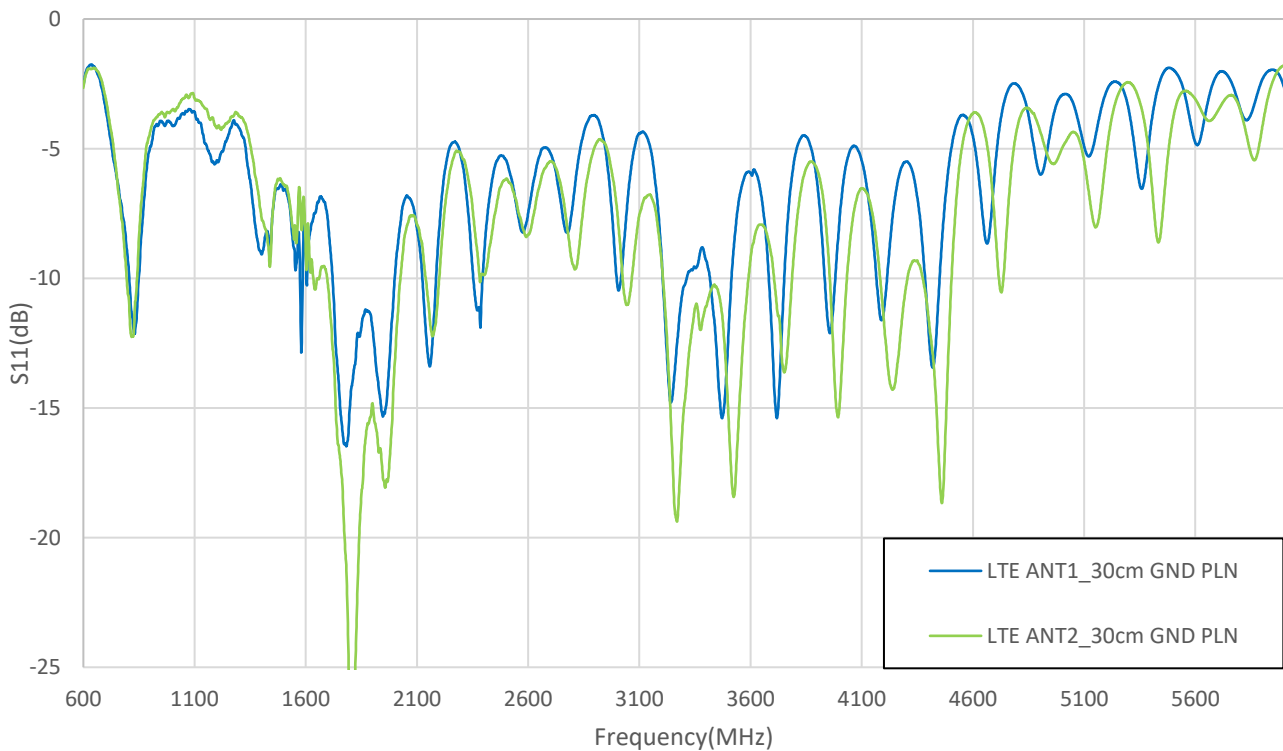

3.3 Efficiency – 5G/4G MIMO1 and MIMO2 (Free space)

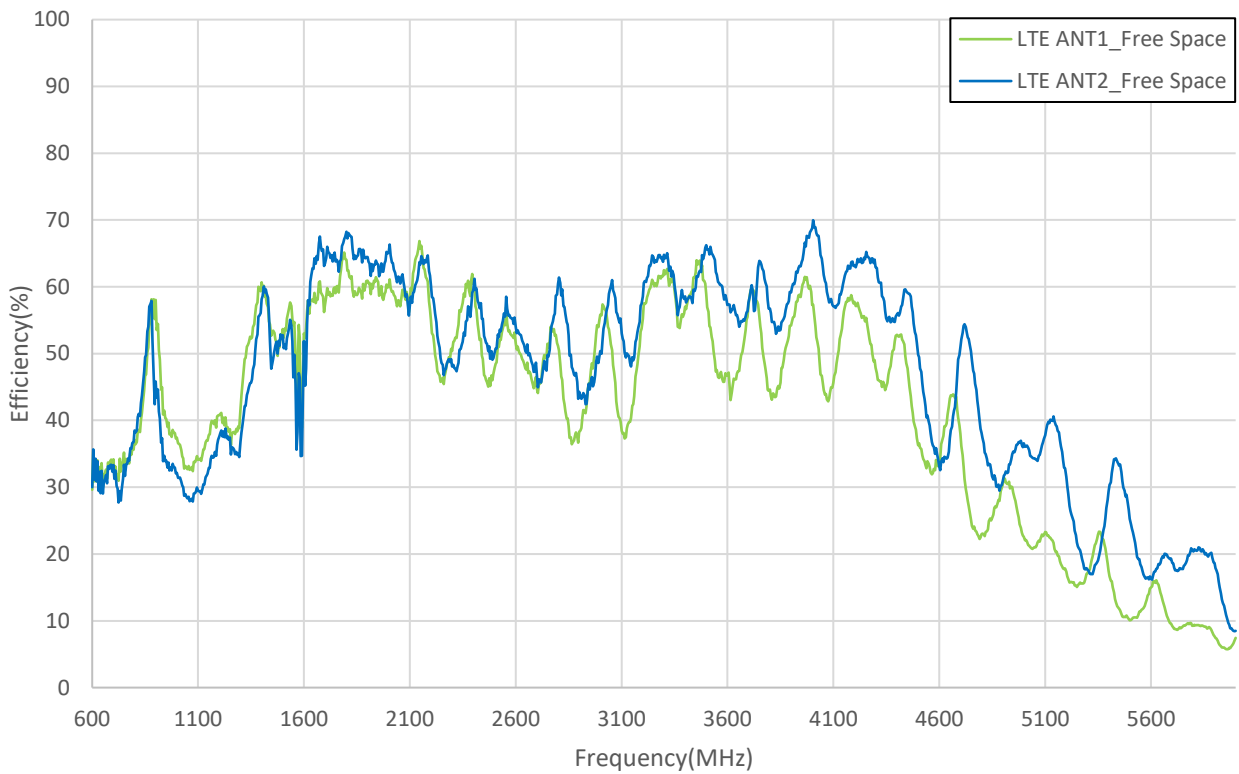

3.4 Efficiency – 5G/4G MIMO1 and MIMO2 (30cm SQ Ground plane)

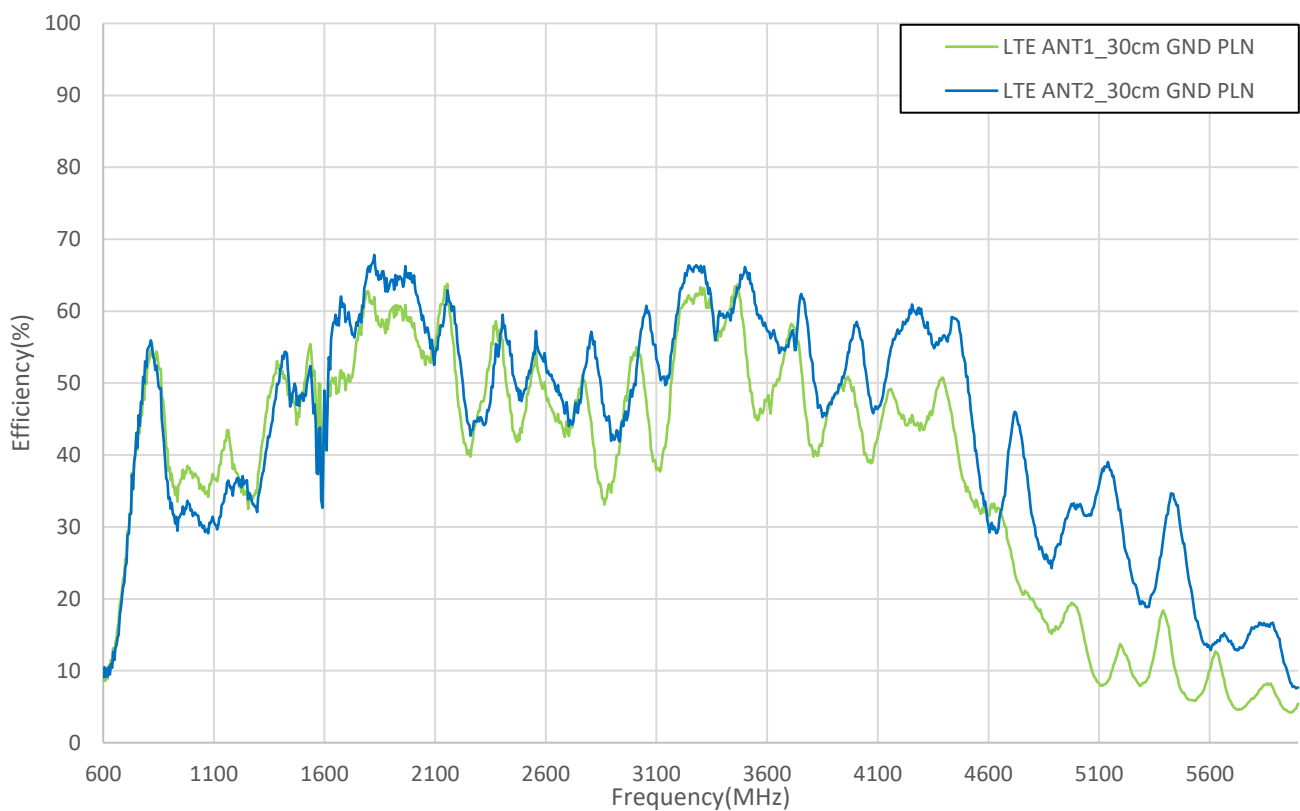

3.5 Peak Gain – 5G/4G MIMO1 and MIMO2 (Free space)

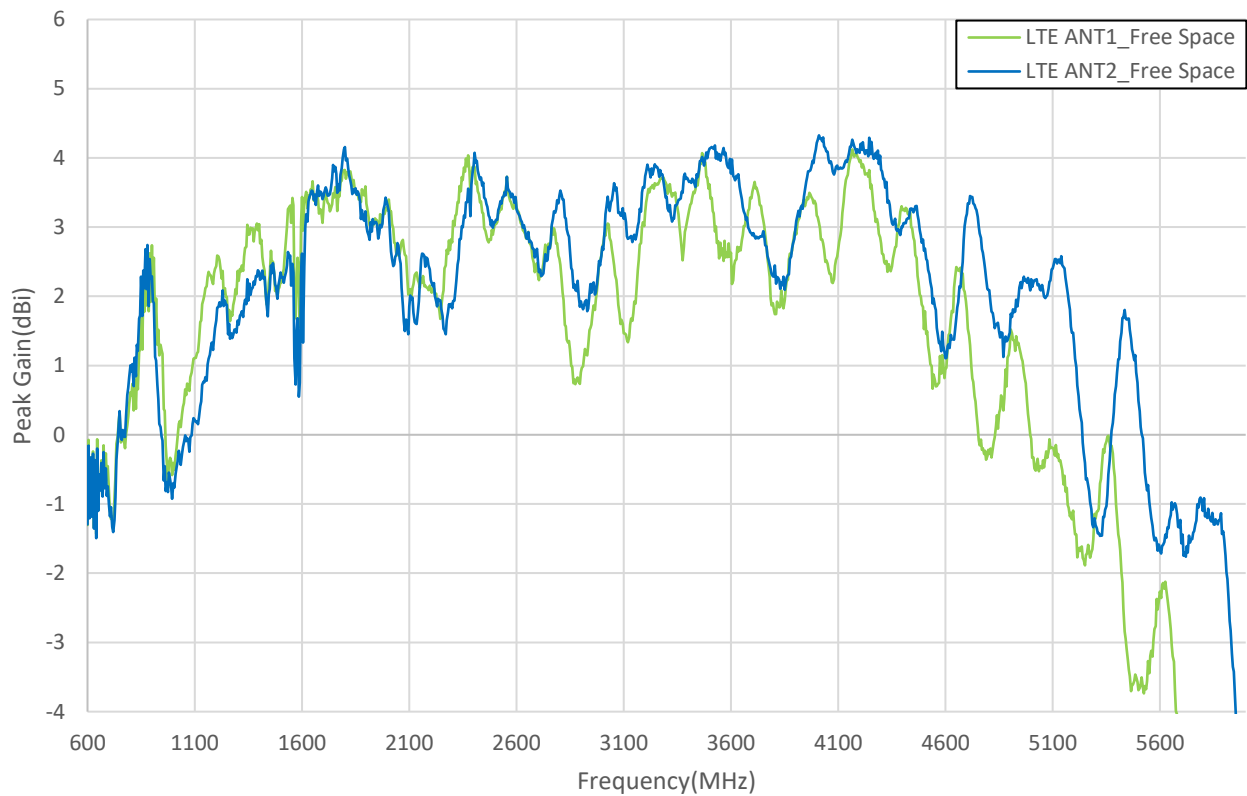

3.6 Peak Gain – 5G/4G MIMO1 and MIMO2 (30cm SQ Ground plane)

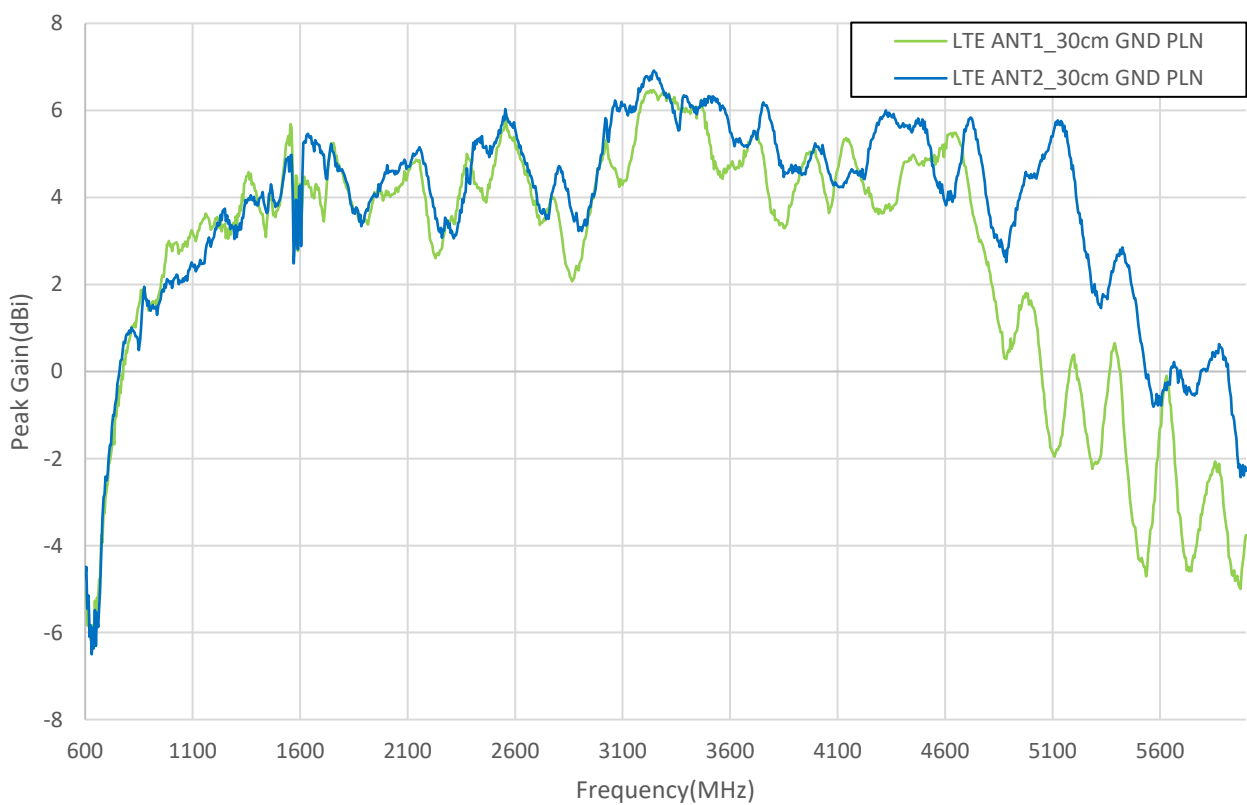

3.7 Average Gain – 5G/4G MIMO1 and MIMO2 (Free space)

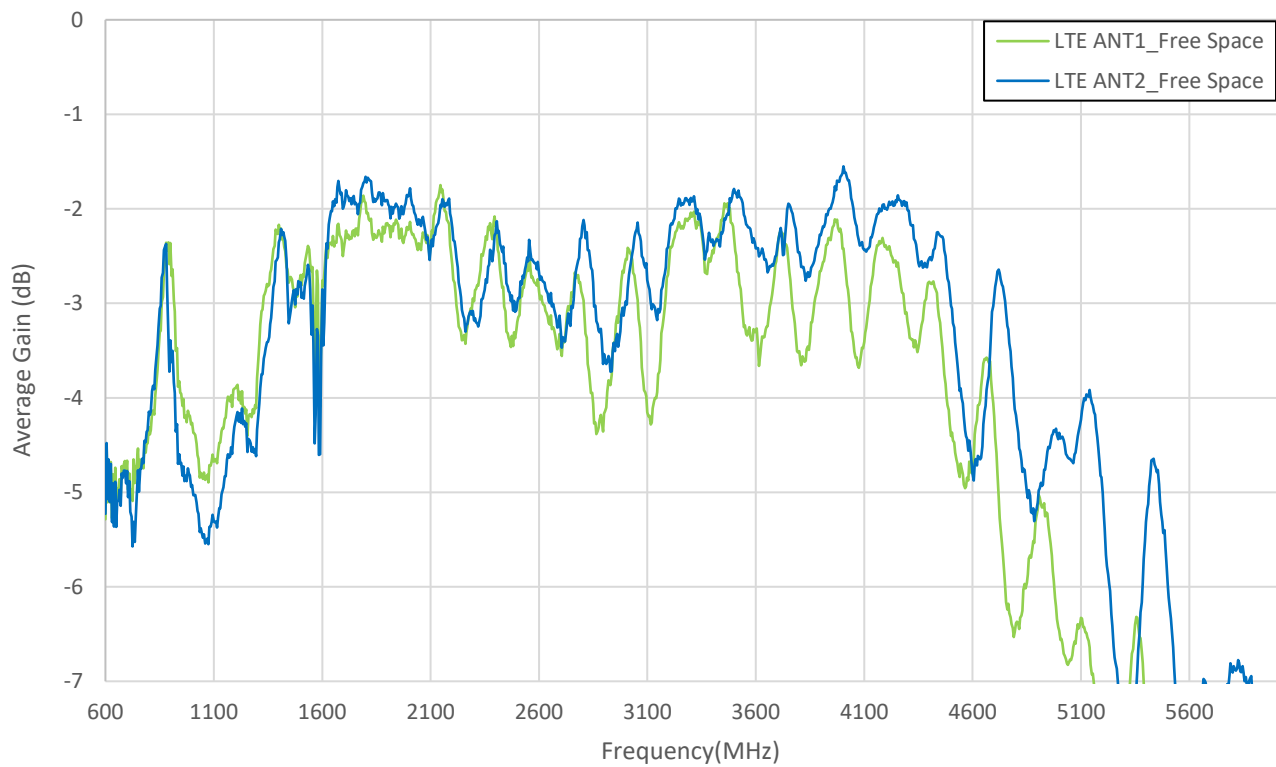

3.8 Average Gain – 5G/4G MIMO1 and MIMO2 (30cm SQ Ground plane)

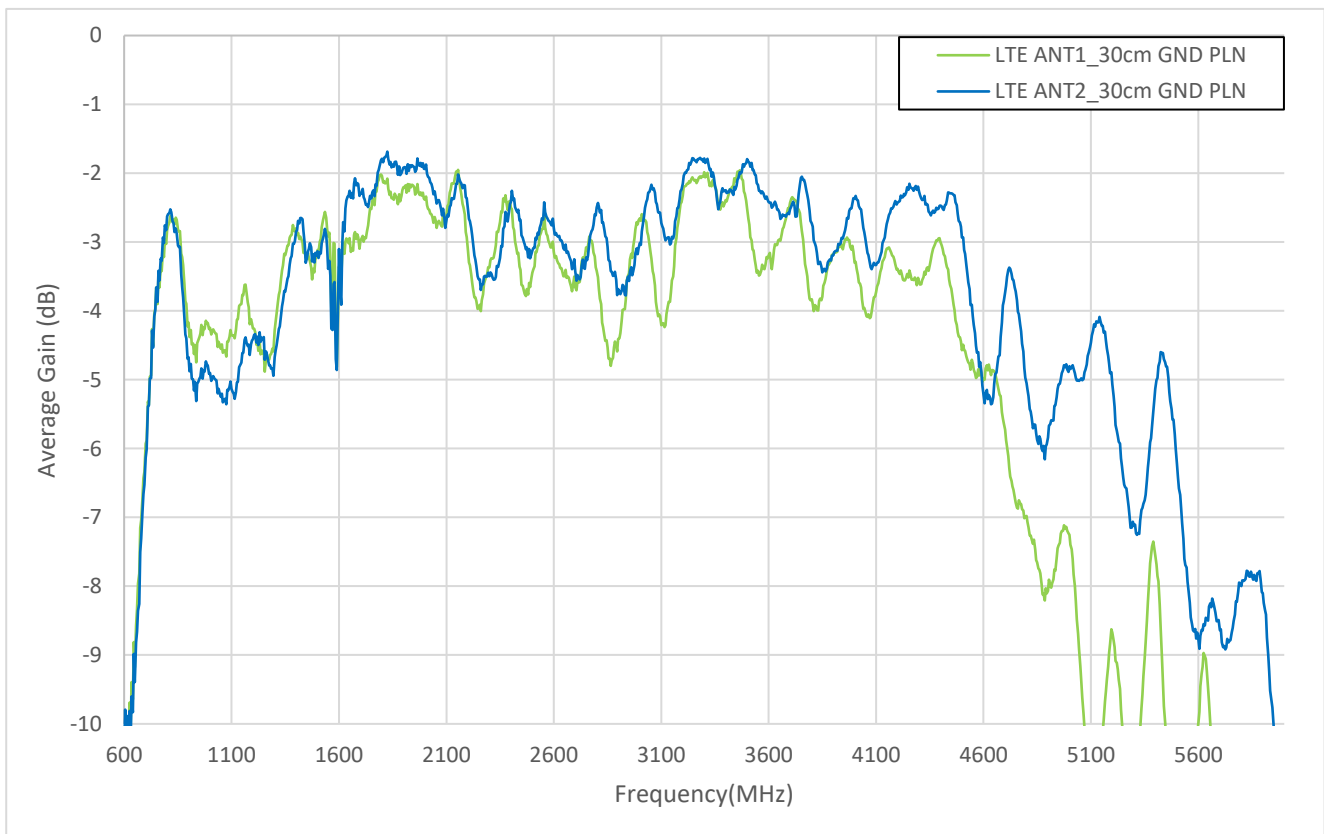

4. Radiation Patterns

4.1 Test Setup



Free space



On 30*30cm GND

4.2 2D & 3D Radiation Patterns – Free space

617MHz (MIMO1)

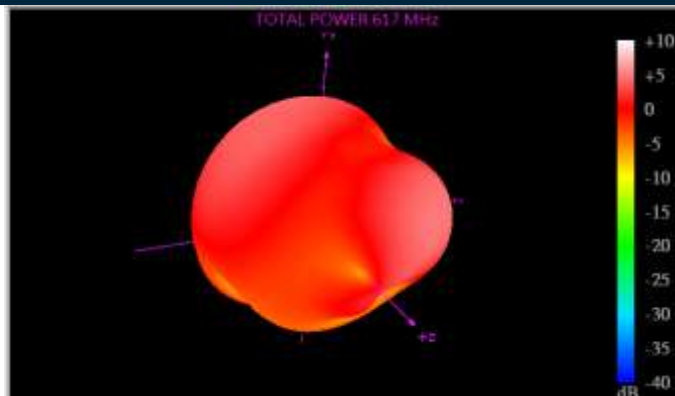

XY Plane

XZ Plane

YZ Plane

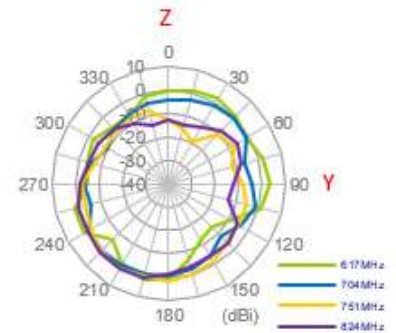
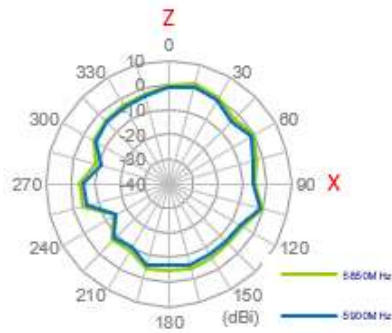
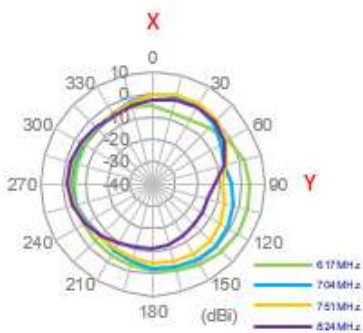

704MHz (MIMO1)

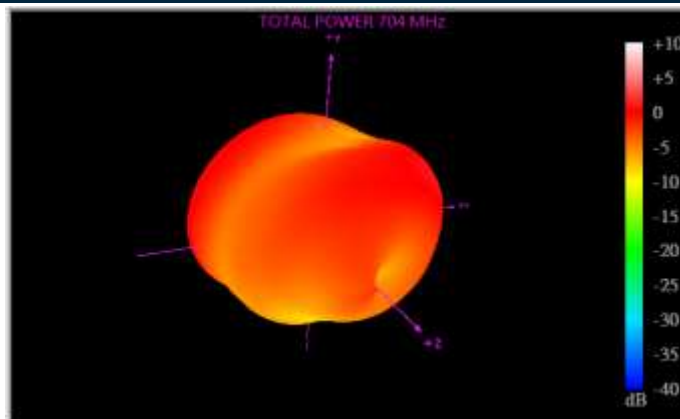

XY Plane

XZ Plane

YZ Plane

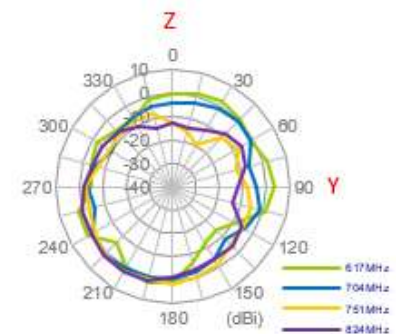
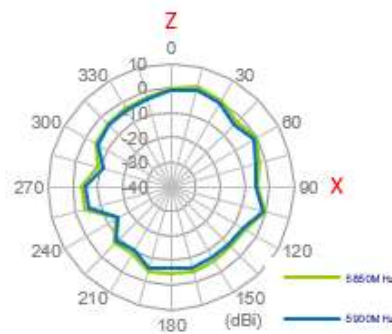
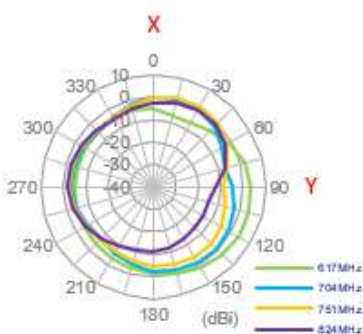

751MHz (MIMO1)

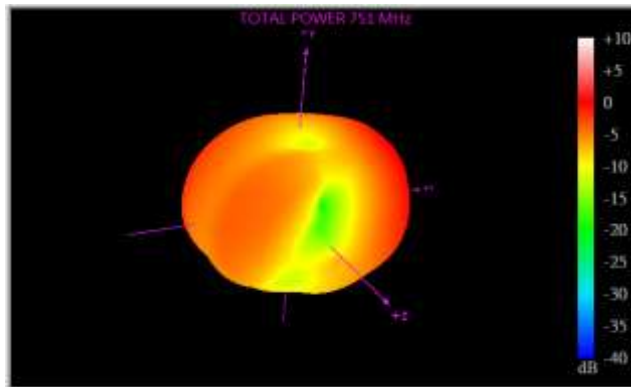

XY Plane

XZ Plane

YZ Plane

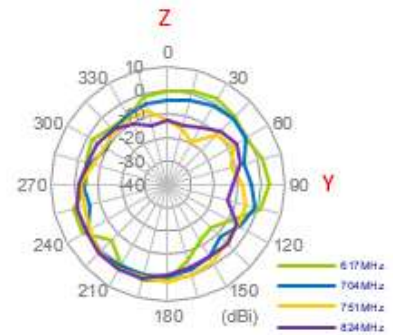
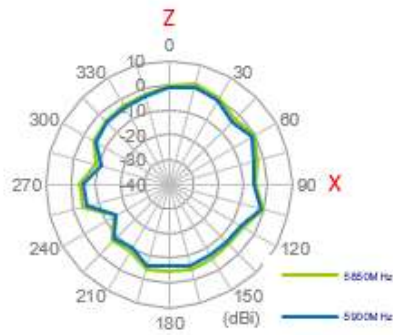
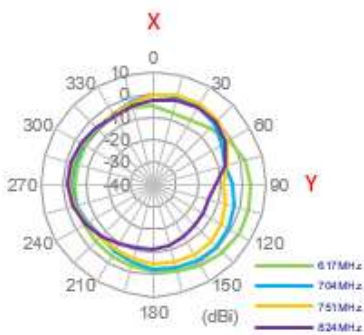

824MHz (MIMO1)

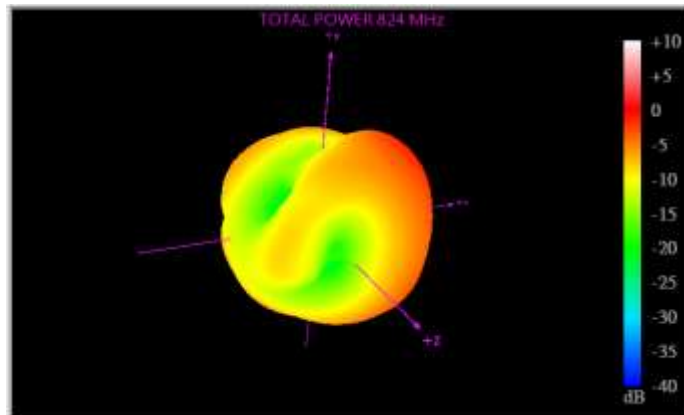

XY Plane

XZ Plane

YZ Plane

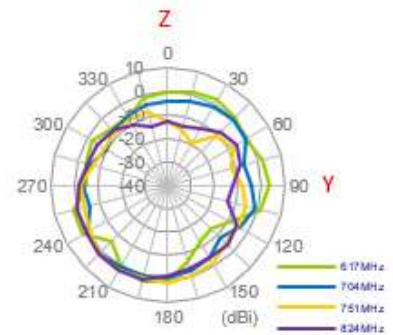
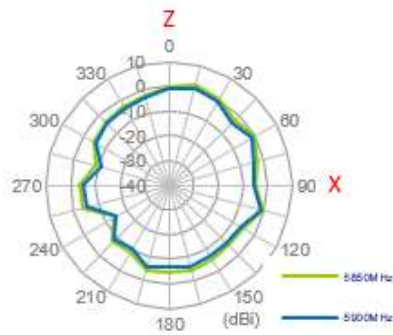
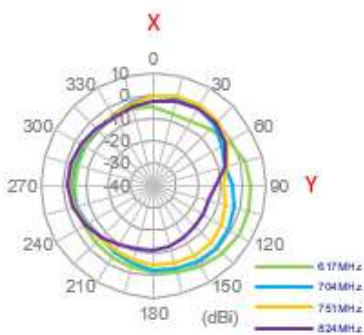

960MHz (MIMO1)

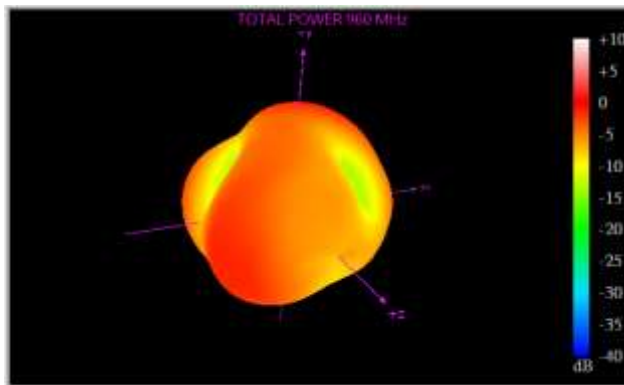

XY Plane

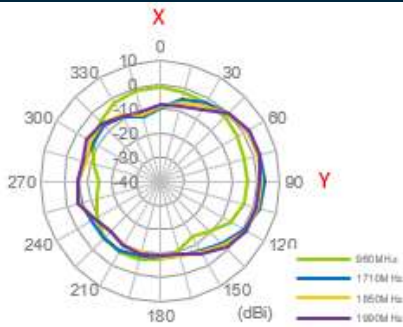

XZ Plane

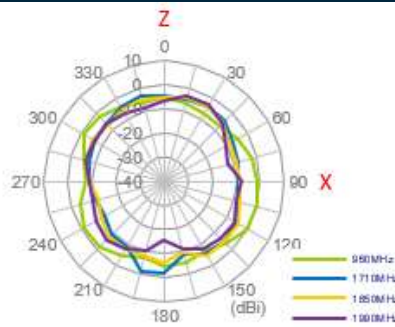

YZ Plane

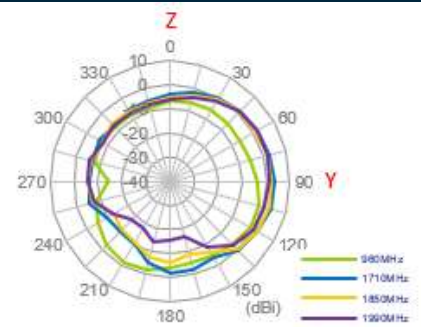

1710MHz (MIMO1)

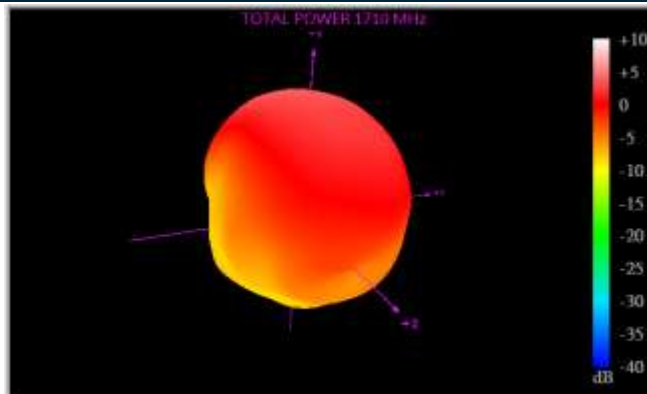

XY Plane

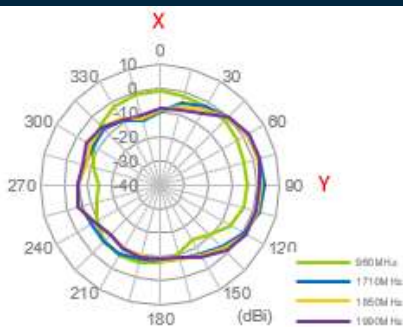

XZ Plane

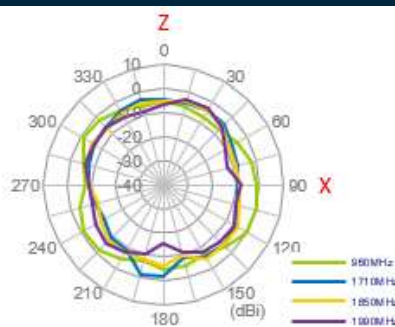

YZ Plane

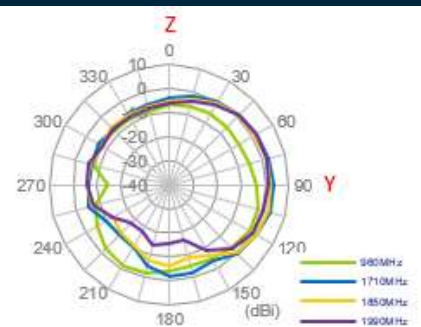

1850MHz (MIMO1)

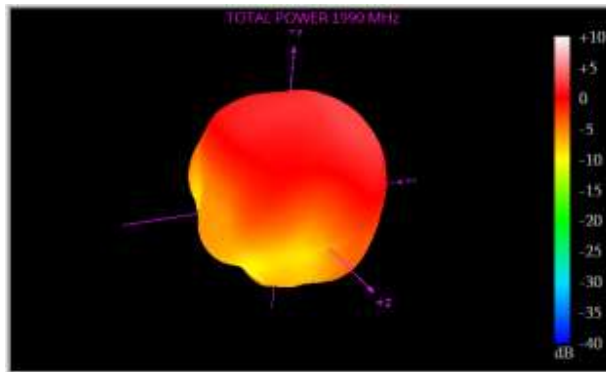

XY Plane

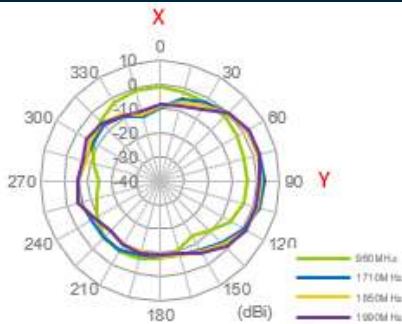

XZ Plane

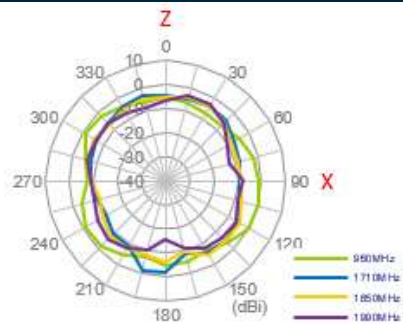

YZ Plane

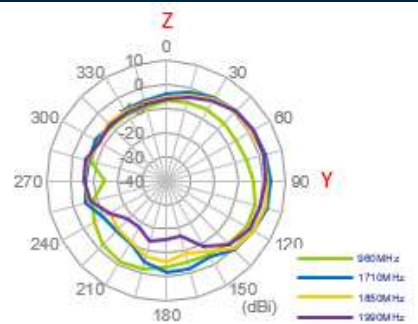

1990MHz (MIMO1)

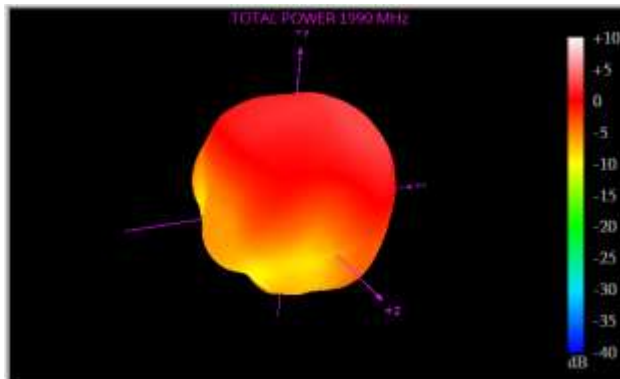

XY Plane

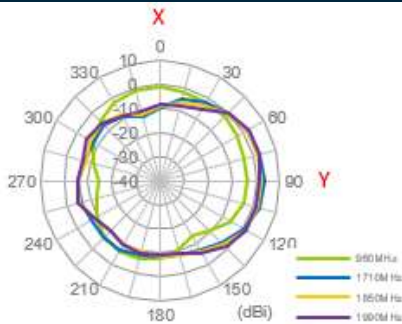

XZ Plane

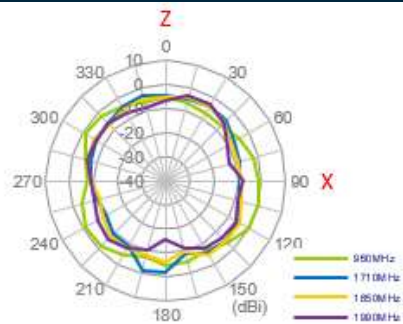

YZ Plane

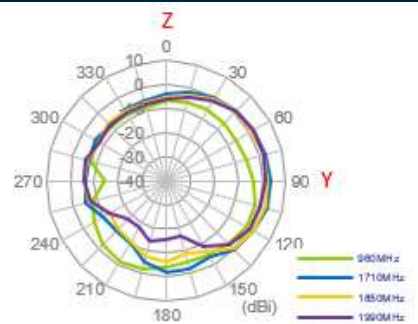

2170MHz (MIMO1)

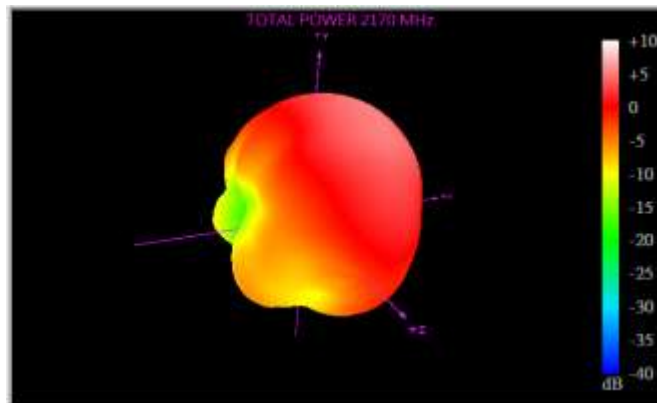

XY Plane

XZ Plane

YZ Plane

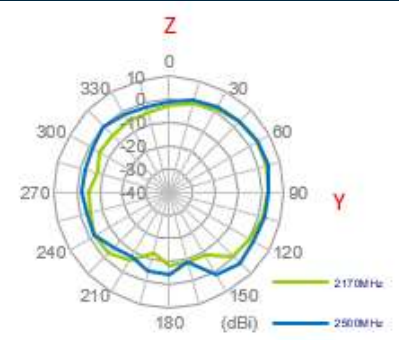
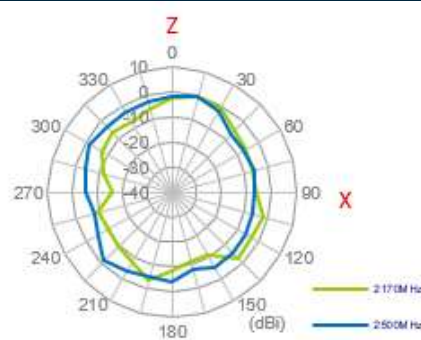
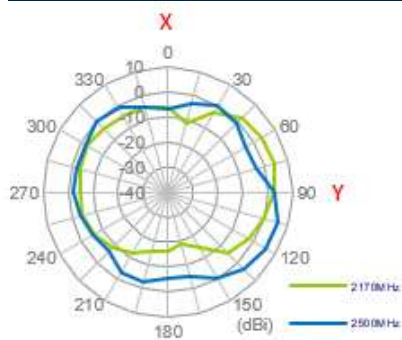

2500MHz (MIMO1)

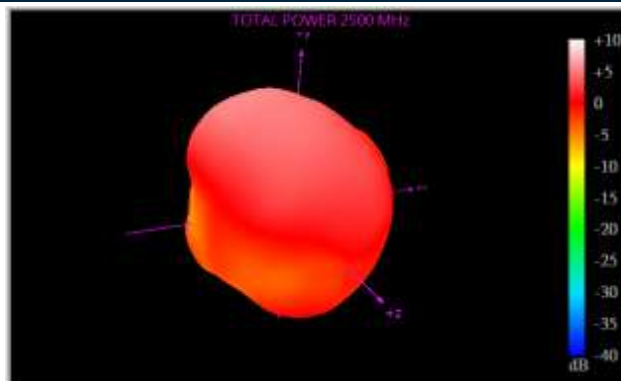

XY Plane

XZ Plane

YZ Plane

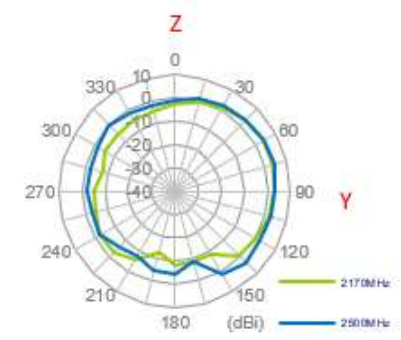
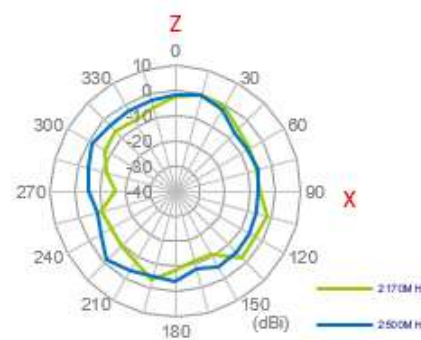
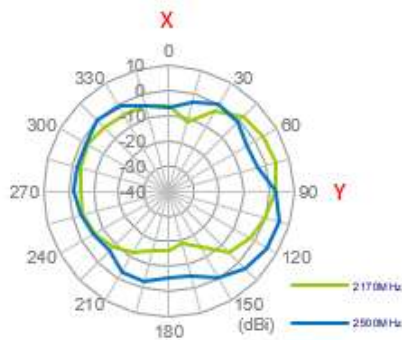

2690MHz (MIMO1)

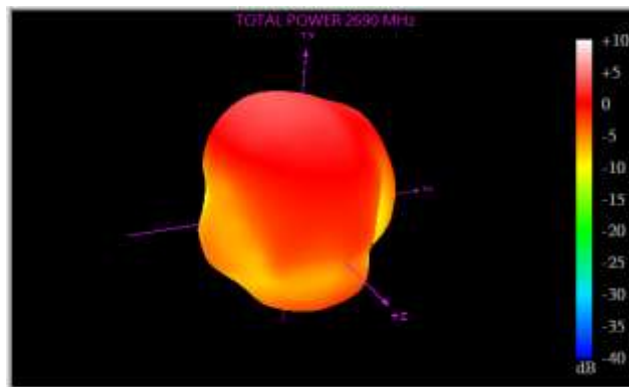

XY Plane

XZ Plane

YZ Plane

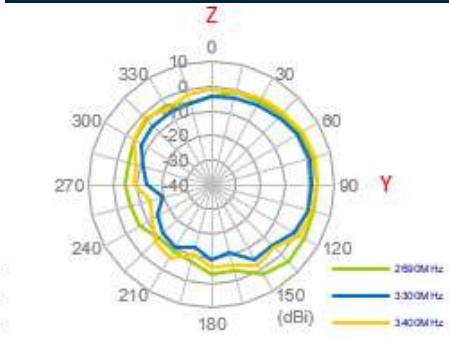
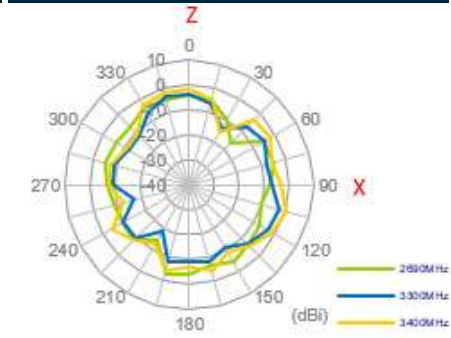
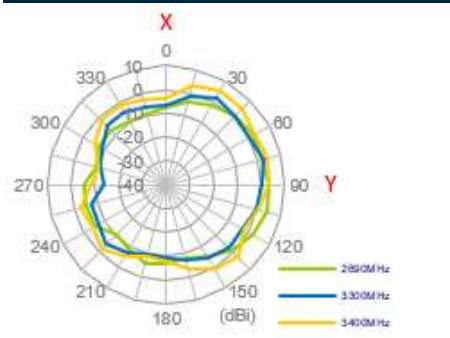

3300MHz (MIMO1)

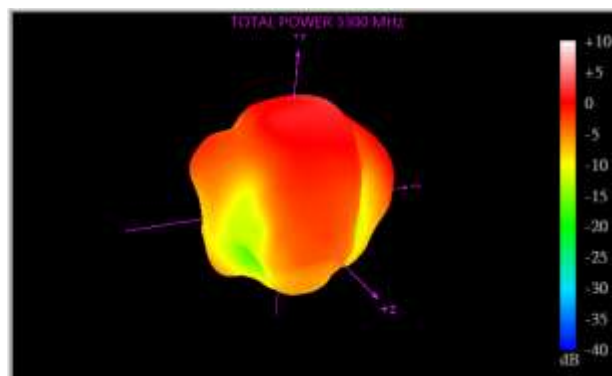

XY Plane

XZ Plane

YZ Plane

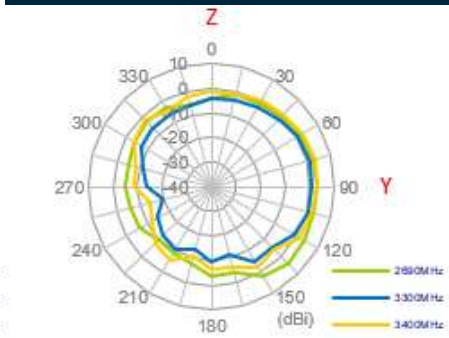
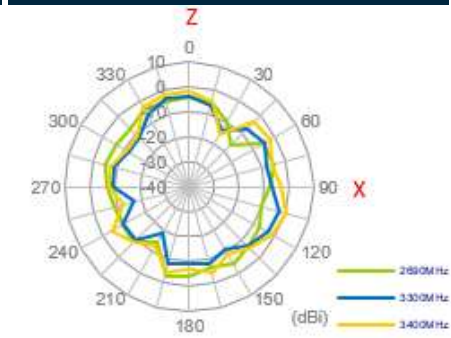
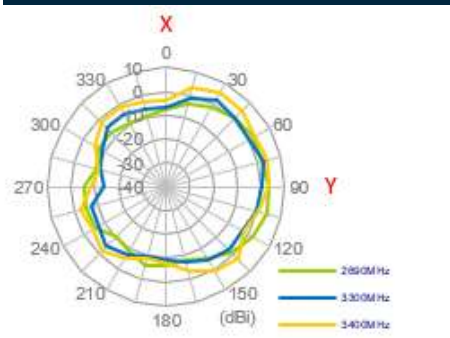

3400MHz (MIMO1)

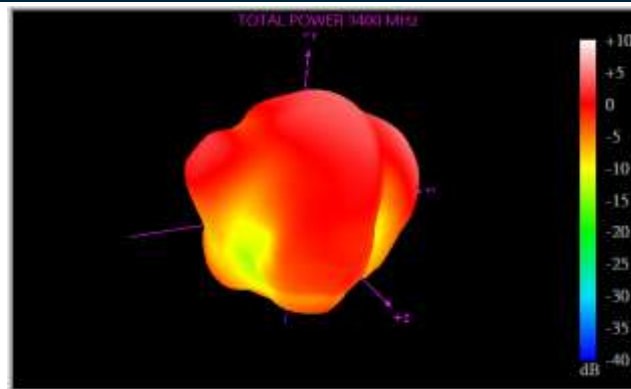

XY Plane

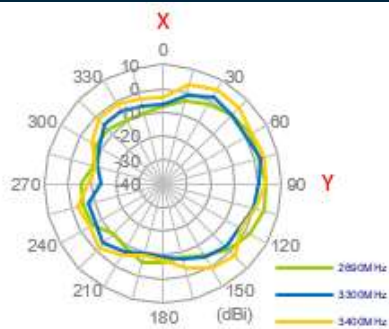

XZ Plane

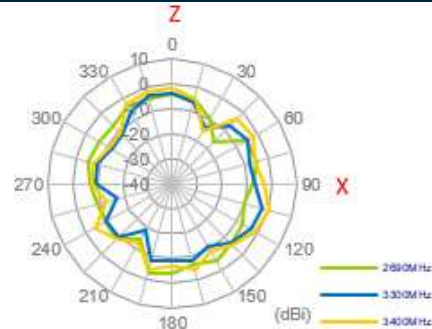

YZ Plane

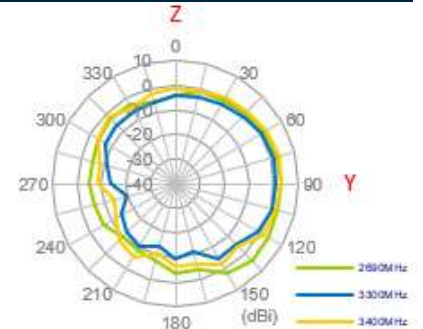

150MHz (MIMO1)

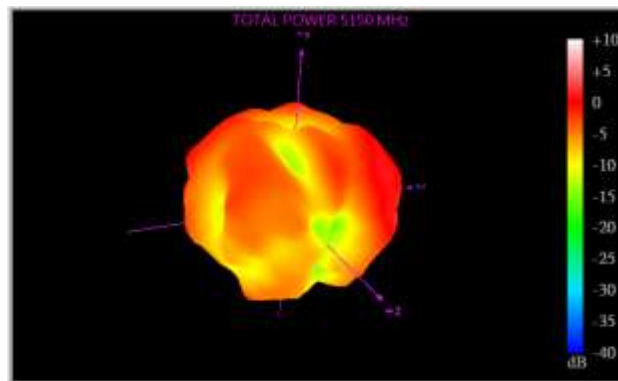

XY Plane

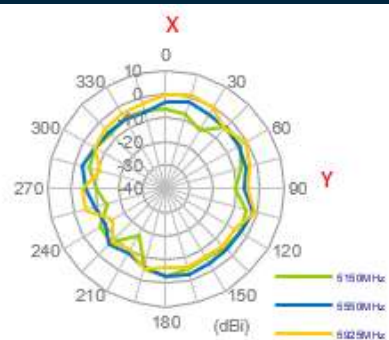

XZ Plane

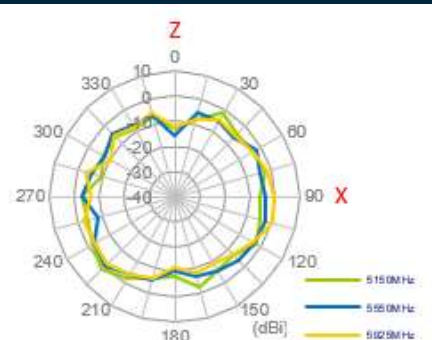

YZ Plane

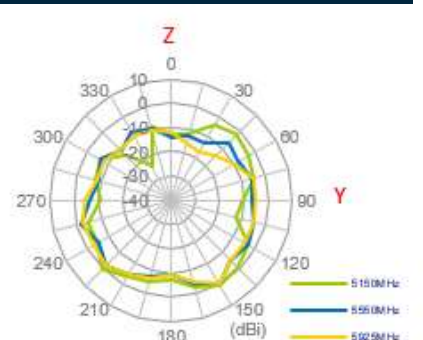

5550MHz (MIMO1)

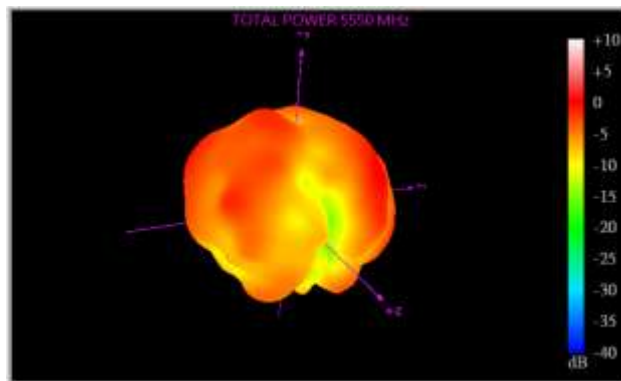

XY Plane

XZ Plane

YZ Plane

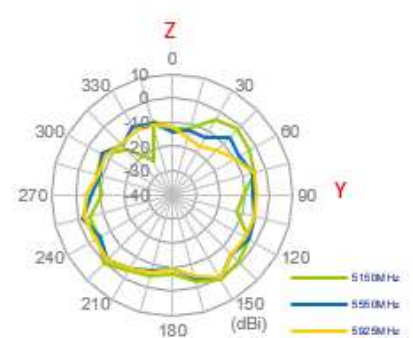
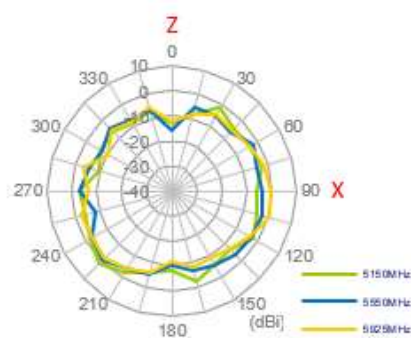
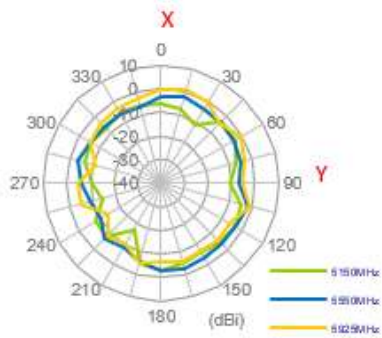

5925MHz (MIMO1)

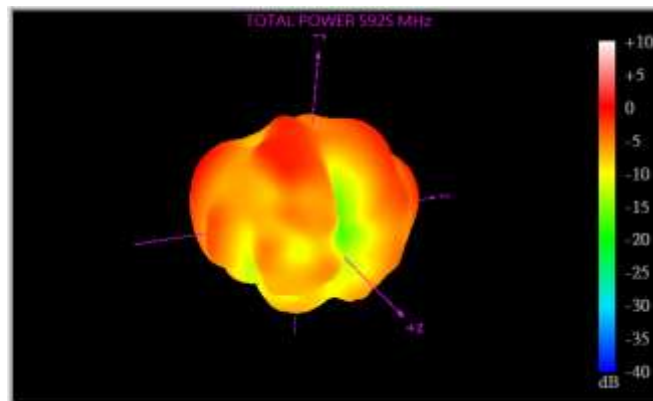

XY Plane

XZ Plane

YZ Plane

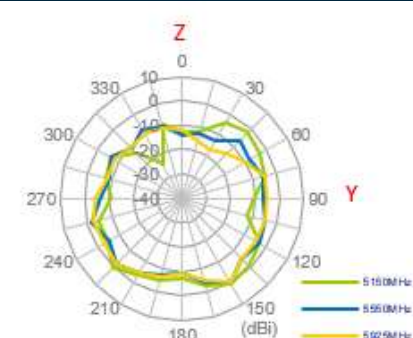
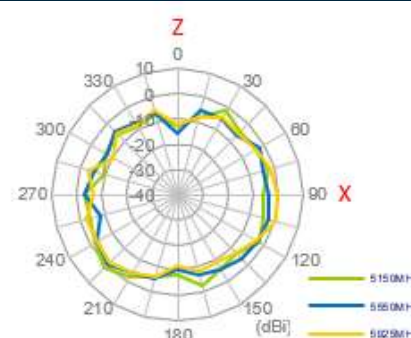
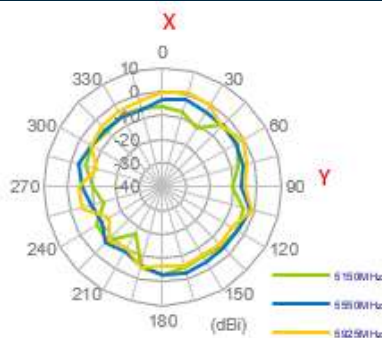

617MHz (MIMO2)

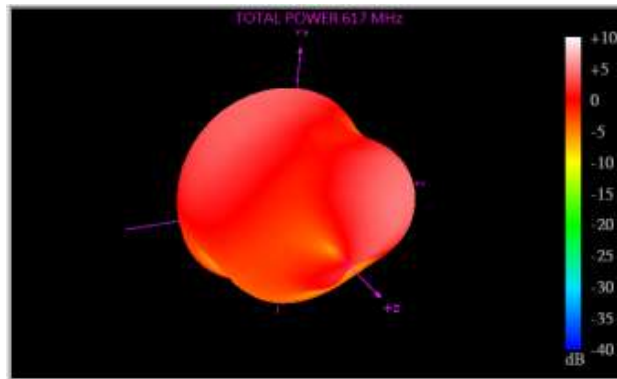

XY Plane

XZ Plane

YZ Plane

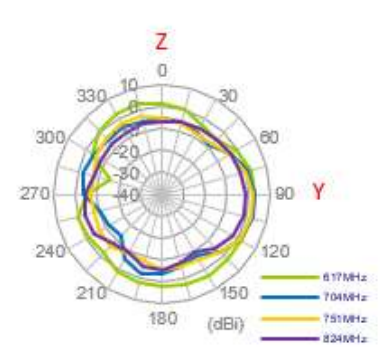
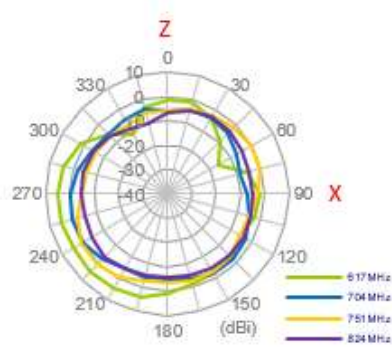
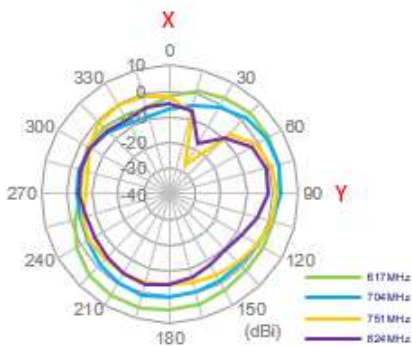

704MHz (MIMO2)

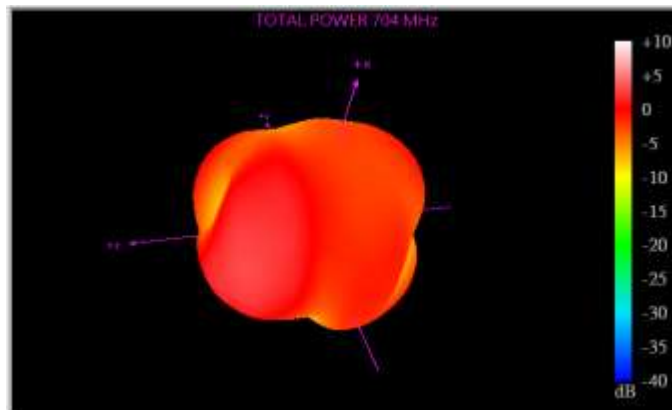

XY Plane

XZ Plane

YZ Plane

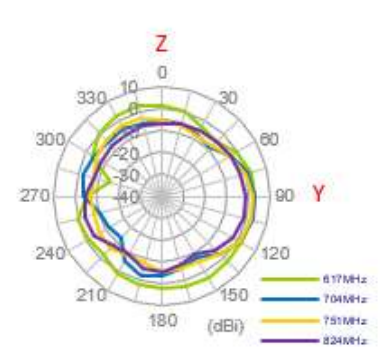
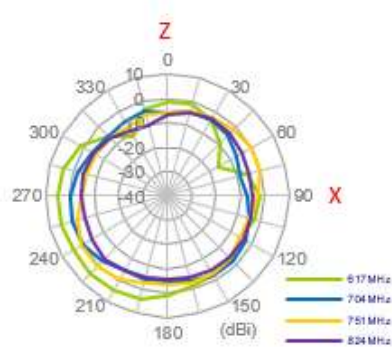
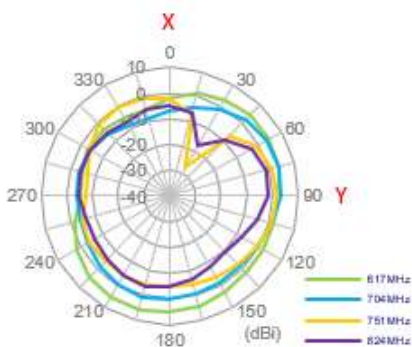

751MHz (MIMO2)

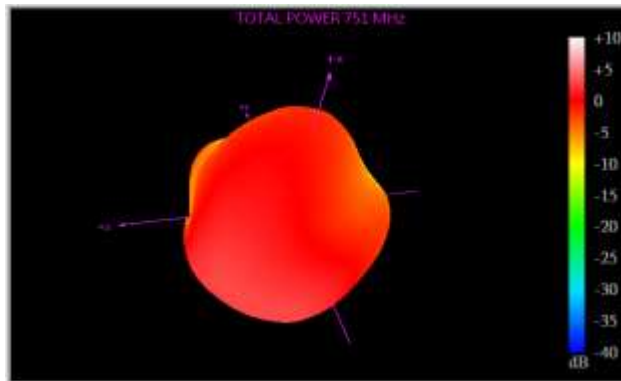

XY Plane

XZ Plane

YZ Plane

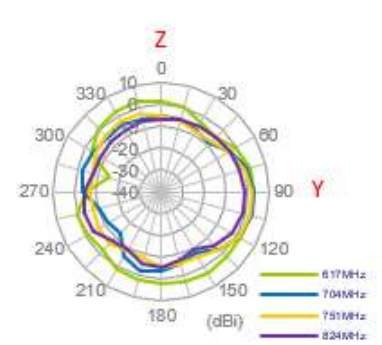
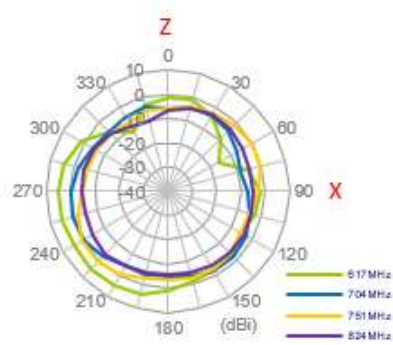
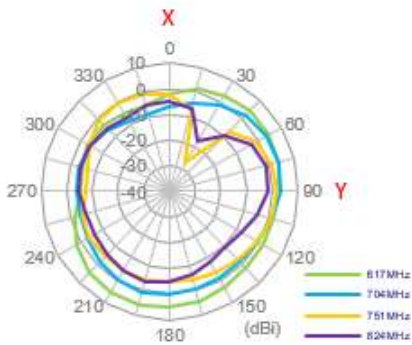

824MHz (MIMO2)

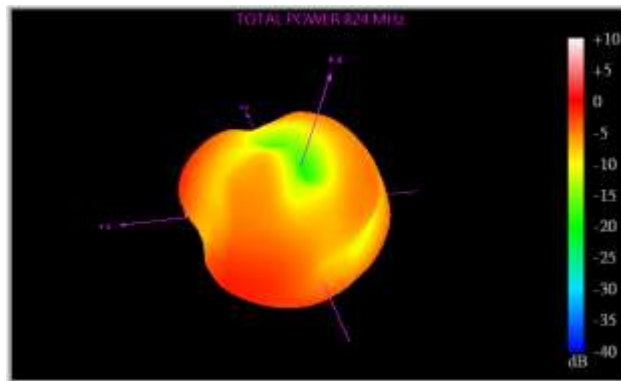

XY Plane

XZ Plane

YZ Plane

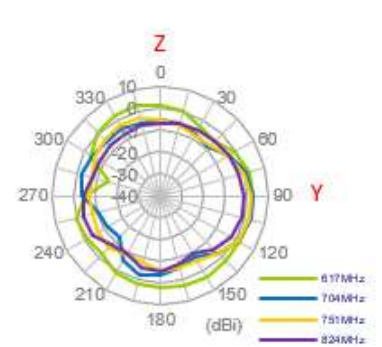
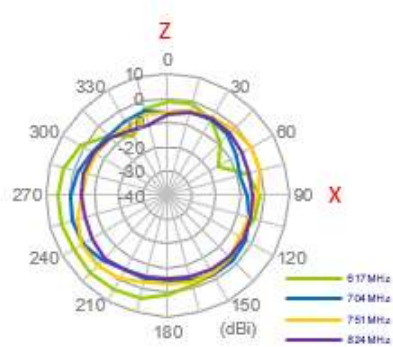
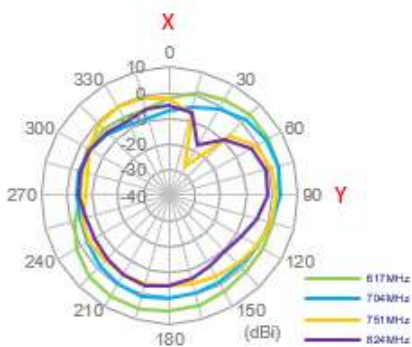

960MHz (MIMO2)

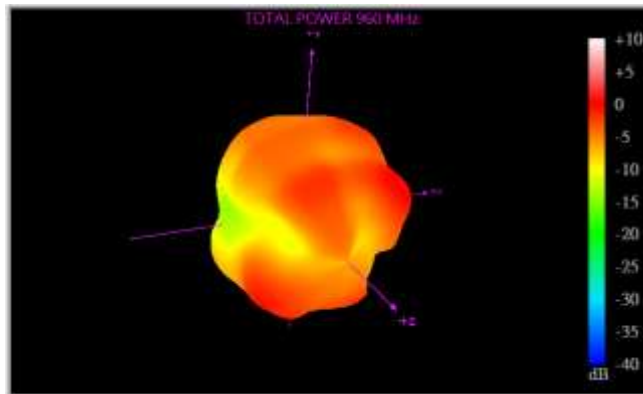

XY Plane

XZ Plane

YZ Plane

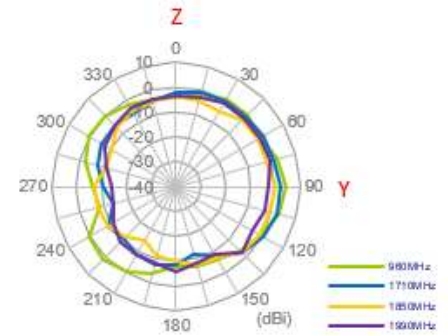
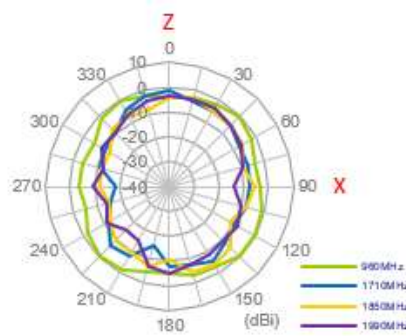
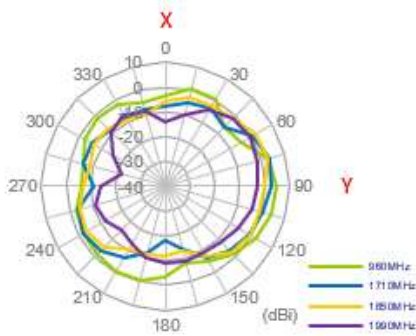

1710MHz (MIMO2)

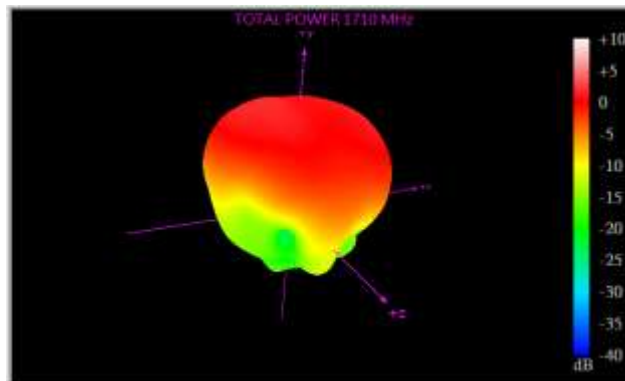

XY Plane

XZ Plane

YZ Plane

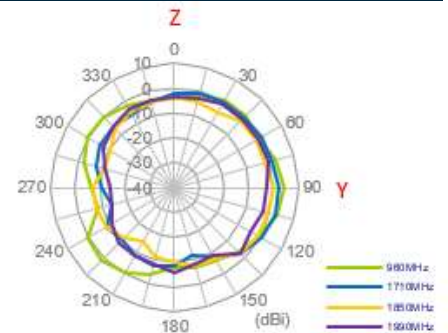
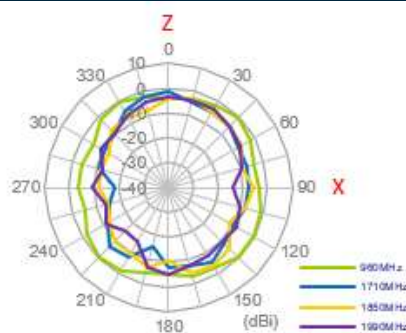
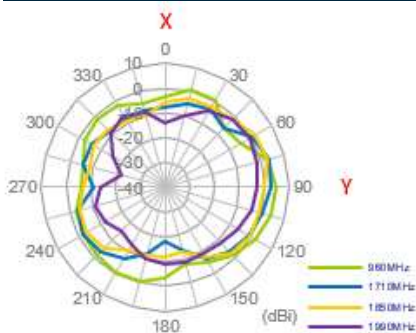

1850MHz (MIMO2)

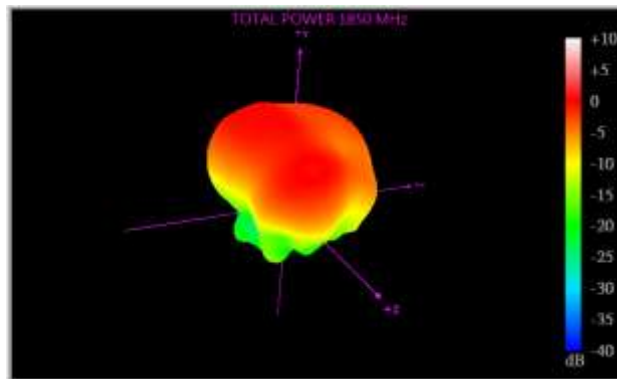

XY Plane

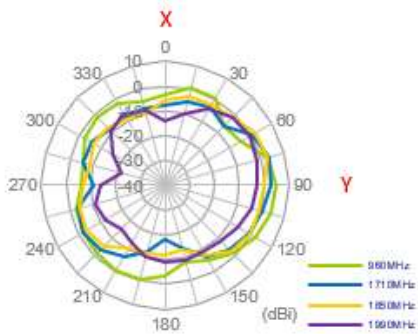

XZ Plane

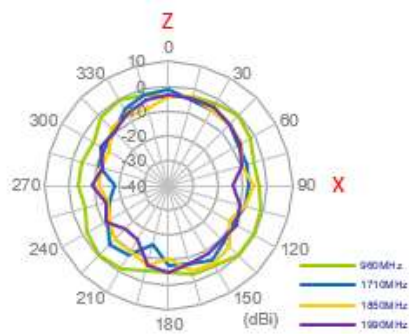

YZ Plane

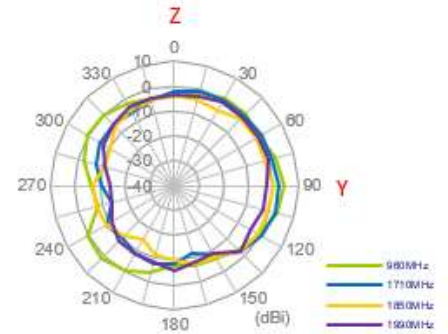

1990MHz (MIMO2)

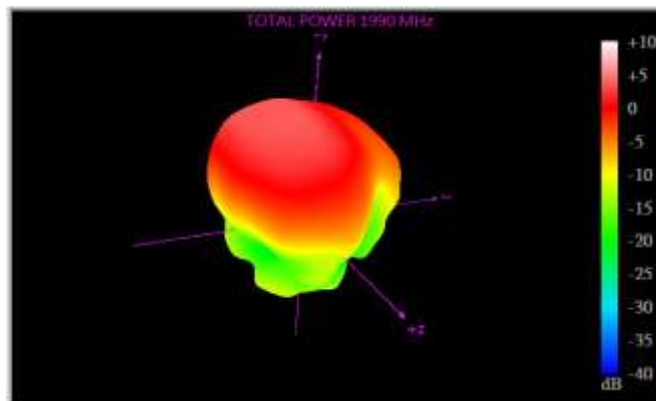

XY Plane

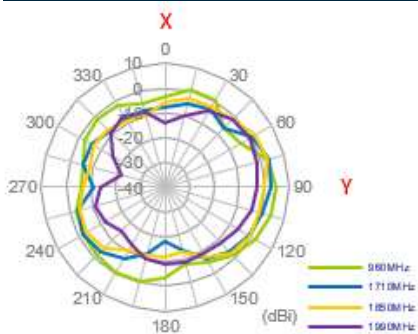

XZ Plane

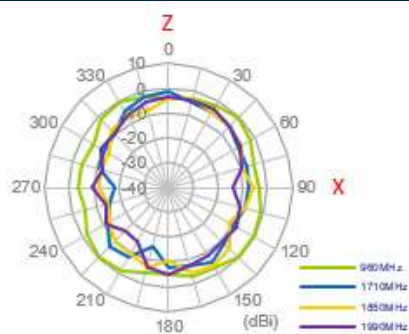

YZ Plane

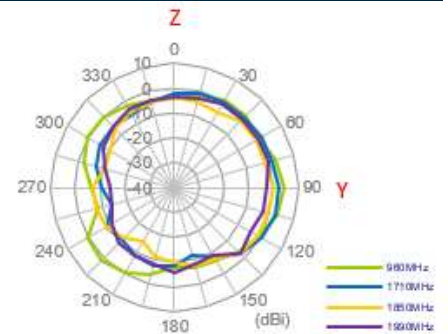

2170MHz (MIMO2)

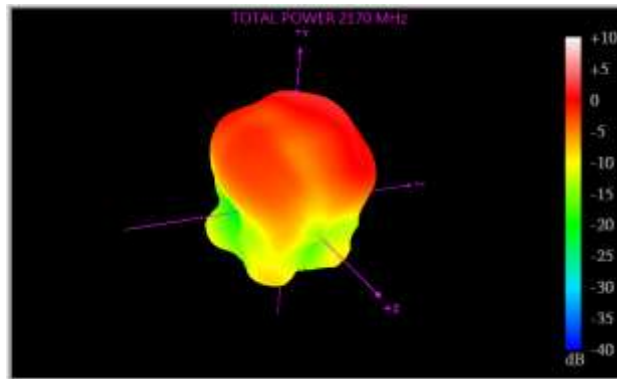

XY Plane

XZ Plane

YZ Plane

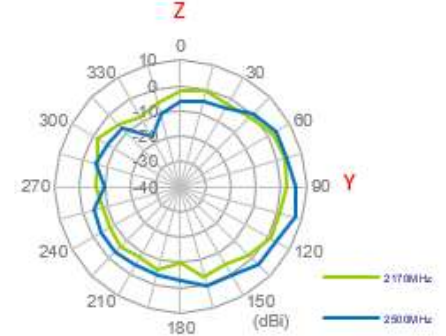
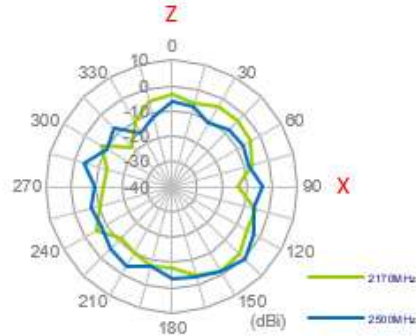
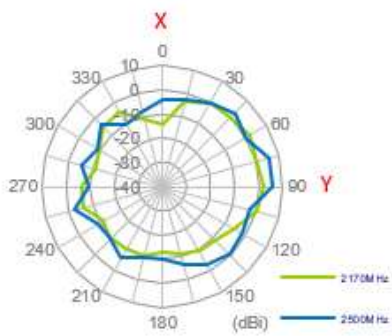

2500MHz (MIMO2)

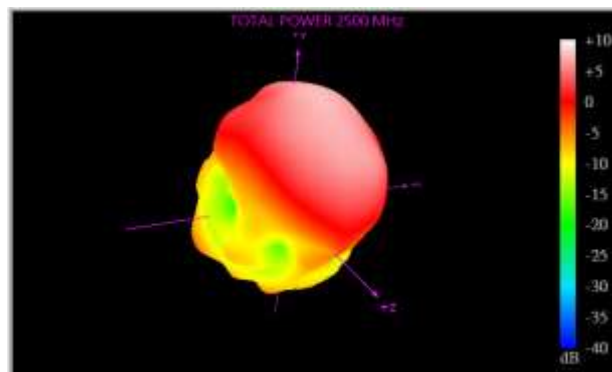

XY Plane

XZ Plane

YZ Plane

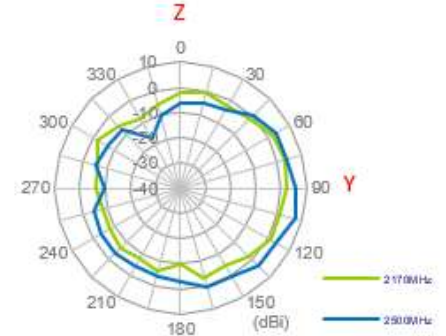
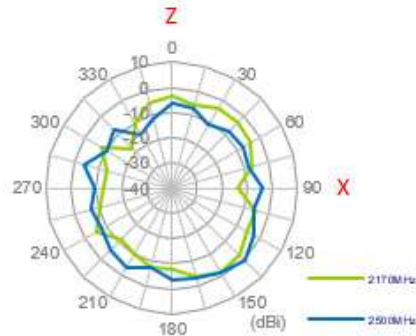
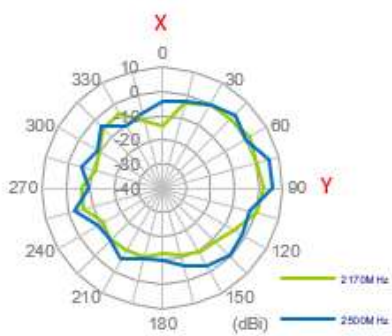

2690MHz (MIMO2)

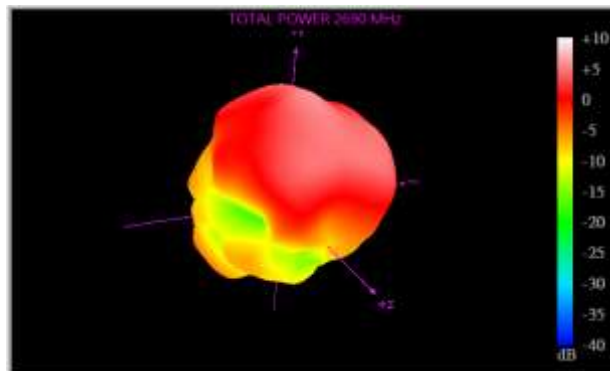

XY Plane

XZ Plane

YZ Plane

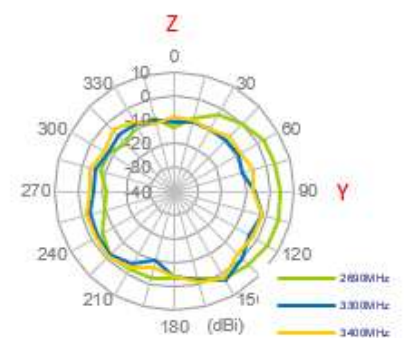
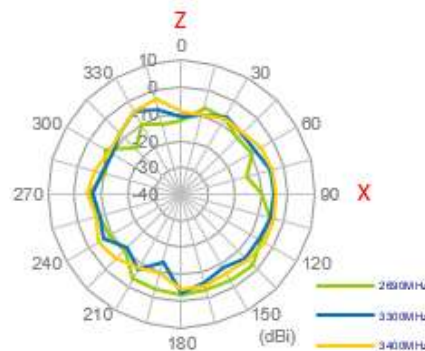
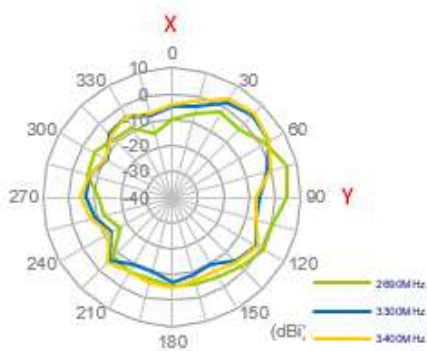

3300MHz (MIMO2)

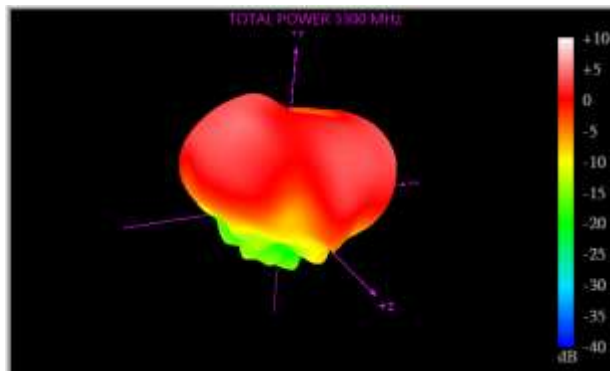

XY Plane

XZ Plane

YZ Plane

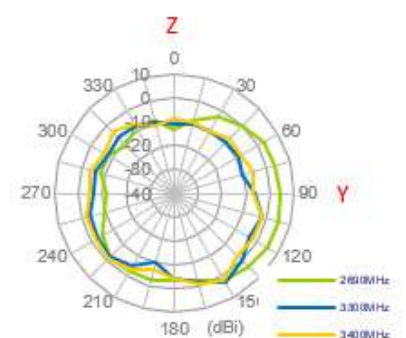
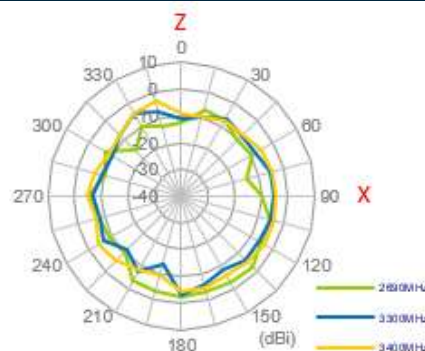
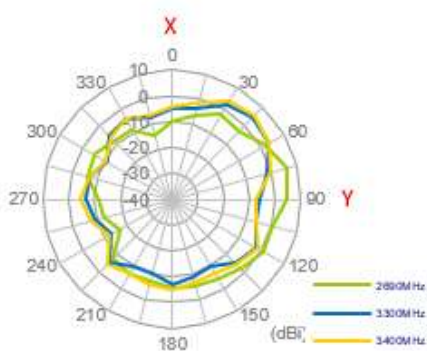

3400MHz (MIMO2)

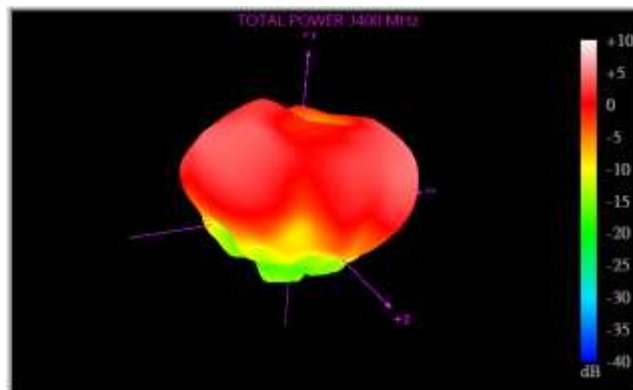

XY Plane

XZ Plane

YZ Plane

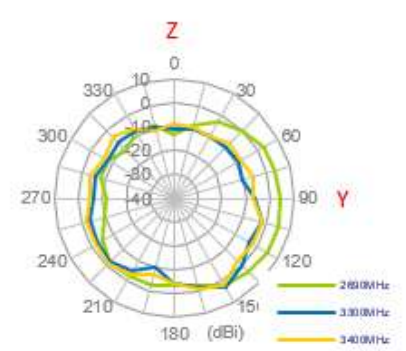
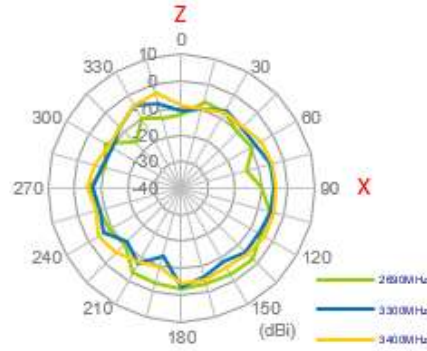
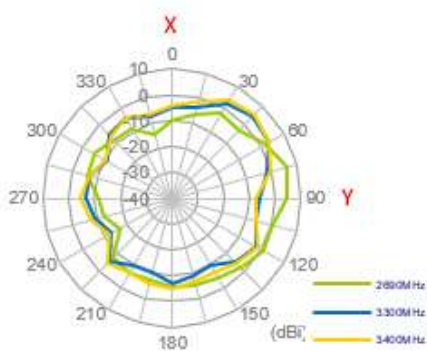

5150MHz (MIMO2)

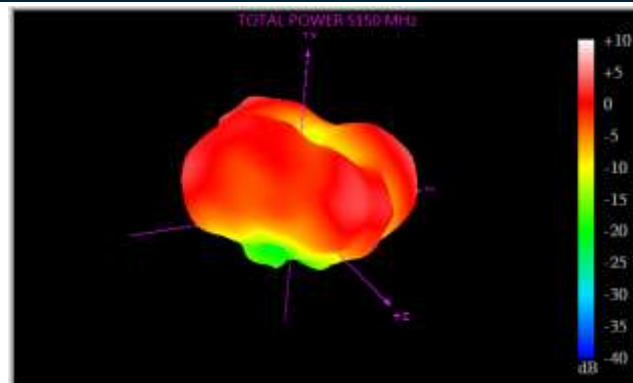

XY Plane

XZ Plane

YZ Plane

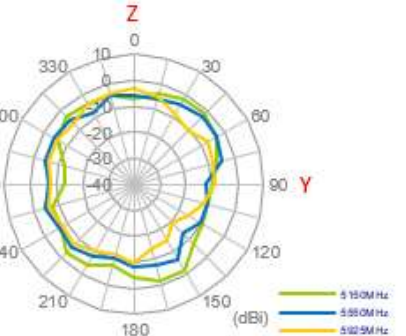
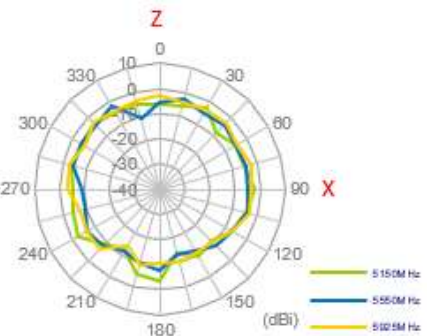
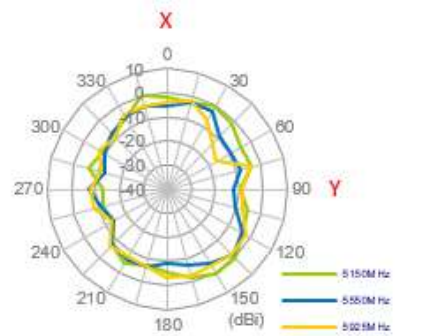

5550MHz (MIMO2)

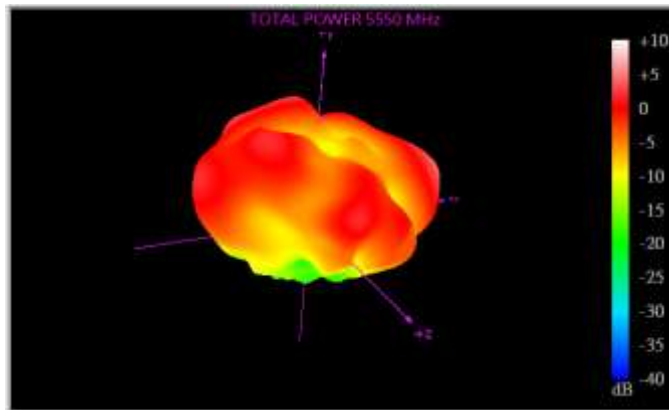

XY Plane

XZ Plane

YZ Plane

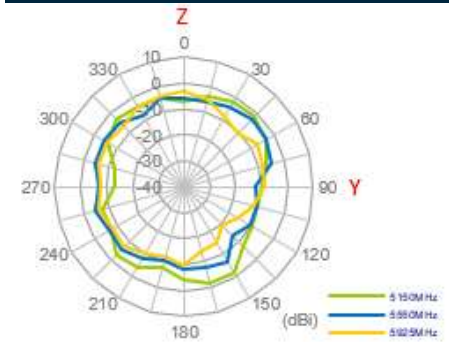
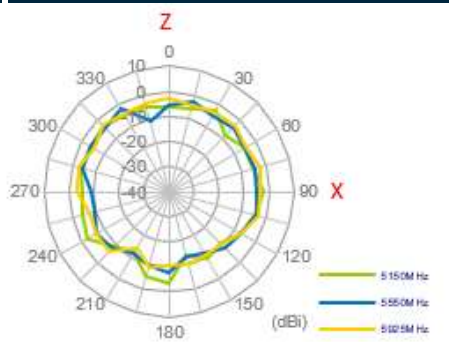
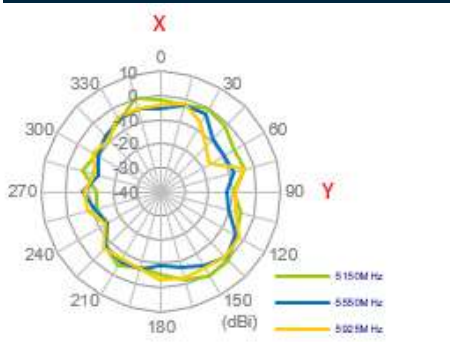

5925MHz (MIMO)

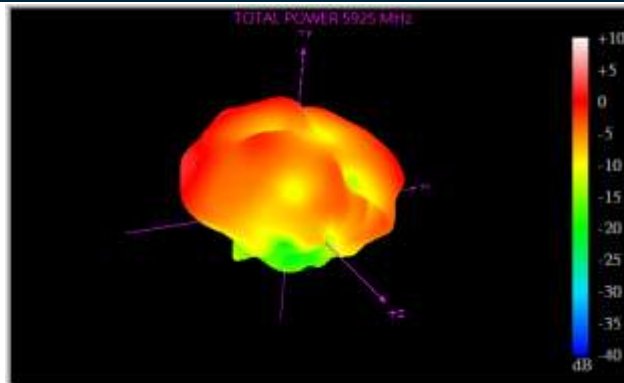

XY Plane

XZ Plane

YZ Plane

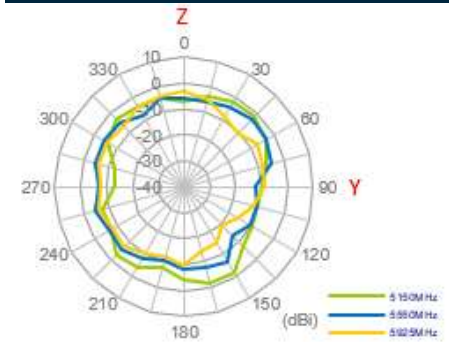
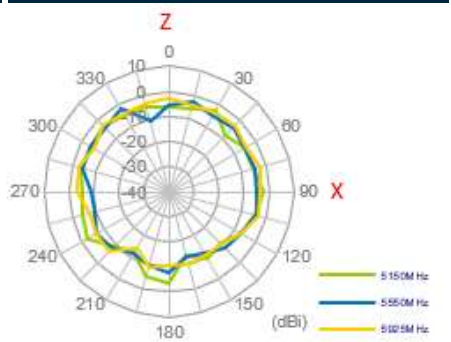
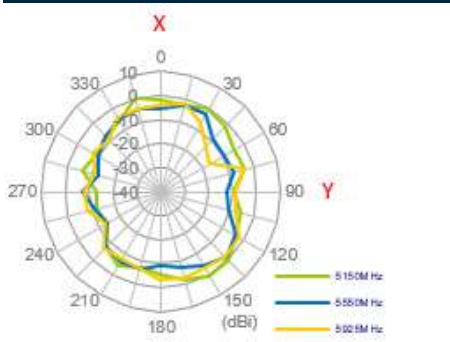

5. Mechanical Drawing (Units: mm)

Top View

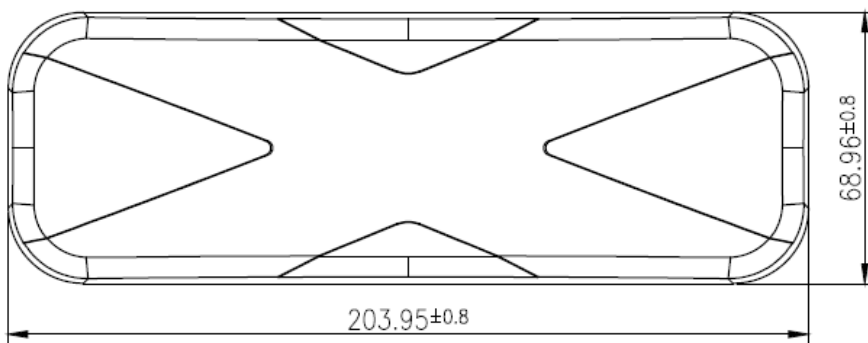

Bottom Thread View

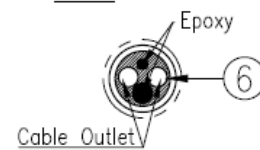

Front View

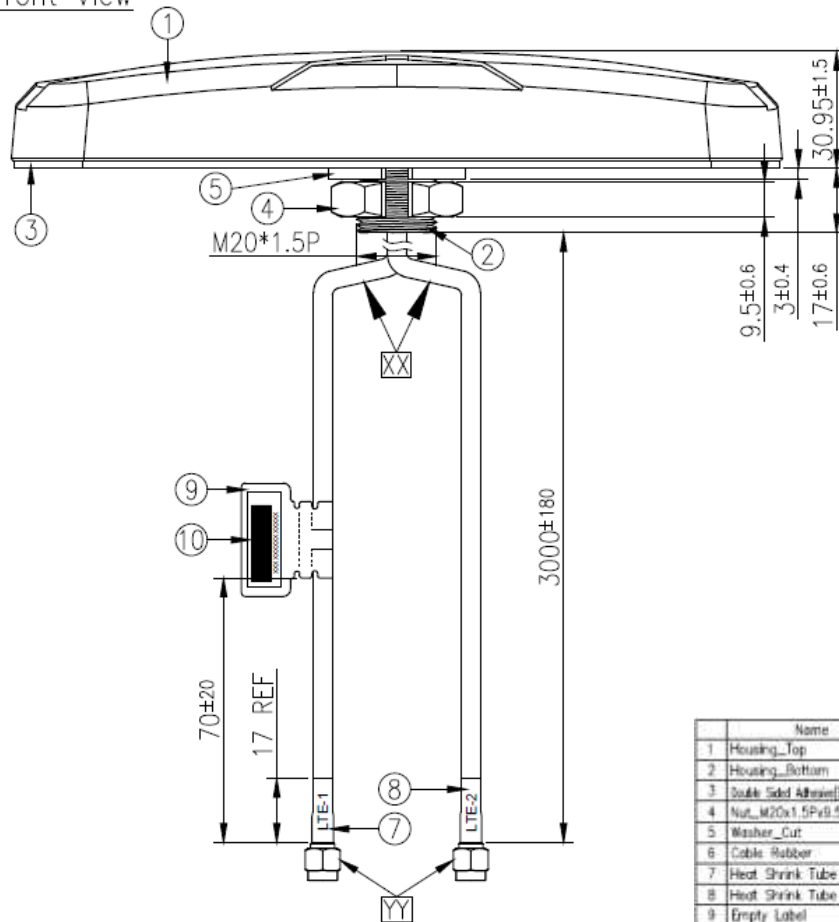

Name	P/N	Material	Finish	QTY
1 Housing_Top	000117810000A	ABS+PC	Black	1
2 Housing_Bottom	000117811000A	ABS+PC	Black	1
3 Double Sided Adhesive(Black Face)	0010178050000A	3M 9488K+CR130	White Liner	1
4 Nut_M20x1.5Px0.5H_Cut	000413030061A	Steel	Ni-Zn Plated	1
5 Washer_Cut	0004130340061A	Steel	Ni-Zn Plated	1
6 Cable_Rubber	0007130300063A	Silicone Rubber	Black	1
7 Heat Shrink Tube (LTE-1)	0013170020000A	PE	White Test/Red Tube	1
8 Heat Shrink Tube (LTE-2)	0013170030000A	PE	White Test/Red Tube	1
9 Empty Label	001015000000A	PEPA	White	1
10 Barcode Label	0010150010000A	PET	White	1

Name	P/N	SPEC	Finish	QTY
XX Cable Type	306718E00000A	TCC200	Black	2
YY Connector Type	200216D02009BA	SMA(M)ST	Au Plated	2

6. Packaging



16 pcs MA170.A.BI.001 per carton
 Carton Dimensions - 510*510*250mm
 Total Weight - 9.7kg

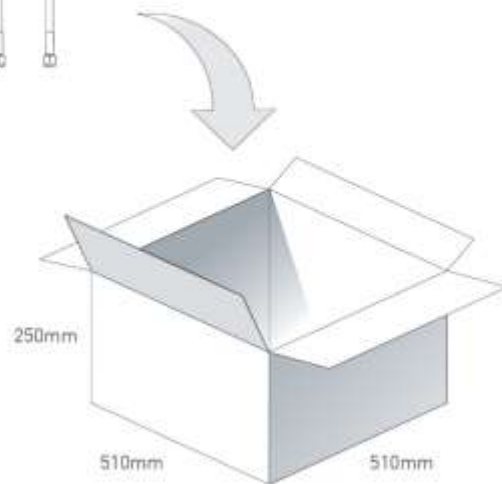

Carton top view

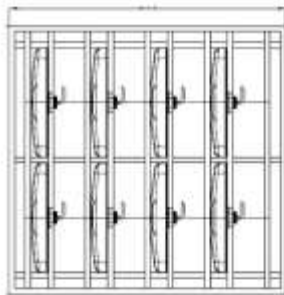

Carton side view

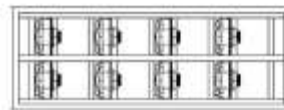

Pallet Dimensions 1200mm*1000mm*1450mm
 20 Cartons per pallet
 4 Cartons per layer
 5 Layers

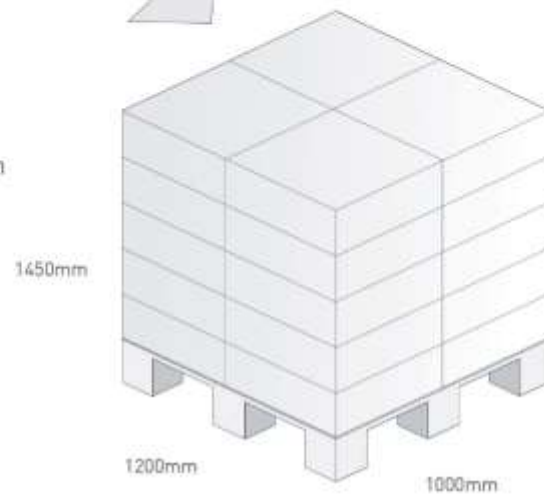

Changelog for the datasheet

SPE-17-8-088 - MA170.A.BI.001

Revision: E (Current Version)

Date:	2021-10-28
Notes:	Full datasheet update & added new data.
Author:	Gary West

Previous Revisions

Revision: D

Date:	2019-01-04
Notes:	Updated drawing
Author:	Jack Conroy

Revision: C

Date:	2018-09-25
Notes:	Updated drawing & cable type
Author:	Jack Conroy

Revision: B

Date:	2018-04-20
Notes:	New packaging spec
Author:	Carol Faughnan

Revision: A (Original First Release)

Date:	2017-11-28
Notes:	
Author:	Jack Conroy



TAOGLAS®

www.taoglas.com

