

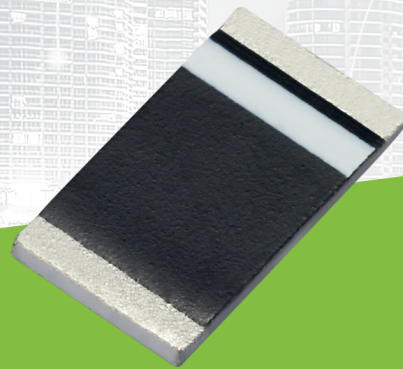

TAOGLAS®



Datasheet

ILA.09 915MHz 5*3*0.5mm -0.5dBi Ceramic Loop Antenna

Part No:

ILA.09

Description:

915MHz Embedded Ceramic Loop Antenna for ISM/Lora/LPWAN/Sigfox

Features:

- High Efficiency
- Omnidirectional
- Low profile
- Tiny Size
- Dims: 5.0*3.0*0.5mm
- Surface-Mount
- RoHS & REACH Compliant

1.	Introduction	3
2.	Specifications	4
3.	Antenna Characteristics	5
4.	Radiation Patterns	7
5.	Mechanical Drawing – Antenna	9
6.	Mechanical Drawing – Evaluation Board	11
7.	Soldering Conditions	12
8.	Packaging	13
9.	Changelog	15

Taoglas makes no warranties based on the accuracy or completeness of the contents of this document and reserves the right to make changes to specifications and product descriptions at any time without notice. Taoglas reserves all rights to this document and the information contained herein. Reproduction, use or disclosure to third parties without express permission is strictly prohibited.



1. Introduction

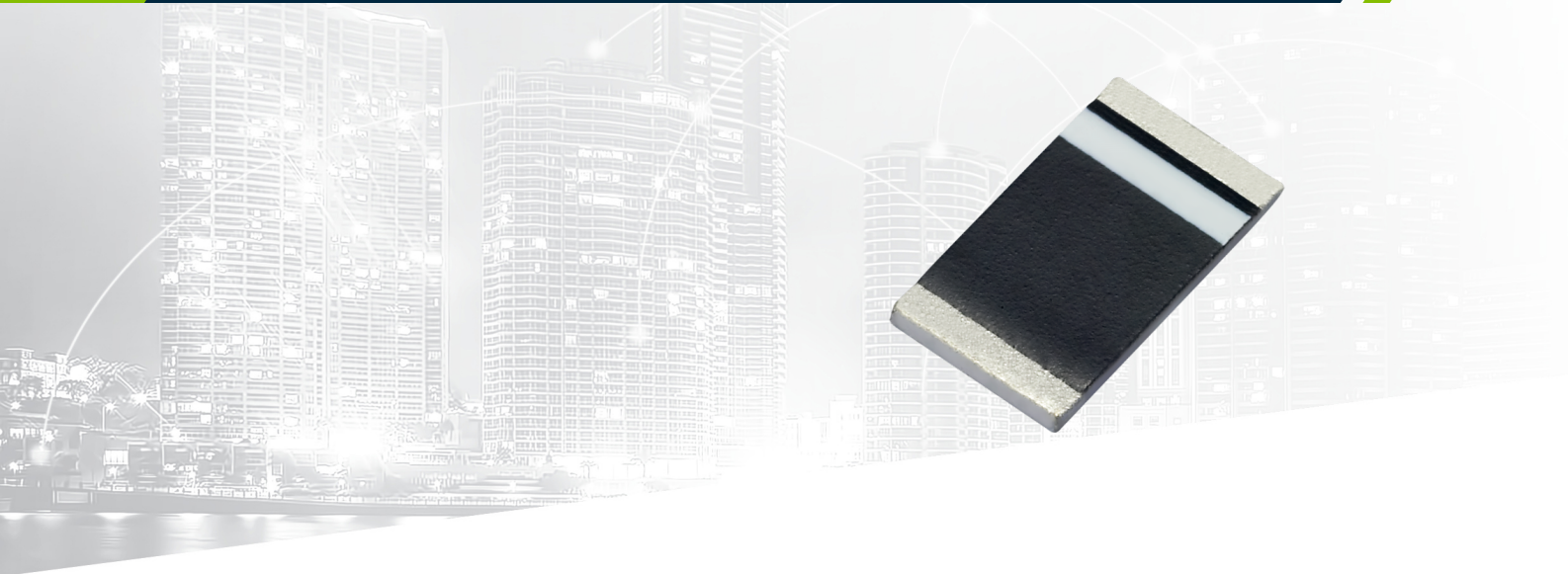

The ILA.09 is a new 915MHz ISM band embedded ceramic loop antenna from Taoglas featuring good efficiency of 55% at the center of the band. It is the perfect solution for the growing number of devices using the 915MHz band such as Sigfox and LoRa applications in the US, or in metering application.

This antenna works best when placed at the center of the board edge. The ILA.09 antenna, at 5*3*0.5mm, is low profile and would be suitable for devices with space constraints. The ILA.09 is delivered on tape and reel and now allows M2M customers to use an omnidirectional SMT antenna. The omnidirectional radiation characteristics allow for excellent performance regardless of device orientation. This is especially useful for devices that are not fixed in one particular spot during use. When there is little PCB space available for antenna placement, but high performance is required, the ILA.09 is the ideal choice.

The antenna is manufactured in a TS16949 first tier automotive approved facility and has passed the most stringent reliability testing. Since it is SMD, it is much easier to integrate and more reliable in high volume production compared to helical antennas which are cumbersome to install and subject to variability due to the need for manual assembly.

For further optimization to customer-specific device environments and for support to integrate and test this antennas performance in your device, contact your regional Taoglas Customer Services Team.

Applications:

- Sigfox
- Lora
- LPWAN
- Automated Meter Reading (AMR)
- Radio Frequency Identification (RFID)
- Remote Monitoring
- Healthcare
- Sensing
- Alarm Systems
- Handheld Devices

2. Specifications

Antenna			
Frequency (MHz)	902	915	928
Efficiency (%)			
80 x 40 mm Ground Plane	25.66	55.93	34.45
Peak Gain (dBi)			
80 x 40 mm Ground Plane	-3.00 dBi	0.39 dBi	-1.78 dBi
Max Return Loss (dB)	< -3	< -10	< -3
Impedance (Ω)	50 Ω		
Polarization	Linear		
Input Power(W)	2		
Mechanical			
Dimensions (mm)	5.0 x 3.0 x 0.5		
Ground plane (mm)	80 x 40		
Weight (g)	0.02		
Environmental			
Temperature Range	-40°C to 85°C		
Storage Temperature	-40°C to 85°C		
Humidity	20% to 70%		
Moisture Sensitivity Level	3 (168 Hours)		

3. Antenna Characteristics

3.1 Return Loss

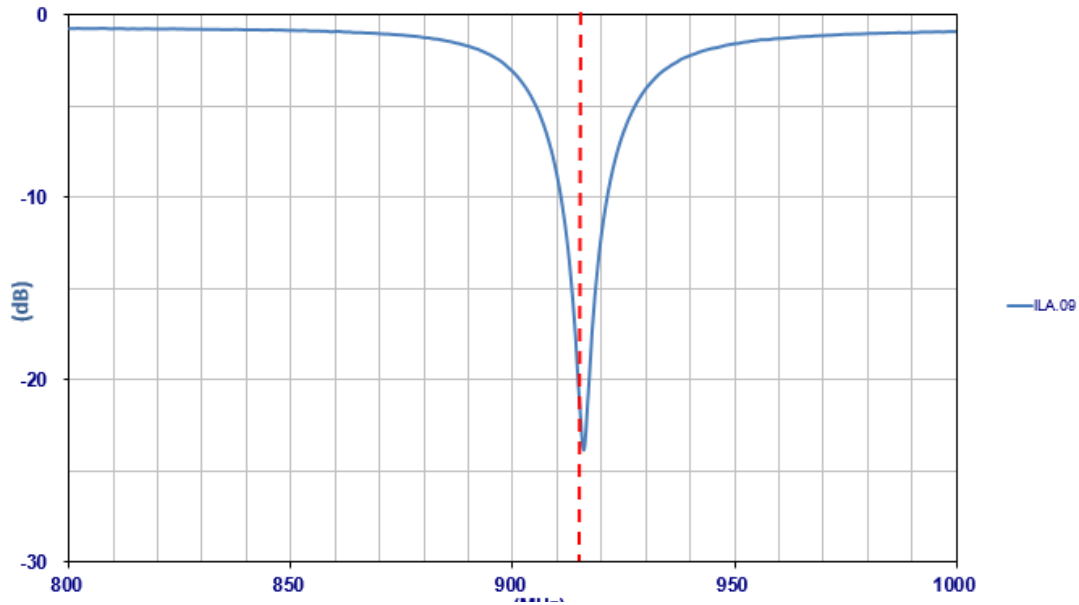

3.2 Efficiency

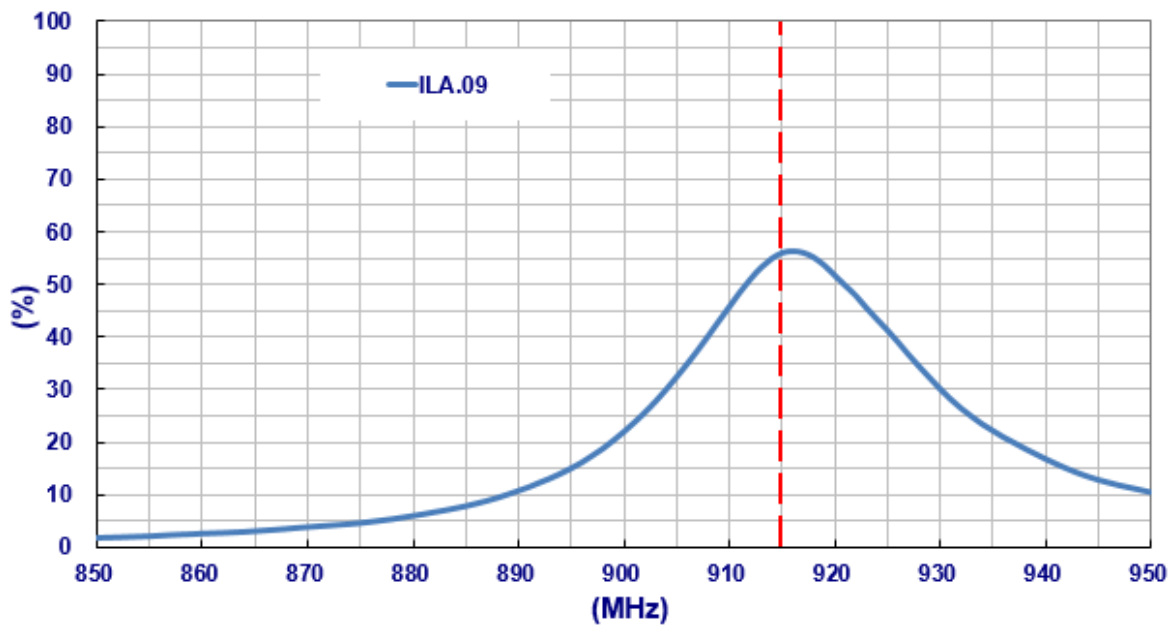

3.3 Average Gain

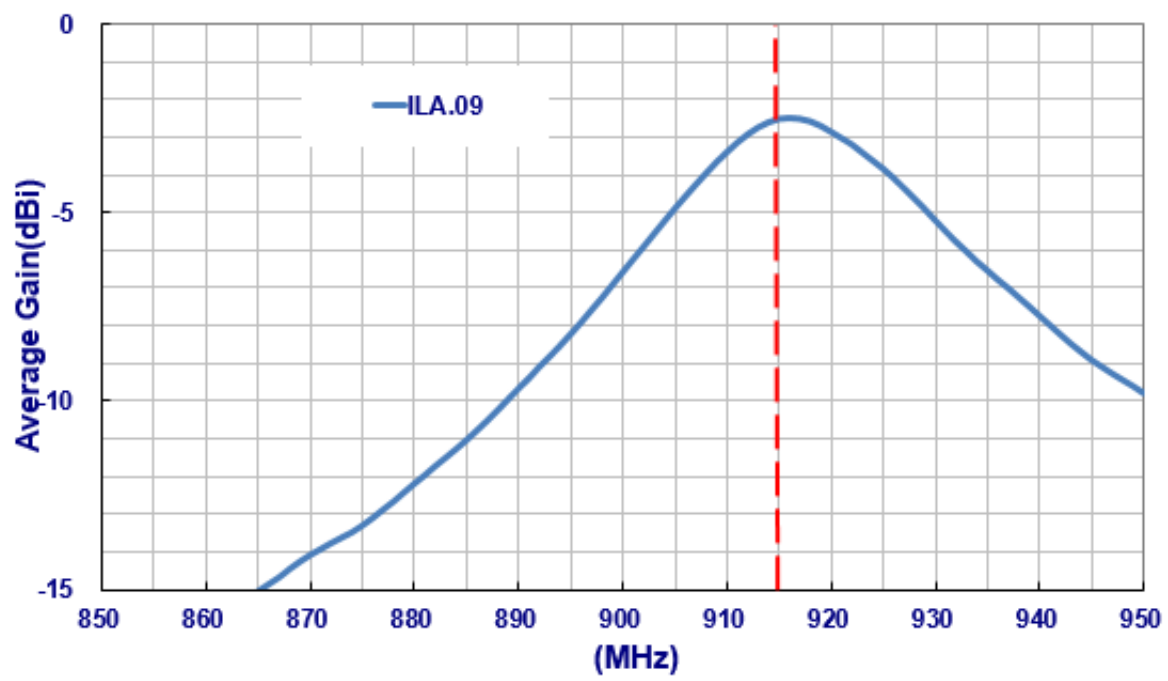

3.4 Peak Gain

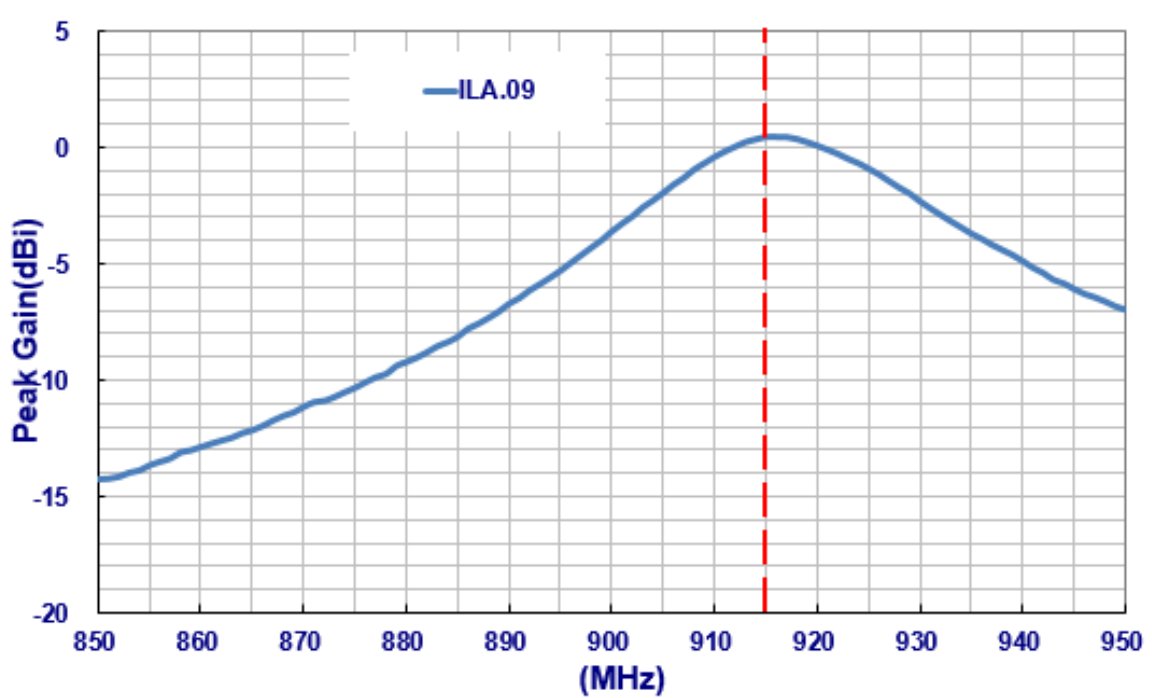

4. Radiation Patterns

4.1 Test Setup – Antenna on Evaluation Board



4.2 2D Radiation Pattern

915 MHz

XY Plane

XZ Plane

YZ Plane

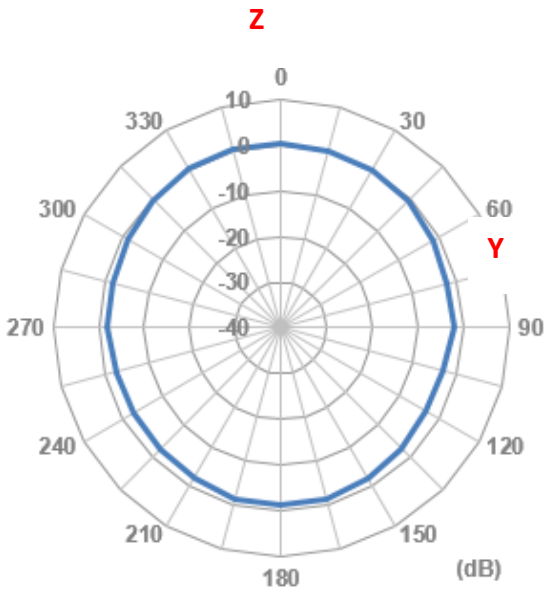
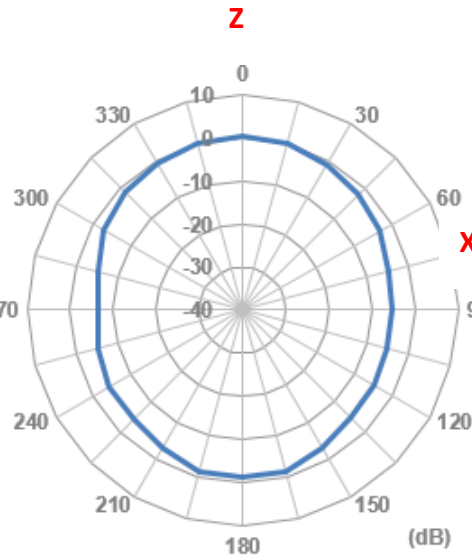
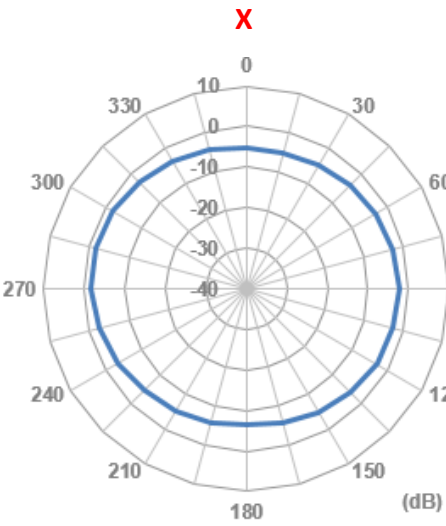

4.3 3D Radiation Pattern

915 MHz

Azimuth = 121.0
Elevation = -35.9
Roll = -44.8

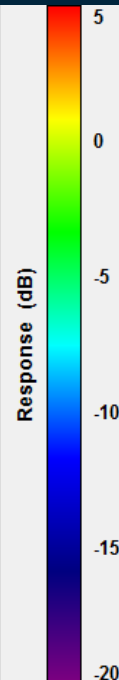
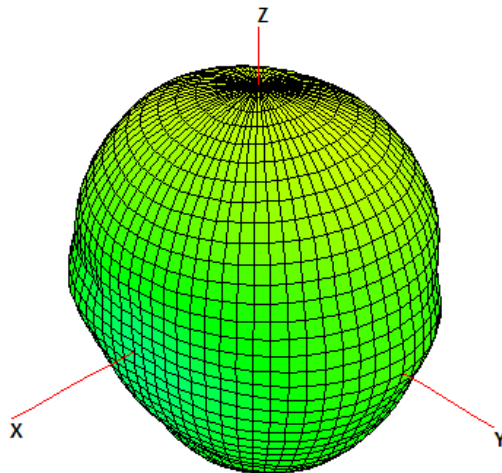

5. Mechanical Drawing – Antenna

5.1 Antenna Dimension and Drawing

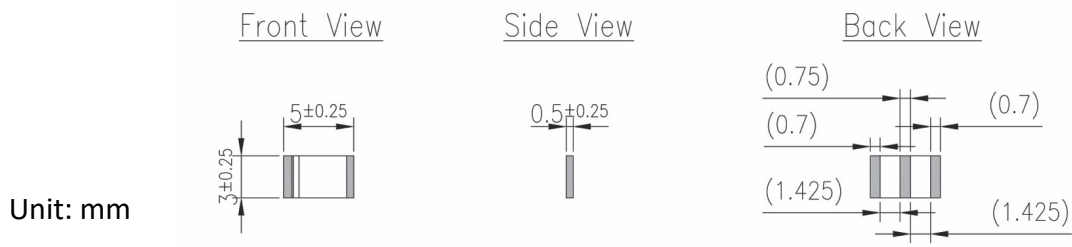

5.2 Antenna Footprint

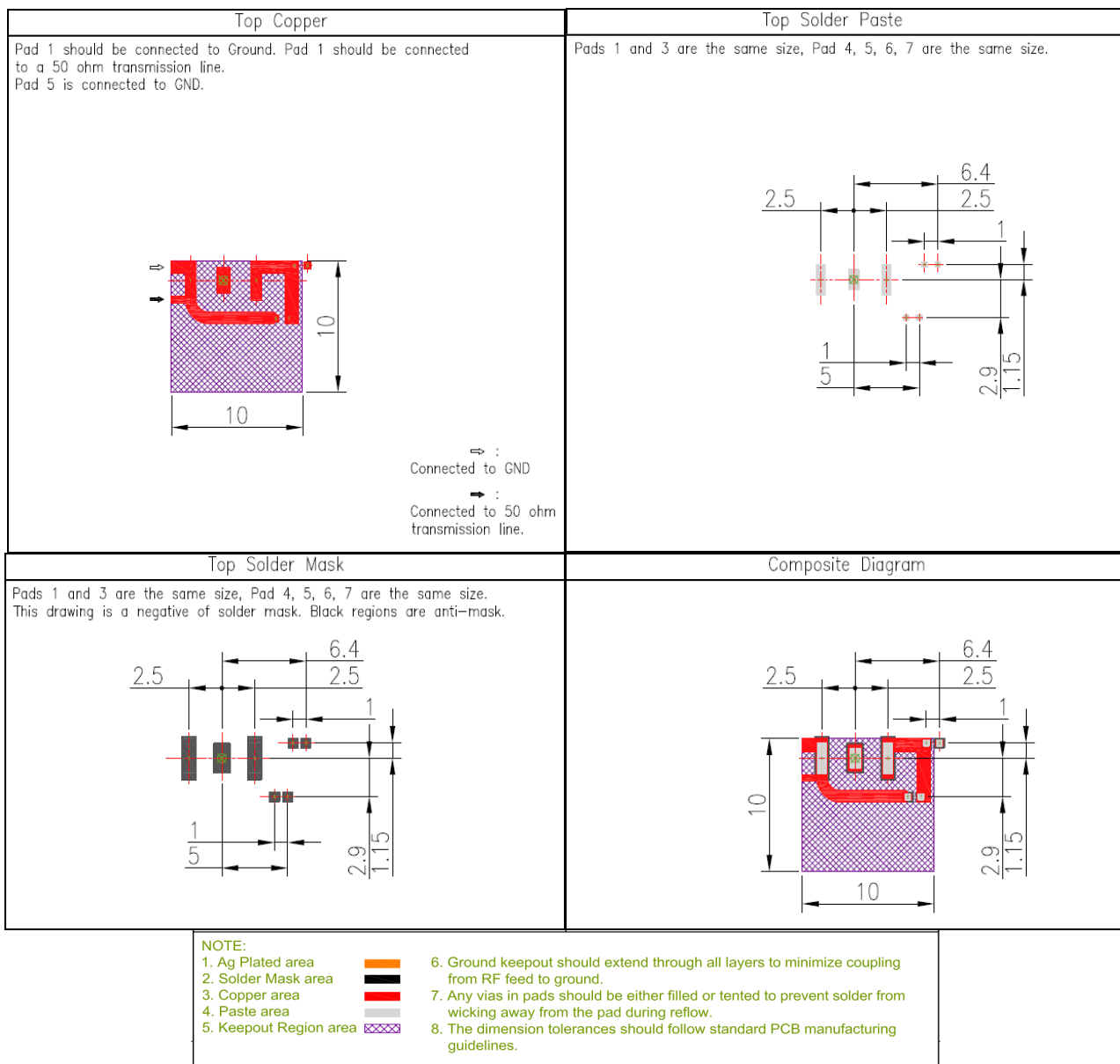

*Taoglas is able to provide CAD drawing file to customers for evaluation.

5.2 Matching Circuit

Like all antennas, surrounding components, enclosures, and changes to the GND plane dimensions can alter performance. A pi-matching network like the one shown below is required incase adjustments need to be made. The antenna EVB has the same matching network. The components on the EVB are a good starting point for a new design, but will need to be adjusted upon integration for best performance. The zero ohm resistor is needed to solder down a coax pigtail to make measurements with a vector network analyzer.

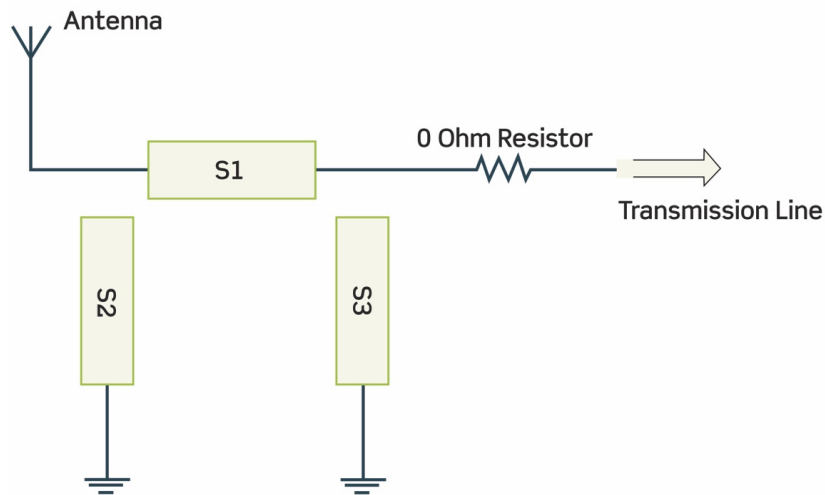

6. Mechanical Drawing – Evaluation Board

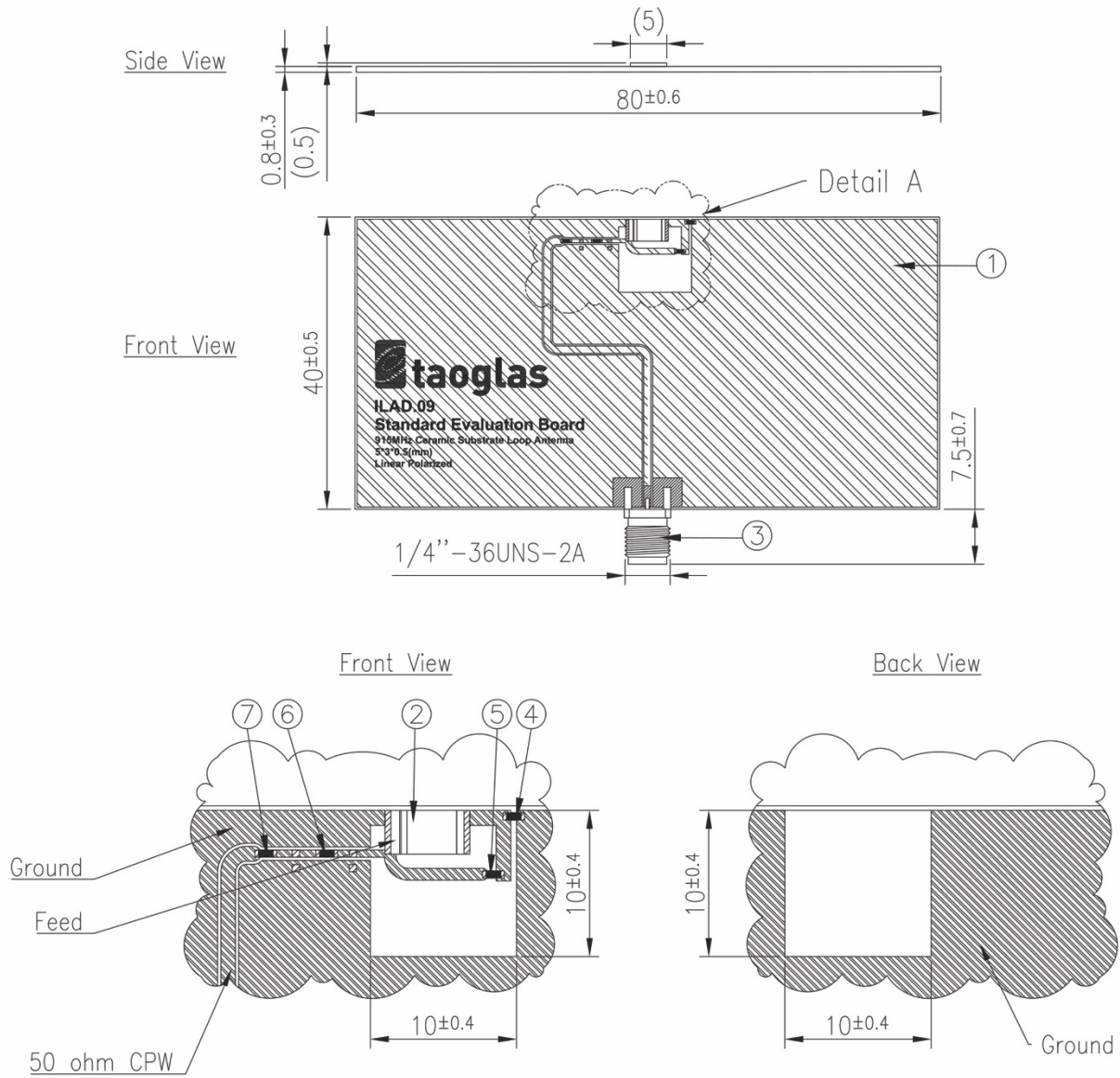

	Name	Material	Finish	QTY
1	ILAD.09 EVB Board	Composite	Black	1
2	ILA.09 Chip Antenna	Ceramic	N/A	1
3	SMA(F) ST	Brass	Au Plated	1
4	Capacitor 3.9pF (0402)	Ceramic	N/A	1
5	Capacitor 2.2pF (0402)	Ceramic	N/A	1
6	Inductor 1.8nH (0402)	Ceramic	N/A	1
7	Capacitor 22pF (0402)	Ceramic	N/A	1

7. Soldering Conditions

Typical Soldering profile for lead-free process:

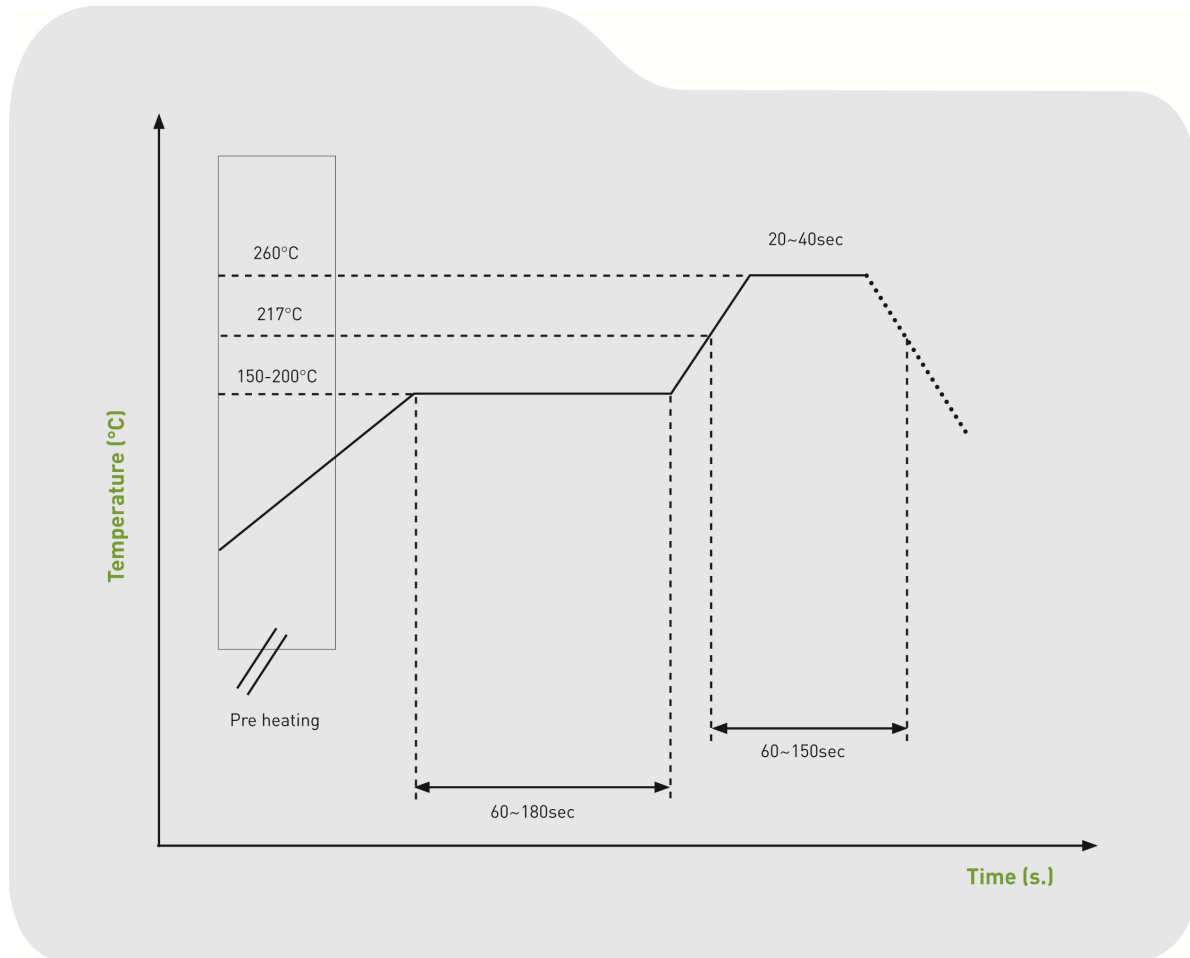

9. Packaging

6000 pcs ILA.09 per tape & reel
 Dimensions - 330*330*17mm
 Weight - 680g

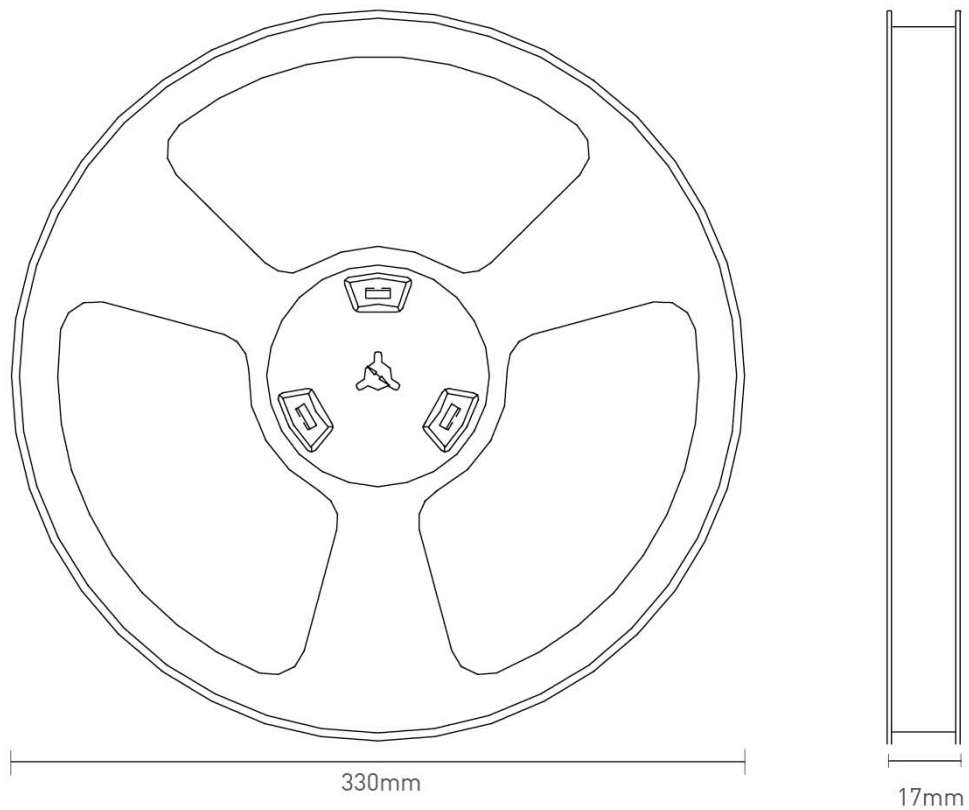

Tape Dimensions (unit: mm)		
Feature	Spec	Tolerances
W	12.00	±0.30
P	4.00	±0.10
E	1.75	±0.10
F	5.50	±0.10
P2	2.00	±0.10
D	1.50	+0.10 -0.00
Po	4.00	±0.10
10Po	40.00	±0.10

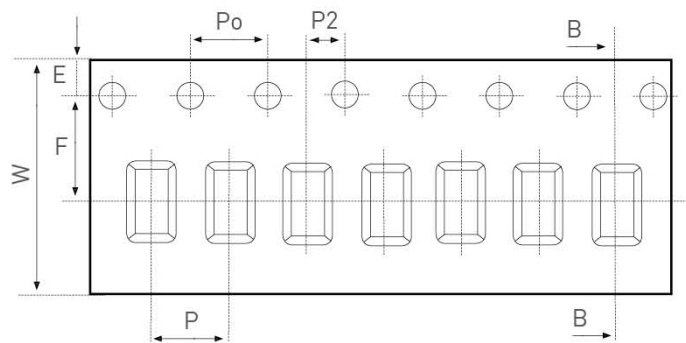

6000 pcs ILA.09
 1 reel in small inner box
 Dimensions - 330*330*17
 Weight - 680g

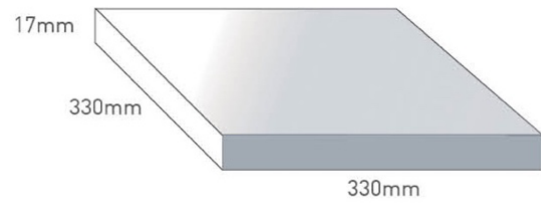

9 boxes / 54000 pcs in one carton
 Carton Dimensions - 350*350*210mm
 Weight - 6.69Kg

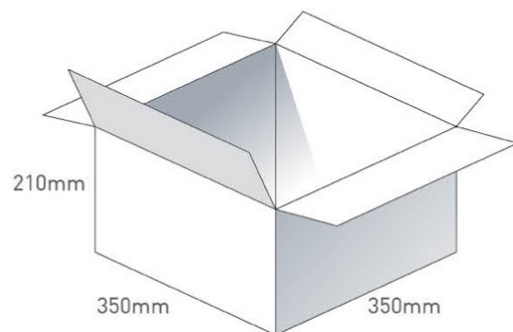

Pallet Dimensions 1220*1020*1410mm
 36 Cartons per Pallet
 4 Cartons per layer
 9 Layers

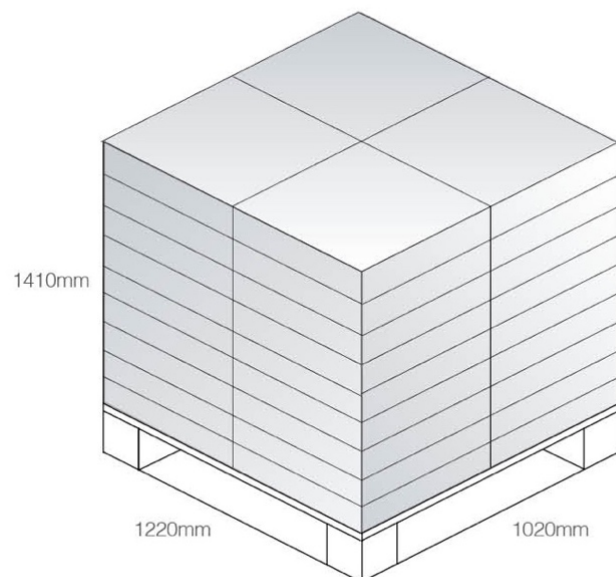

Changelog for the datasheet

SPE-16-8-051 – ILA.09

Revision: B (Current Version)

Date:	2021-10-31
Changes:	Format Change, MSL
Changes Made by:	Erik Landi

Previous Revisions

Revision: A (Original First Release)

Date:	2016-05-17
Notes:	Initial Release
Author:	STAFF



TAOGLAS®

www.taoglas.com

