

Microcontrollers

2021

America

Epson America, Inc.
Headquarter:
3131 Katella Ave., Los Alamitos, CA 90720, USA
Phone: +1-562-290-4677

San Jose Office:
214 Devcon Drive
San Jose, CA 95112 USA
Phone: +1-800-228-3964 or +1-408-922-0200

Europe

Epson Europe Electronics GmbH
Riesstrasse 15, 80992 Munich, Germany
Phone: +49-89-14005-0 FAX: +49-89-14005-110

Asia

Epson (China) Co., Ltd.
4th Floor, Tower 1 of China Central Place, 81 Jianguo Road, Chaoyang District, Beijing 100025 China
Phone: +86-10-8522-1199 FAX: +86-10-8522-1120

Shanghai Branch
Room 1701 & 1704, 17 Floor, Greenland Center II, 562 Dong An Road, Xu Hui District, Shanghai, China
Phone: +86-21-5330-4888 FAX: +86-21-5423-4677

Shenzhen Branch
Room 804-805, 8 Floor, Tower 2, Ali Center, No.3331 Keyuan South RD(Shenzhen bay), Nanshan District, Shenzhen 518054, China
Phone: +86-10-3299-0588 FAX: +86-10-3299-0560

Epson Taiwan Technology & Trading Ltd.
15F., No. 100, Songren Rd., Sinyi Dist., Taipei City 110. Taiwan
Phone: +886-2-8786-6688

Epson Singapore Pte., Ltd.
438B Alexandra Road, Block B Alexandra TechnoPark, #04-01/04, Singapore 119968
Phone: +65-6586-5500 FAX: +65-6271-7066

Epson Korea Co., Ltd.
10F Posco Tower Yeoksam, Teheranro 134 Gangnam-gu, Seoul, 06235, Korea
Phone: +82-2-3420-6695

Seiko Epson Corp. Sales & Marketing Division

Device Sales & Marketing Department
29th Floor, JR Shinjuku Miraina Tower, 4-1-6 Shinjuku, Shinjuku-ku, Tokyo 160-8801, Japan

Business Concept

Expanding use of smartphones and tablets is giving broadband internet and wireless communications even greater roles in our daily lives, and making the arrival of the ubiquitous network society an inevitable reality. In particular, semiconductors for use in portable devices, information terminals, in-vehicle devices and FA devices are expected to provide higher performance in terms of thinner structure, lighter weight, and longer operation with limited power supply. We have been focusing on the creation of compact, low-power semiconductors since we started the development of CMOS LSI for watches in 1969. Since then, we have steadily built up our expertise in energy-saving, space-saving, and time-saving designs. This has enabled us to quickly obtain the semiconductor development technology needed to meet the demands of the new era of ubiquitous networks. Our concept is to develop "saving technologies" to reduce power consumption, development times, and implementation space. Our goal is to be a true partner for you, providing you with strategic advantages, enhancing your customer value based on our "saving technologies" and mixed analog/digital technologies that we have cultivated, as well as our design capabilities, manufacturing capabilities and stable supply that can satisfy your detailed requirements.

Environmental Responsibility

Epson semiconductor technology provides environmental value to customers by creating and manufacturing eco-friendly products.

- 1) We Epson's products are surely complying with the Eu-RoHS (2011/65/EU) Directive.
- 2) We are releasing information about the containing chemical substances of products at web-site. Product of QFP & BGA are described in the following URL.
global.epson.com/products_and_drivers/semicon/information/package_lineup.html *Some products are excluded.

Environmental management system third party certification status ISO14001

Type of certification : ISO 14001: 2015, JIS Q 14001: 2015
 Awarded to : TOHOKU EPSON CORPORATION, SEIKO EPSON CORPORATION
 (Fujimi Plant, Suwa Minami Plant)

Certified by : Bureau Veritas Japan Co., Ltd.
 Date of certification : April 3, 1999

Type of certification : ISO 14001: 2015
 Awarded to : Singapore Epson Industrial Pte. Ltd.
 Certified by : SGS
 Date of certification : Jan 12, 1999



Epson's Quality Policy

Keeping the customer in mind at all times, we make the quality of our products and services our highest priority. From the quality-assurance efforts of each employee to the quality of our company as a whole, we devote ourselves to creating products and services that please our customers and earn their trust. Epson has acquired ISO9001 and IATF16949 certification with its IC, module and their application products.

Quality Management system third party certification status ISO9001

Type of Certification : ISO9001: 2015 , JIS Q 9001: 2015
 Awarded to : TOHOKU EPSON CORPORATION, SEIKO EPSON CORPORATION
 (Fujimi Plant, Suwa Minami Plant, Tokyo Office)

Certified by : Bureau Veritas Japan Co., Ltd.
 Certificate No. : 3762381
 Initial Date of Certification : October 10, 1993

Type of Certification : ISO9001: 2015
 Awarded to : Singapore Epson Industrial Pte. Ltd.
 Certified by : SGS
 Certificate No. : SG03/00011
 Initial Date of Certification : February 4, 2003



IATF16949

Type of Certification : IATF16949:2016
 Awarded to : TOHOKU EPSON CORPORATION, SEIKO EPSON CORPORATION
 (Fujimi Plant, Suwa Minami Plant, Tokyo Office), Epson Europe Electronics GmbH, Epson America, Inc., Epson Canada Ltd.(Vancouver Design Center)

Certified by : Bureau Veritas Japan Co., Ltd.
 Certificate No. : 281371
 Initial Date of Certification : Dec 9, 2017

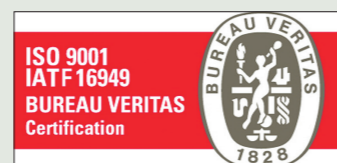

Type of Certification : IATF16949:2016
 Awarded to : Singapore Epson Industrial Pte. Ltd.
 Certified by : SGS
 Certificate No. : SG07/00021
 Initial Date of Certification : May 2, 2018

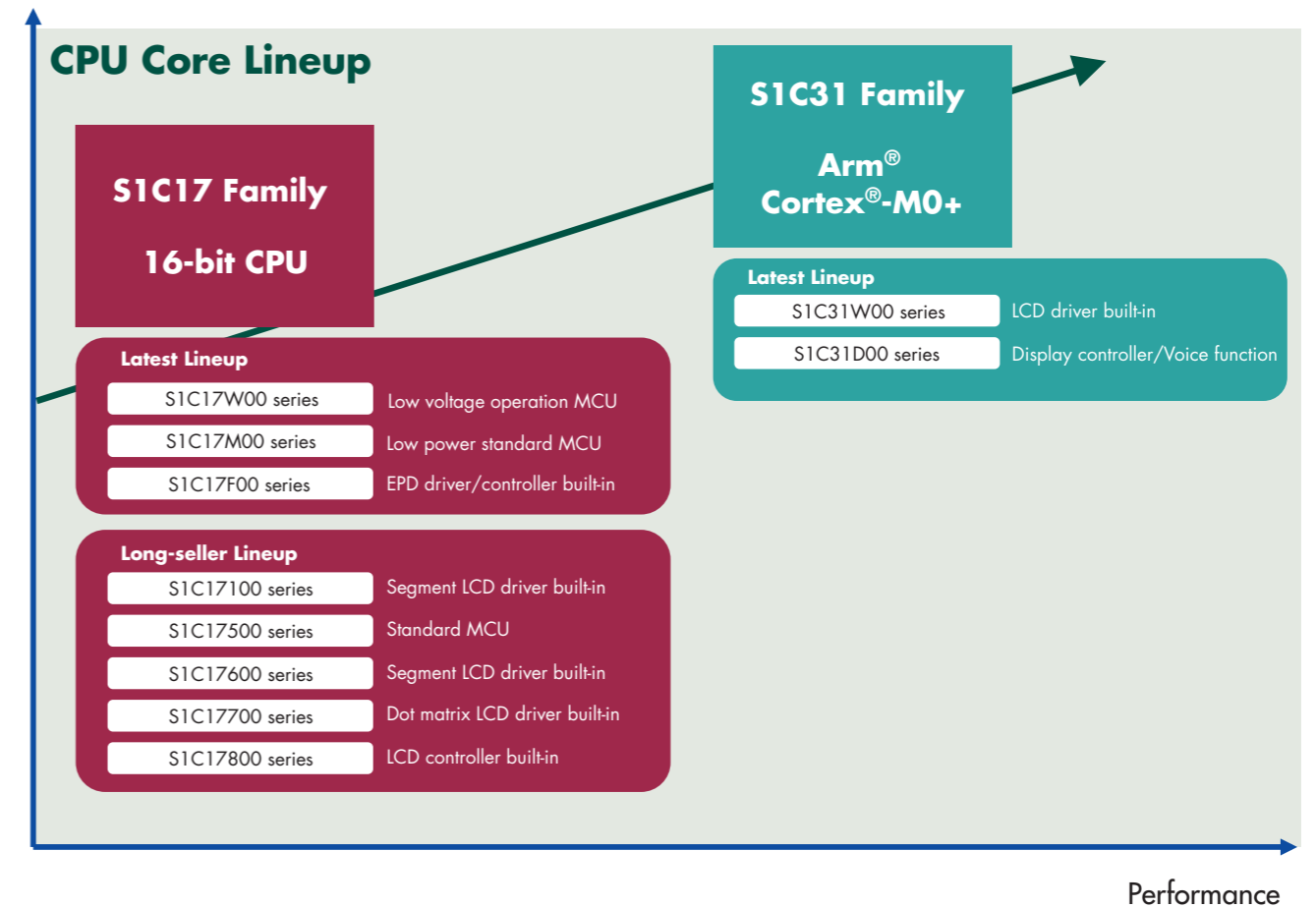

C O N T E N T S

History of Epson semiconductor	4-5	Epson MCU website	20-21
Epson microcontroller overview	6	Development environments	22-25
Features of Epson microcontrollers	7-9	Flash memory writing	26-27
S1C31 Family Arm® microcontrollers	10-13	Package lineup	28-29
S1C17 Family 16-bit microcontrollers	14-19		

Value Generated by Epson Technologies

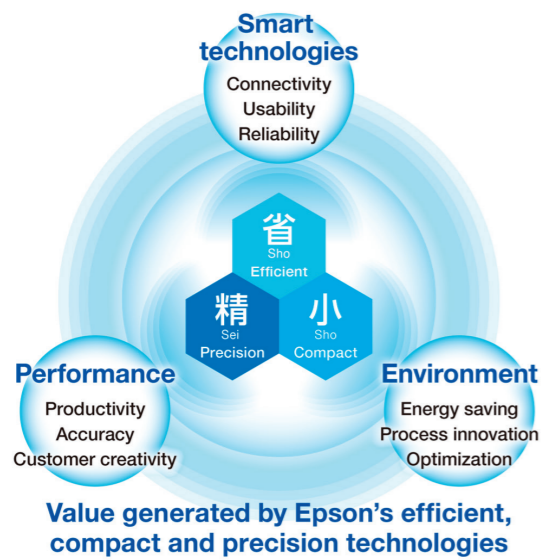

Smart technologies
Create convenient and easy-to-use products that can be used anytime and anywhere, and which help customers reduce waste, and save effort, time and money.

Environment
Leverage Epson products to reduce environmental impact by improving customers' work processes, and contribute to a sustainable society.

Performance
Use outstanding products to contribute to customers' performance through productivity, accuracy and creativity.

History of Epson Semiconductor's Technology

As the semiconductor division of "worldwide watch maker Seiko", semiconductor business has expanded into LCD Drivers, ASICs and MCUs from IC for Watches. These businesses are all based on Epson's energy-saving technology.

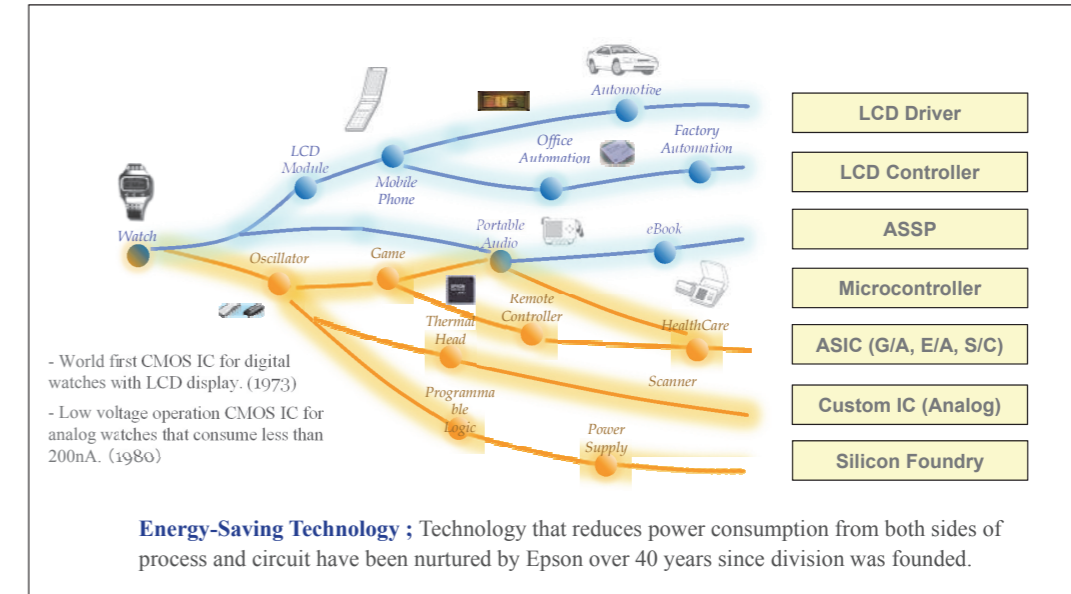

The role of Microdevices Div. and Semiconductor Business

Microdevices Vision and Strategy: Supporting the Four Innovations

Contribute to Epson's finished products and to the development of smart communications, power, transportation and manufacturing systems with advanced Epson quartz timing and sensing solutions and low-power semiconductor solutions.

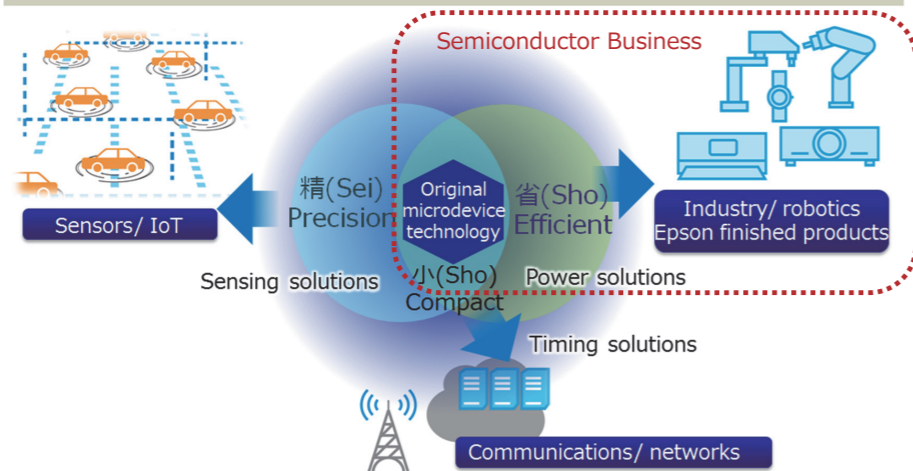

Semiconductor business contribute to the value creation of the Epson finished product, by advanced "Power Saving" solutions.

Epson Semiconductor's History



- 1969 Development of CMOS IC for watches started
- 1973 CMOS IC production started in Headquarter
- 1980 Fujimi plant (B-wing, 4 inch) operation started
- 1984 A-wing (5 inch) operation started
- 1985 D-wing (6 inch) operation started
- 1991 Sakata plant (S-wing, 6 inch) operation started
- 1993 ISO9000 series certified
- 1994 Singapore assembly plant (SEP) operation started
- 1997 T-wing (8 inch, Sakata) operation started
ISO14001 certified
- 2001 T-wing manufacturing line expanded
- 2006 ISO/TS16949 certified
- 2010 Microdevices Operations Division started
- 2017 IATF16949 certified

Low power microcontrollers

The technologies of low voltage operation and low power consumption acquired over the years through the development of 4-bit microcontrollers for watches and electronic shelf labels (ESL) are inherited by 16- and 32-bit microcontrollers today. The product lineup has been expanded, while achieving better throughputs. The display functions range from small-sized segment LDC drive to QVGA color display. A wide array of sensor interfaces recently attracting attention are also available. In addition to digital SIO such as SPI, UART, and I²C and the low power ADCs, the Epson original frequency conversion type ADC is capable of supporting measurements by resistance thermometer sensors and humidity sensors. A variety of these functions, low power technology and a highly efficient processor are all built into a single chip. With this one-chip solution, Epson continues to offer optimum products for small-sized battery-driven equipment, operation panel controllers, and sensor built-in healthcare products and housing equipment.

CPU Core Lineup

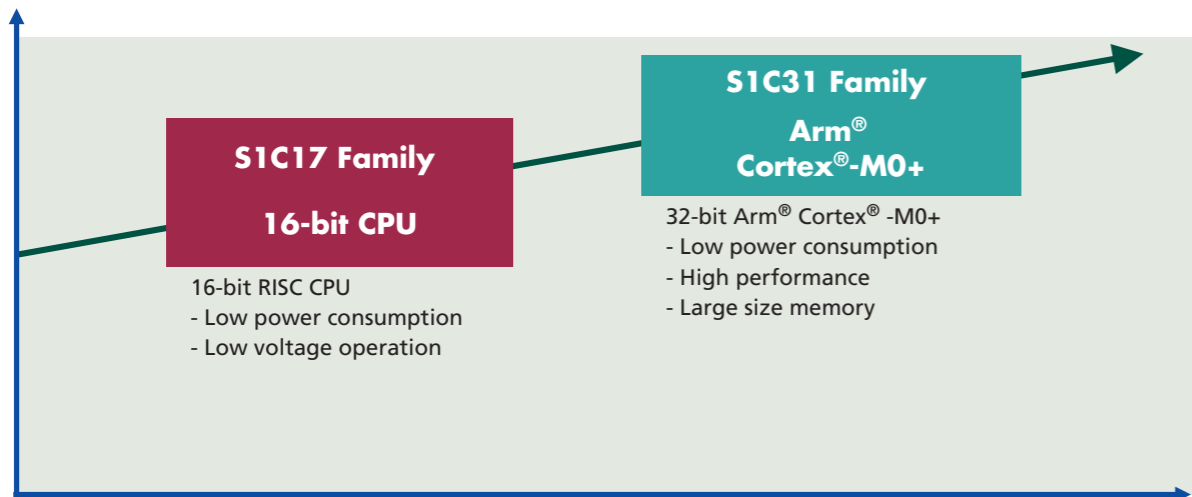

Application Example

Timepieces / Consumer

- Watch, Clock
- Sports watch
- Bike computer
- Remote controller
- White goods
- Label writer

FA, Household

- Time Switch
- Metering
- Thermostat
- Heat cost allocator
- Electronic shelf label
- Multi-meter

Healthcare / Medical

- Pedometer
- Activity monitor
- Insulin pen
- Blood pressure
- Body temp. measurement

Security products

- Smart card
- E-token
- Card reader
- Logistics tag

EPSON Low Power MCU

Lowest Current Consumption (16-bit microcontrollers)

In most cases, the S1C17 Family of products will allow customers currently using 8-bit microcontrollers to enjoy higher performance with the same power consumption. In addition, it will enable customers already using 16-bit/32-bit microcontrollers to benefit from longer battery life as a result of low operating voltage.

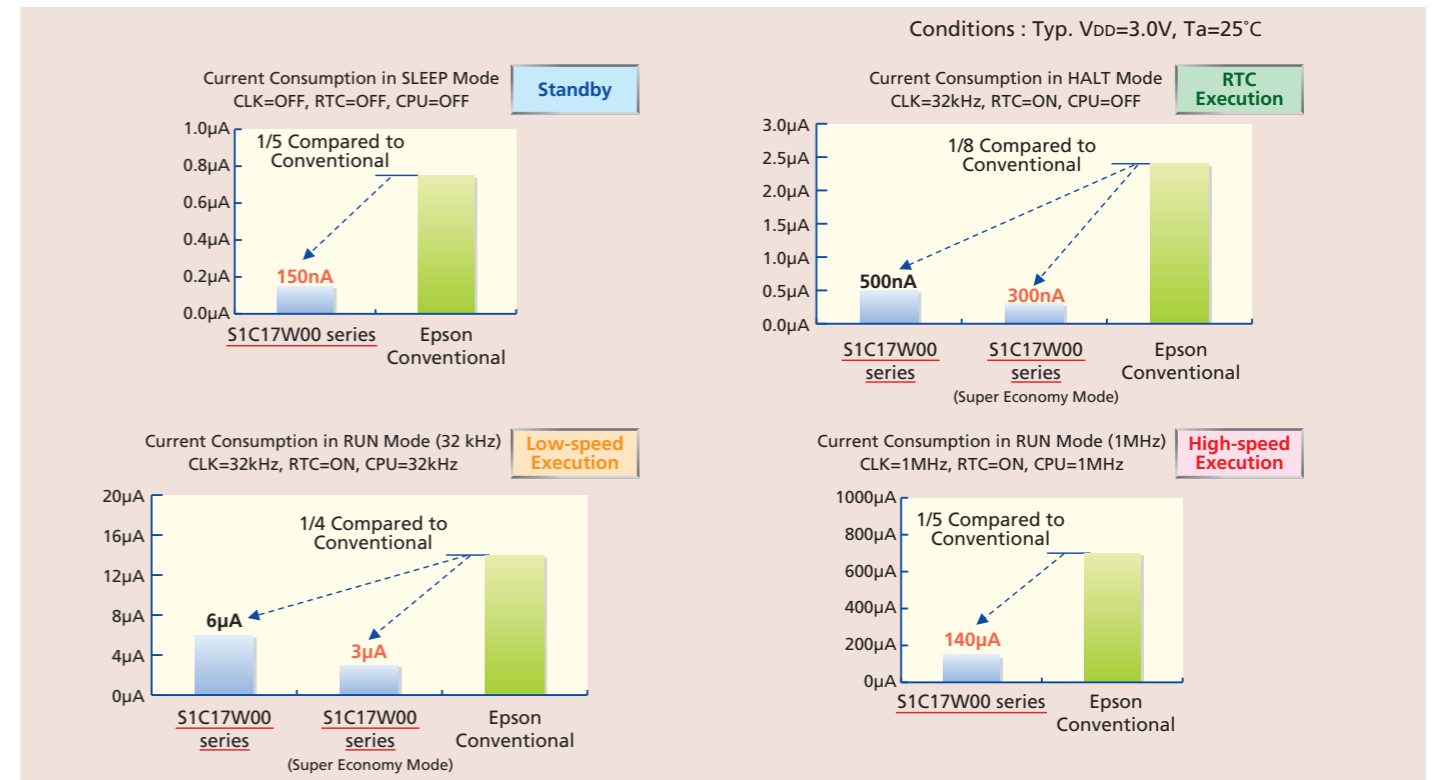

Four types of clock sources

Four types of characteristic clock sources can be freely selected for each circuit.

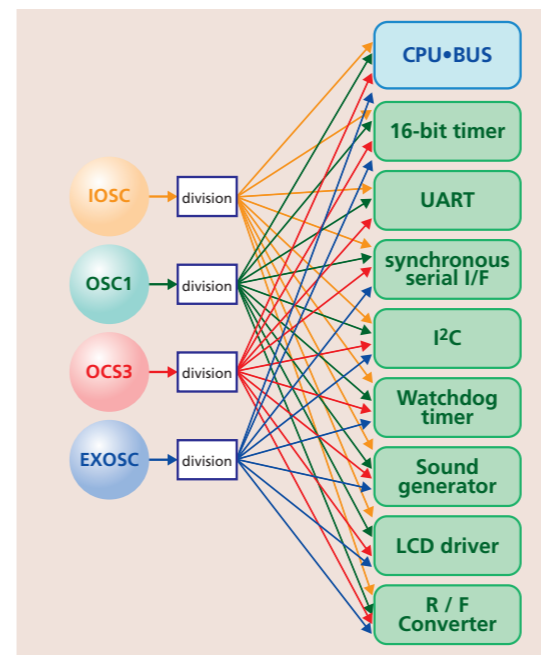

Terminals can be allocated freely (Universal Port Multiplexers)

SPI, I²C, UART, 16-bit PWM, and other terminals can be freely allocated as individual UPMUX terminals using software.

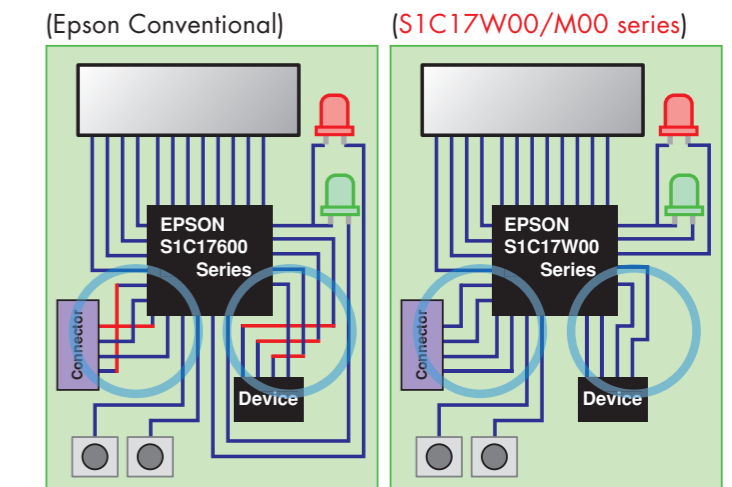

■ Supporting various types of LCD

• Black & White LCD driver

- Segment LCD driver
 - 12 to 88seg x 4/8com
 - 1/3 bias LCD voltage booster built-in
- Dot Matrix LCD driver
 - 56 to 128seg x 16/24/32/64com
 - 1/4,1/5 bias LCD voltage booster built-in

Models containing Black & White LCD driver :

- S1C17W10 group
- S1C17W20 group
- S1C17W30 group
- S1C17M30 group
- S1C17M40 group
- S1C31W00 series

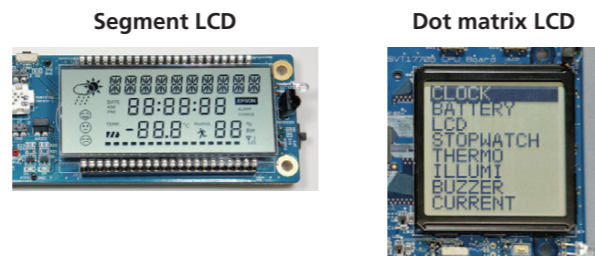
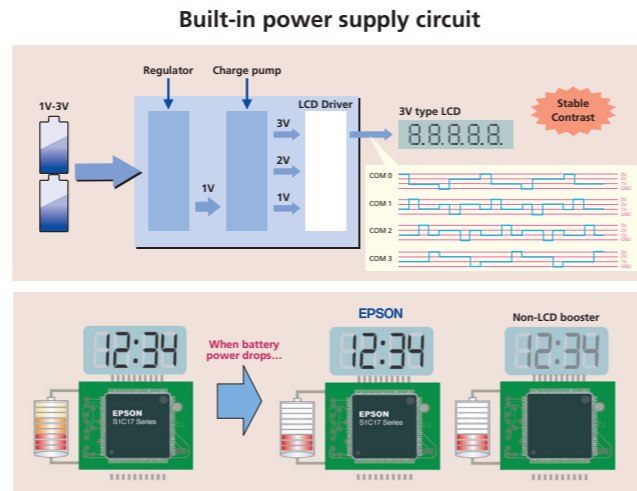

• LCD controller

- STN/TFT LCD controller
 - 320 x 240monochrome / 320 x 240 (QVGA)16gradations
- Memory display controller
 - 300 x 300 6-bit color / 640 x 640 Black & White
 - Supporting graphic engine function

Models containing LCD controller :

- S1C17800 series
- S1C31D00 series

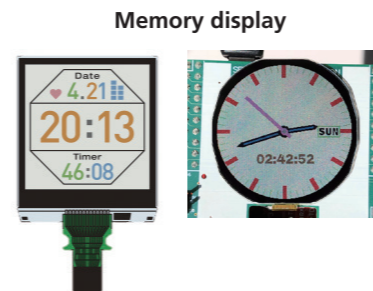

• Segment EPD driver

- 42 to 256seg + TP/BP
- Voltage booster built-in

Models containing EPD driver :

- S1C17F00 series



• Segment LED drive

- 8seg x 5com supporting 5V

Models containing LED driver :

- S1C17M12/M13



■ A large number of different types of interfaces are included

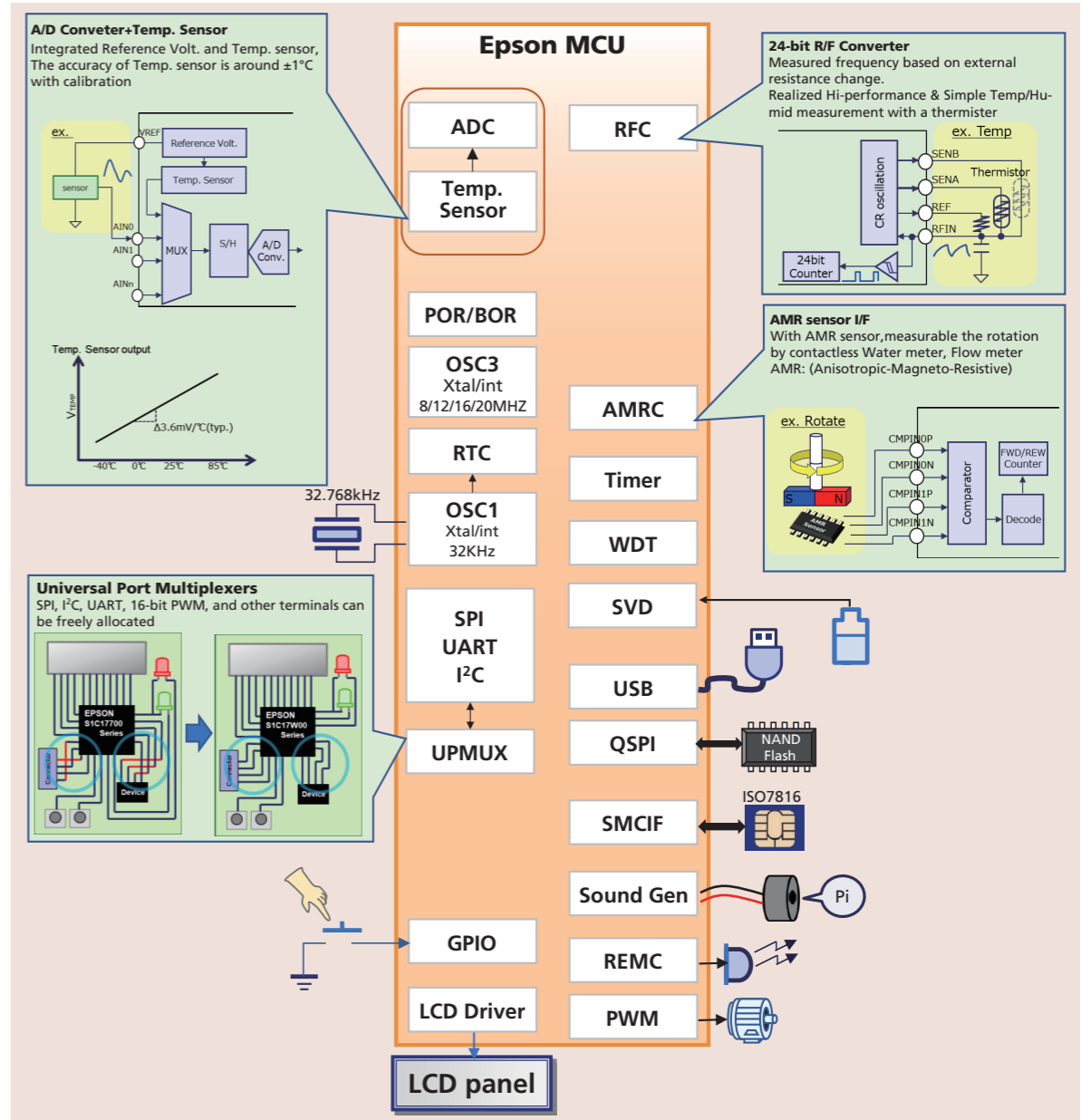

■ Product Dedicated Unique Peripherals

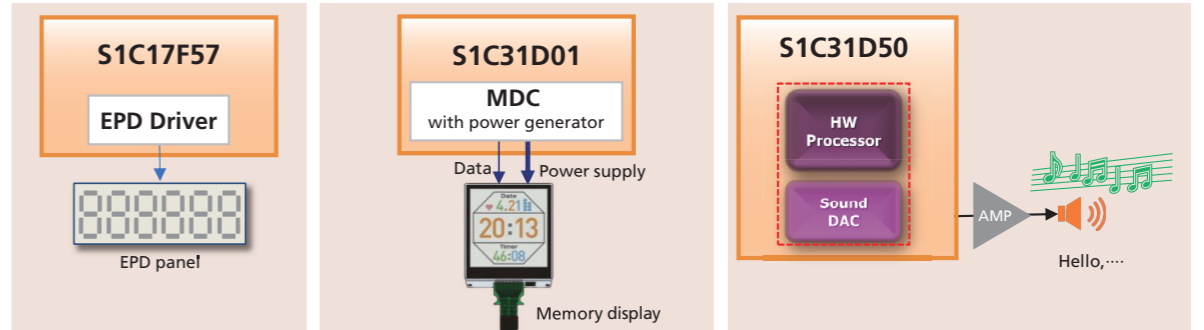

※: Peripheral circuits configured by products are different.

Suitable for wearable and industrial control devices Arm® microcontroller with LCD driver S1C31W00 Series

General

The S1C31W00 series is 32-bit MCU with an Arm® Cortex®-M0+ processor included that features low-power operation. It integrates LCD driver (max. 2,560-dot) and a lot of serial interface circuits.

Large capacity memory

Large capacity memory corresponding to market trend of multi functionality is integrated on a single chip. It is possible to store and operate user programs that size is increasing by complicated software design.

Built-in high resolution LCD driver

S1C31W series can drive dot-matrix or 7-segment LCD by built-in LCD driver. It equips internal constant voltage circuit that has been cultivated over the Epson traditional products, and can maintain display quality that is not affected by the remaining battery level. The contrast can be adjusted by software. It offers optimum and flexible design for user's product development.

Wide variety of interface

In addition to UART, SPI and I²C, it supports Quad-SPI (QSPI) which can communicate with external serial flash memory at high speed. An R/F converter for temperature and humidity measurement, USB FS 2.0 device controller, Universal port multiplexers that increase board layout design flexibility are also supported.

* It depends on the product which interface are supported.

Application example: Sport watch

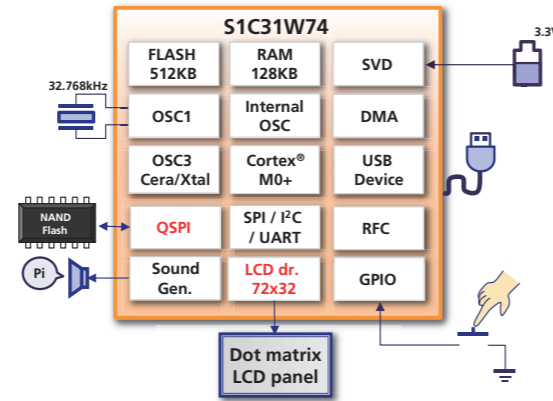

Application example: Industrial control device

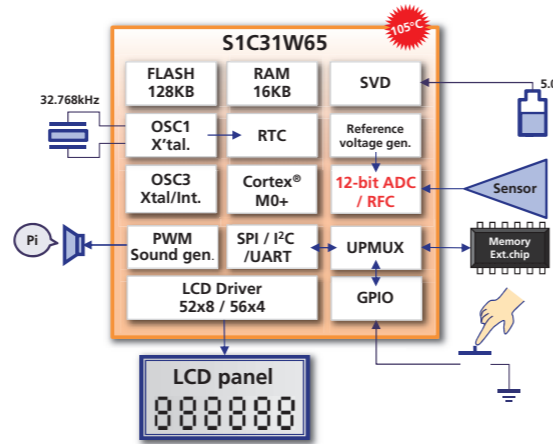

S1C31W00 Series Products overview

Products	Display Driver segxcom	Operation clock			Supply current				Power supply Supply voltage [V]	Memory			I/O port	Timer				SIO				Analog			Reset			Others		Form of delivery		
		High-speed [Hz] (Max.)	Low-speed [Hz] (Typ.)	Built-in oscillator [Hz] (Typ.)	Sleep [μA] (Typ.)	Halt [μA] (Typ.)	mode0 Operating [μA] (Typ.)	mode1 Operating [μA] (Typ.)		Flash ROM [Byte]	Display RAM [Byte]	RAM [Byte]		I/O port	16-bit timer	16-bit PWM timer	Watchdog timer	Real-time clock	UART	SPI	Quad SPI	I ² C	Remote controller transmission and reception	R/F converter (24-bit)	A/D converter (12-bit)	SVD	POR	BOR	Sound generator	USB	Special function	Package
S1C31W65	52 x 8 56 x 4	33M	32.768k	32k/1M/2M/ 8M/12M/16M/ 24M/32M	0.3	1.5	195	130	1.8 to 5.5	128K	112	16K	64	8	3 x 4	1	1	2	2	-	2	1	1	7	1	○	○	1	-	DMA	TQFP14-100	-
S1C31W73	96 x 16 88 x 24 80 x 32	33M	32.768k	32k/1M/2M/ 8M/12M/16M/ 24M/32M	0.7	2.0	214	150	1.8 to 5.5	384K	768	32K	73	8	2 x 4	1	1	2	2	1	2	1	1	7	1	○	○	1	1	DMA	QFP21-216	○
S1C31W74	88 x 16 80 x 24 72 x 32	21M	32.768k	1M/2M/8M/ 12M/16M/20M	0.4	1.7	250	150	1.8 to 3.6	512K	704	128K	71	4	2 x 2	1	1	2	1	2	1	1	-	2	○	○	1	1	-	-	VFBA8H-181	○

S1C31D00 Series Products overview

Products	Display controller	Operation clock			Supply current				Power supply Supply voltage [V]	Memory		I/O port	Timer				SIO				Analog			Reset			Others		Form of delivery		
		High-speed [Hz] (Max.)	Low-speed [Hz] (Typ.)	Built-in oscillator [Hz] (Typ.)	Sleep [μA] (Typ.)	Halt [μA] (Typ.)	mode0 Operating [μA] (Typ.)	mode1 Operating [μA] (Typ.)		Flash ROM [Byte]	RAM [Byte]		I/O port	16-bit timer	16-bit PWM timer	Watchdog timer	Real-time clock	UART	SPI	Quad SPI	I ² C	Remote controller transmission and reception	R/F converter (24-bit)	A/D converter (12-bit)	SVD	POR	BOR	Sound generator	USB	Special function	Package
S1C31D01	MDC	21M	32.768k	32k/1M/2M/ 8M/12M/16M/20M	0.46	1.7	250	155	1.8 to 5.5	256K	96K	57	8	2 x 6	1	1	3	2	1	2	1	-	7	1	○	○	1	1	DMA	WCSP96 TQFP14-80 VFBA5H-81	○
S1C31D50 / 51	-	16M	32.768k	32k/4M/8M/16M	0.46	1.8	250	155	1.8 to 5.5	192K	8K	39 55 71 91	8	2 x 4	1	1	3	3	1	3	1	1	5 7 8 8	1	○	○	-	-	DMA Sound HW	TQFP12-48 QFP13-64 TQFP14-80 QFP15-100	-
S1C31D41	-	16M	32.768k	32k/4M/8M/16M	TBD	TBD	TBD	TBD	1.8 to 5.5	96K	8K	25 39 55	8	2 x 4	1	1	3	3	1	3	1	1	6 7 8	1	○	○	-	-	DMA Sound HW	TQFP12-32 TQFP12-48 TQFP13-64	-

Suitable for battery-driven wearable products Arm® microcontroller with a memory display controller "S1C31D01"

General

The S1C31D01 is a 32-bit MCU with an Arm® Cortex®-M0+ processor included that features low-power operation. It integrates a lot of serial interface circuit, a memory display controller, and a voltage booster.

Memory Display Controller (MDC)

MDC supports several panel interfaces for each memory display. It includes graphics hardware acceleration functions such as rotation of frame buffer image to panel, Image/bitmap copy with scaling/rotation/horizontal and vertical shearing/alpha-blending*, Line/Rectangle/Ellipse/Arc drawing with filled and unfilled.

It can contribute to reduce software load by dedicated hardware.

Power booster circuit

The S1C31D01 generates supply voltages for memory display (VMDH/VMDL) with programmable power booster circuit. It is possible to reduce external components.

Small size package

Wafer level Chip Size Package (WCSP) is supported as same size with chip. It is suitable for various applications which have limited mounting area on the print circuit board.

Lineup

Epson prepares CPU-less dedicated memory display controller "S1D13C00" for the customers who already have Host CPU. It supports same features with S1C31D01 about graphic acceleration function and power booster circuit. There is a variety of products that can be selected according to your system.

Examples of Graphic Acceleration

Drawing Engine



Image / Bitmap copy

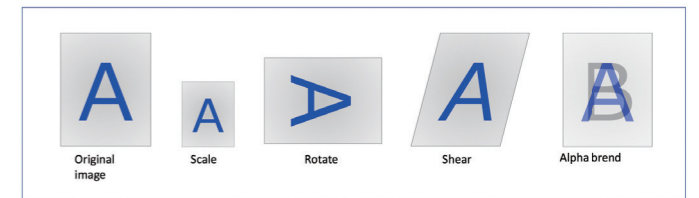

Application Example: Sport watch

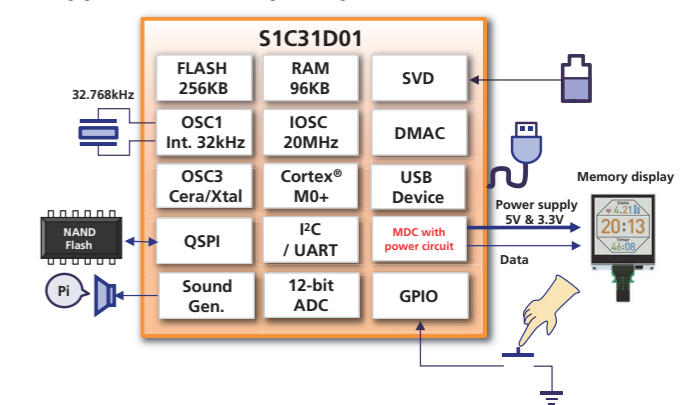

* Alpha-blending: supported at 6-bit color only.

ideal sound solution for home appliances and electronics Arm® microcontroller with Dedicated Sound Hardware "S1C31D50/51/41"

General

The S1C31D50/51/41 is a 32-bit Arm® Cortex®-M0+ MCU which integrates a specific hardware block called the HW Processor.

HW Processor

The HW Processor can perform 2ch Voice/Audio Play, Voice Speed Conversion, and Self Memory Check without using any CPU resources.

2ch mixing play

A dedicated HW Processor provides 2-channel sound on a single MCU chip. The use of two channels enables music and voice to be played simultaneously. The audio guidance becomes more elegant and warmer.

Voice Speed Conversion

The speed of the easy-to-hear voice depends on the end user. This function enable to adjust the speed by the end user.

Buzzer Voice play(D51/D41)

By making it possible to output voice guidance sound like error and

warning messages on a buzzer instead of a speaker, the usability of the MCU is increased. Common buzzer sound output performance is often very poor because of low volume and limited bandwidth. Epson improved buzzer performance by using new development algorithm.

Pitch conversion(D41)

The pitch of the comfortable-to-hear voice depends on the end user. This function enable to adjust the speed by the end user.

High-compression Sound Algorithm

Epson high-compression algorithm(EOV) cultivated in Epson LSI business is inherited. For example, the data size of 1min voice at 15.625kHz sampling frequency is about 120KB. It is 1/4 size of the data created by ADPCM.

Self-Memory Check

HW processor can detect failures in built-in RAM, built-in Flash, and external SPI-Flash memories without using CPU resources.



Block Diagram

	S1C31D50	S1C31D51	S1C31D41
Flash	192KB(For Program and Sound)		96KB(For Program and Sound)
RAM	8KB +14KB HW Processor not active	10KB +12KB HW Processor not active	8KB +18KB HW Processor not active
HW Processor	2ch mixing play(ch0 and ch1) Voice Speed Conversion(only ch0) Voice Pitch Conversion(D41) Self Memory Check(On Chip RAM, On Chip Flash, External SPI-Flash)		
Sound DAC	Sampling Frequency: 15.625kHz		
Serial Interface	SPI(3ch), UART(3ch), I ² C(3ch), QSPI(1ch)		
Sound Play Method	AMP + Speaker	AMP + Speaker Simple circuit + Speaker Simple circuit + Buzzer	
ADC	12-bit (Max. 8-port)		12-bit (Max. 8-port, 1-port for temperature sensor)
SVD	V _{DD} : 28 levels (1.8V to 5.0V)/External voltage: 32 levels (1.2V to 5.0V)		
DMA	4ch (Memory ⇄ Memory, Memory ⇄ Peripheral)		
RFC	CR oscillation type 24-bit counters		
Timers	16-bit Timer (8ch), 16-bit PWM (2ch), WDT, RTC		
Power Supply	1.8V to 5.5V V _{DD} 3.3V SPI-Flash Interface Power Supply		
Flash Programming	2.7V to 5.5V		2.2V to 5.5V
Clock Frequency	Max. 16MHz (internal power: 1.8V) Max. 1.8MHz (internal power: 1.2V)		TBD
Power Consumption	Standard Mode RUN: 250μA/MHz (internal: 1.8V) Low Power Mode RUN: 150μA/MHz (internal: 1.2V) Max. 1.8MHz SLEEP: 0.4μA, RTC mode: 0.9μA		TBD
Package	P-TQFP048-0707-0.50 P-LQFP064-1010-0.50 P-TQFP080-1212-0.50 P-LQFP100-1414-0.50		P-TQFP032-0707-0.80 P-TQFP048-0707-0.50 P-LQFP064-1010-0.50
IEC-60730	supported by Sample SW		

Block Diagram

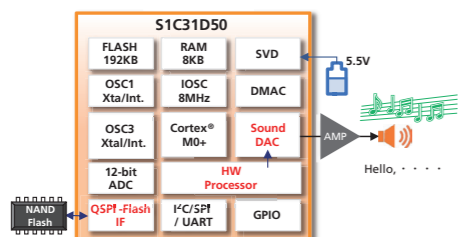

Applications

Boiler Remote Controller
Fire/Smoke Alarm

User-Friendly Substantial Development Environment Voice Creation PC Tool, Simple sound play interface, easy sound data update in market

S1C31D50/51/41 Development Environment provides User-Friendly Substantial Development, this makes it easy to create natural voice data and play the sound.

Epson Voice Creation PC Tool

Using Epson Voice Creation PC Tool, natural voice data can be created by just PC, so no need to struggle studio recording, announce arrangement and additional cost. Typically only text input to the tool is enough to create the voice data. The tool also supports phrase combination, pronunciation adjust and importing existing WAV file a customer already has.

[Supported Languages]

Asia : Japanese, Chinese (Mandarin), Korean
America : American English, American Spanish, Canadian French
Europe : British English, German, French, Spanish, Italian, Russian

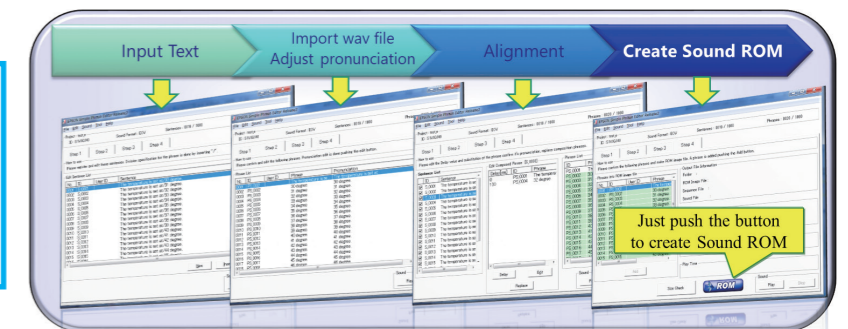

Link between Voice creation Tool and IC

Epson Voice Creation PC tool also makes it easy to develop firmware. A firmware engineer does not need to care phrase combination and delay among phrases etc, because all information is included in Sound ROM and Hardware Processor. By just setting the Sentence Number on the tool to IC register, the sound can be played.

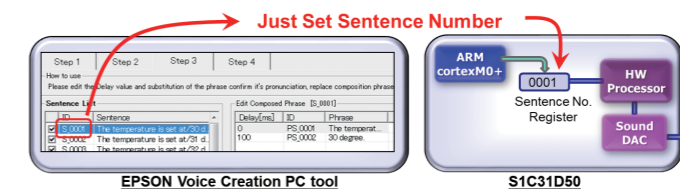

Easy to add, management of the languages

By Multiple SoundROM capability, it's easy to add/modify on the market, management of the languages.

By having same meaning sentence on each language, the sequence can be shared.

It's just set start address and the size to switch SoundROM.

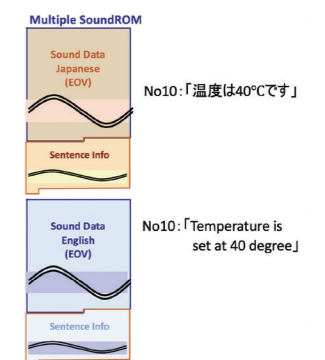

Evaluation Board

4 languages sound demo with melody is preset. Pushing the button on the evaluation board, 2ch mixing sound can be played.

Also customers can write new sound ROM Data from PC to this board and play own sound easily.

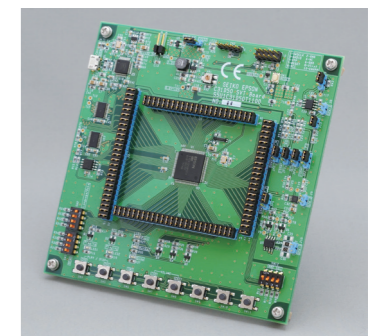

World realized by low power consumption of the S1C17W00 Series

Case of Digital Watch

Conditions: Continuous LCD watch display using LR44 battery (1.5 V)

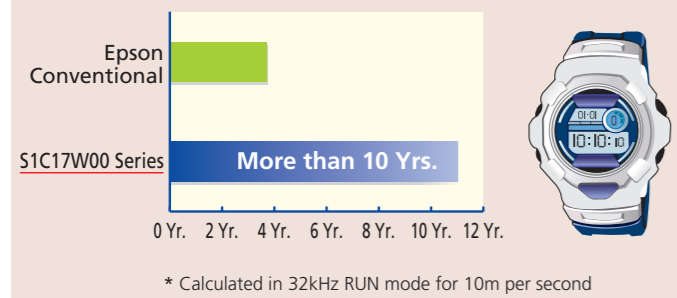

Case of Pedometer

Conditions: LCD display and acceleration sensing for several hours per day using the CR2032 battery (3V)

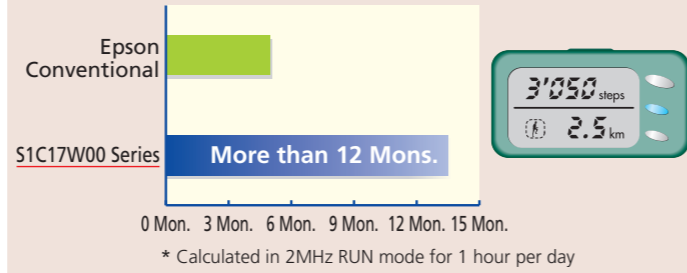

S1C17W00 Series Products overview

Products	Display	Operation clock			Supply current				Power supply	Memory		I/O port	Timer				SIO				Analog				Others		Form of delivery		
		LCD Driver segxcom	High-speed [Hz] (Max.)	Low-speed [Hz] (Typ.)	Built-in oscillator [Hz] (Typ.)	Sleep [μA] (Typ.)	Halt [μA] (Typ.)	32kHz Operating [μA] (Typ.)		1MHz Operating [μA] (Typ.)	Flash ROM [Byte]		RAM [Byte]	I/O port	16-bit timer	16-bit PWM timer	Watchdog timer	Real-time clock	UART	SPI	QSPI	I ² C	Remote controller transmission and reception	R/F converter (24-bit)	A/D converter (12-bit)	SVD *4	Sound generator	Multiple r/Divider	Special function
S1C17W00 series W00 group		[Ultra Low Power] This is an ultra-low power consumption 16-bit MCU compatible to low voltage operations from 1.2V, even with built-in flash memory. This product is equipped with a built-in RTC, stopwatch, high-performance PWM, external bus I/F and improved analog functions, combined with the powerful processing capacity of the 16-bit CPU, suitable for battery driven applications.											The embedded highly efficient DC-DC converter generates an internal constant voltage, to drive an IC with a low power consumption operation beyond 4-bit MCUs.																
S1C17W03	-	4.2M	32.768k	250k/384k/500k/700k/1M/2M/4M	0.15	0.3	4	250	1.2 to 3.6	16K ⁺³	2K	35/24	4	2 x 2	1	1	2	2	-	1	1	2 ⁺⁵ 1	6 5	1	1	1	-	TQFP12-48	○
S1C17W04	-	4.2M	32.768k	250k/384k/500k/700k/1M/2M/4M	0.15	0.3	4	250	1.2 to 3.6	32K ⁺³	2K	35/24	4	2 x 2	1	1	2	2	-	1	1	2 ⁺⁵ 1	6 5	1	1	1	-	TQFP12-48	○
S1C17W00 series W10/W20/W30 group		[Ultra Low Power] This is an ultra-low power consumption 16-bit MCU compatible to low voltage operations from 1.2V, even with built-in flash memory. LCD driver, high-performance PWM and improved analog functions, combined with the powerful processing capacity of the 16-bit CPU, suitable for battery driven applications.											The embedded highly efficient DC-DC converter generates an internal constant voltage, to drive an IC with a low power consumption operation beyond 4-bit MCUs. This product is equipped with a built-in RTC, driven applications that require a LCD and clock function.																
S1C17W12	26 x 4 18 x 4	4.2M	32.768k	32k/250k/384k/500k/700k/1M/2M/4M	0.15	0.3 1.5	2 5	140	1.2 to 3.6	48K ⁺³	2K	32/26	3	2 x 2	1	1	2	1	-	1	1	2 ⁺⁵ -	-	1	1	1	LED pin x 2	-	○
S1C17W13	26 x 4 18 x 4 20 x 4	4.2M	32.768k	32k/250k/384k/500k/700k/1M/2M/4M	0.15	0.3	2 4	140	1.2 to 3.6	48K ⁺³	2K	32/26	3	2 x 2	1	1	2	1	-	1	1	2 ⁺⁵ -	-	1	1	1	LED pin x 2	○	
S1C17W14	54 x 4 50 x 8	4.2M	32.768k	250k/384k/500k/700k/1M/2M/4M	0.15	0.3	3	200	1.2 to 3.6	48K ⁺³	4K	33	3	2 x 2	1	1	2	2	-	1	1	1	-	1	1	1	-	QFP15-100	○
S1C17W15	34 x 4 30 x 8 32 x 4 28 x 8 24 x 4 20 x 8	4.2M	32.768k	500k/700k/1M/2M/4M	0.15	0.3 0.5	4 8	250	1.2 to 3.6	64K ⁺³	4K	36/33/28	3	2 x 2	1	1	2	1	-	1	-	4 ⁺⁵ -	-	1	1	1	-	QFP15-100	○
S1C17W16	60 x 4 56 x 8	4.2M	32.768k	250k/384k/500k/700k/1M/2M/4M	0.15	0.3	3	200	1.2 to 3.6	64K ⁺³	8K	40	5	2 x 2	1	1	2	3	-	1	1	2 ⁺⁵ -	4	1	1	1	-	TQFP15-128	○
S1C17W18	48 x 4 44 x 8 32 x 4 28 x 8 24 x 4 20 x 8	4.2M	32.768k	250k/384k/500k/700k/1M/2M/4M	0.15	0.3 0.5	2 4	140	1.2 to 3.6	128K ⁽⁺³⁾	8K	68/59/49	4	3 x 2	1	1	2	2	-	1	1	2 ⁺⁵ -	7	1	1	1	Temperature sensor	TQFP15-128	○
S1C17W22	72 x 4/8 64 x 16 56 x 24	4.2M	32.768k	500k/700k/1M/2M/4M	0.15	0.3	4	250	1.2 to 3.6	64K ⁺³	4K	42	2	2 x 2	1	1	1	1	-	1	1	2 ⁺⁵ -	-	1	1	1	-	TQFP15-128	○
S1C17W23	72 x 4/8 64 x 16 56 x 24	4.2M	32.768k	500k/700k/1M/2M/4M	0.15	0.3	4	250	1.2 to 3.6	96K ⁺³	8K	42	4	3 x 2	1	1	2	2	-	1	1	2 ⁺⁵ -	6	1	1	1	-	TQFP15-128	○
S1C17W34	80 x 16 64 x 32	4.2M	32.768k	250k/384k/500k/700k/1M/2M/4M	0.15	0.4	3	150	1.2 to 3.6	128K ⁽⁺³⁾	12K	53	4	3 x 2	1	3	2	2	-	1	1	2 ⁺⁵ -	7	1	1	1	Temperature sensor	QFP21-176	○
S1C17W35	80 x 16 64 x 32	4.2M	32.768k	250k/384k/500k/700k/1M/2M/4M	0.15	0.4	3	150	1.2 to 3.6	256K ⁽⁺³⁾	12K	53	4	3 x 2	1	3	2	2	-	1	1	2 ⁺⁵ -	7	1	1	1	Temperature sensor	QFP21-176	○
S1C17W36	80 x 16 64 x 32	4.2M	32.768k	250k/384k/500k/700k/1M/2M/4M	0.15	0.4	3	150	1.2 to 3.6	384K ⁽⁺³⁾	16K	53	4	3 x 2	1	3	2	2	-	1	1	2 ⁺⁵ -	7	1	1	1	Temperature sensor	QFP21-176	○

*1: During erasing / programming in flash memory (V_{DD}): 1.8V to 3.6V

*2: During operations LCD (V_{DD}): 2.5V to 3.6V

*3: During erasing / programming voltage in flash memory (V_{PP}): The external applying of 7.5V / 7.5V (Typ.) is needed. (*3) can be rewritten even with internal power supply.

*4: SVD is an abbreviation for Supply Voltage Detector.

*5: Independent operation for each channel.

S1C17W00 Series Application examples

Example of an application using the S1C17W13: Remote controller

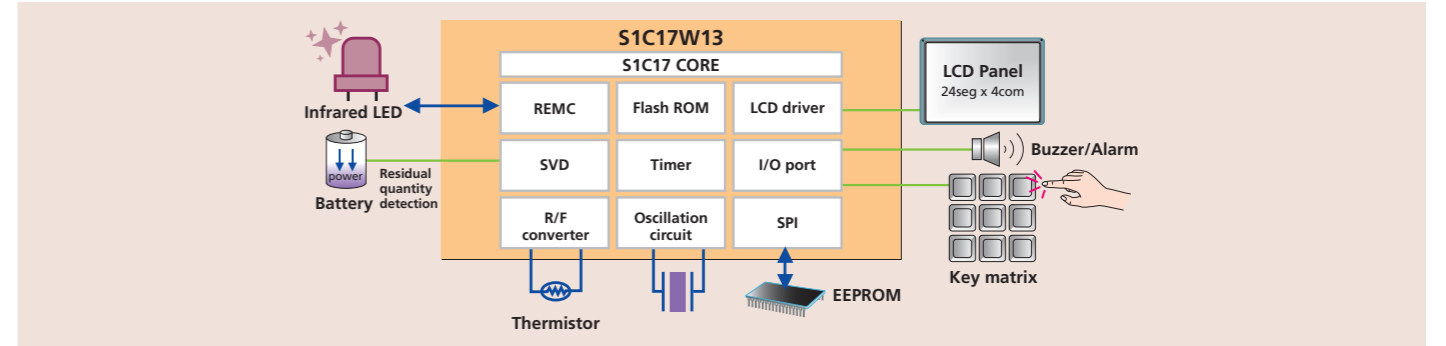

■ S1C17M00 Series Application examples

Example of an application using the S1C17M40: FA/Industrial control device

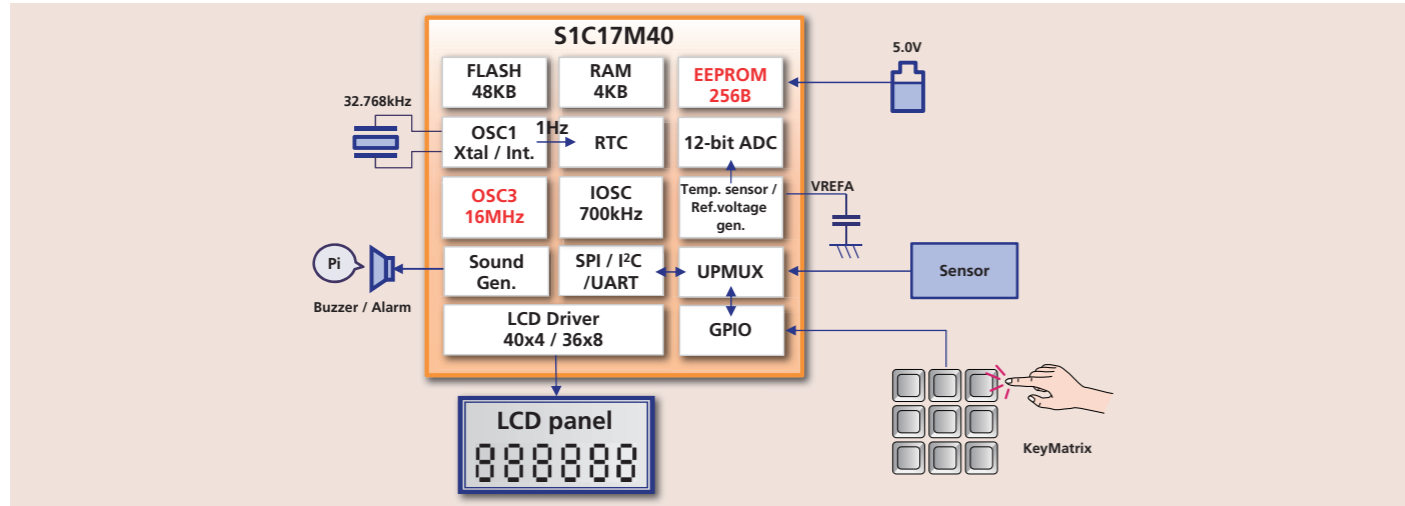

■ S1C17M00 Series Products overview

Products	Display		Operation clock			Supply current				Power supply	Memory			I/O port	Timer				SIO				Analog			Reset		Others			Form of delivery		
	LCD Driver segxcom	Display controller	High-speed [Hz] (Max.)	Low-speed [Hz] (Typ.)	Built-in oscillator [Hz] (Typ.)	Sleep [μA] (Typ.)	Halt [μA] (Typ.)	32kHz Operating [μA] (Typ.)	1MHz Operating [μA] (Typ.)	Supply voltage [V]	Flash ROM [Byte]	EEPROM [Byte]	RAM [Byte]		16-bit timer	16-bit PWM timer	Watchdog timer	Real-time clock	UART	SPI	Quad SPI	I ² C	Remote controller transmission and reception	R/F converter (24-bit)	A/D converter (12-bit)	SVD ^{*4}	POR	BOR	Sound generator	Multiple r/Divider	Special function	Package	Chip
S1C17M00 series																																	
It is an application specialized series. It is a 16-bit MCU with Flash memory compatible with high processing while achieving low power consumption, supporting power supply voltages from 1.8 V to 5.5 V.																																	
S1C17M01	32 x 4 28 x 8	-	16.3M	32.768k	7.37M	0.35	0.8	12.5	210	1.8 to 5.5 ^{*7}	32K ^{*3}	-	4K	19	5	-	1	1	1	2	-	1	-	1	-	-	-	-	-	AMRC	TQFP13-64	○	
S1C17M10	88 x 8 80 x 16	-	16M	32.768k	32k/ 4M/8M/ 12M/16M	0.16	0.6	4	145	1.8 to 5.5 ^{*2}	64K ^{(*)3}	-	4K	33	5	1 x 2	1	1	1	-	1	-	-	1	○	-	-	1	SMCIF	TQFP15-128	○		
S1C17M12	-	LED controller 8x5	16.8M	-	4M/8M/ 12M/16M	0.35	40	-	150	1.8 to 5.5 ^{*2}	16K ^{*3}	-	2K	39	4	1 x 2	1	-	1	2	-	1	-	-	1	○	○	-	1	High current port x 5	TQFP12-48	○	
S1C17M13	-	LED controller 8x5	16.8M	-	4M/8M/ 12M/16M	0.35	40	-	150	1.8 to 5.5 ^{*2}	16K ^{*3}	-	2K	39	4	1 x 2	1	-	1	2	-	1	-	8	1	○	○	-	1	High current port x 5	TQFP12-48	○	
S1C17M20	-	-	21M	-	32k/700k/ 12M/16M/20M	0.36	1.5 0.7	5.5 5	160	1.8 to 5.5 ^{*2}	16K ^{(*)3}	-	2K	18 24	4	2 x 2	1	1	2	2	-	1	1	-	4 6	1	○	○	1	1	-	SQFN4-24 SQFN5-32	-
S1C17M21	-	-	21M	32.768k	32k/700k/ 12M/16M/20M	0.36	0.7	5	160	1.8 to 5.5 ^{*2}	16K ^{(*)3}	-	2K	24	4	2 x 2	1	1	2	2	-	1	1	-	6	1	○	○	1	1	-	TQFP12-32	-
S1C17M22	-	-	21M	32.768k	32k/700k/ 12M/16M/20M	0.36	0.7	5	160	1.8 to 5.5 ^{*2}	16K ^{(*)3}	-	2K	40	4	2 x 2	1	1	2	2	-	1	1	2	8	1	○	○	1	1	-	TQFP12-48	-
S1C17M23	-	-	21M	-	32k/700k/ 12M/16M/20M	0.36	1.5 0.7	5.5 5	160	1.8 to 5.5 ^{*2}	32K ^{(*)3}	-	2K	18 24	4	2 x 2	1	1	2	2	-	1	1	-	4 6	1	○	○	1	1	-	SQFN4-24 SQFN5-32	-
S1C17M24	-	-	21M	32.768k	32k/700k/ 12M/16M/20M	0.36	0.7	5	160	1.8 to 5.5 ^{*2}	32K ^{(*)3}	-	2K	24	4	2 x 2	1	1	2	2	-	1	1	-	6	1	○	○	1	1	-	TQFP12-32	-
S1C17M25	-	-	21M	32.768k	32k/700k/ 12M/16M/20M	0.36	0.7	5	160	1.8 to 5.5 ^{*2}	32K ^{(*)3}	-	2K	40	4	2 x 2	1	1	2	2	-	1	1	2	8	1	○	○	1	1	-	TQFP12-48	-
S1C17M30	26 x 4 22 x 8 ^{*6}	-	16.8M	32.768k	32k/700k/ 12M/16M	0.2	0.7	5	160	1.8 to 5.5 ^{*2}	48K ^{(*)3}	256 ^{*8}	4K	38	4	3 x 2	1	1	2	2	-	1	1	2	2	1	○	○	1	1	-	TQFP12-48	-
S1C17M31	26 x 4 22 x 8	-	16.8M	-	32k/700k/ 12M/16M	0.2	1.4	5.5	160	1.8 to 5.5 ^{*2}	48K ^{(*)3}	256 ^{*8}	4K	38	4	3 x 2	1	1	2	2	-	1	1	2	2	1	○	○	1	1	-	TQFP12-48	-
S1C17M32	42 x 4 38 x 8 ^{*6}	-	16.8M	32.768k	32k/700k/ 12M/16M	0.2	0.7	5	160	1.8 to 5.5 ^{*2}	64K ^{(*)3}	256 ^{*8}	4K	54	4	3 x 2	1	1	2	2	-	1	1	2	2	1	○	○	1	1	-	TQFP13-64	-
S1C17M33	50 x 4 46 x 8	-	16.8M	32.768k	32k/700k/ 12M/16M	0.2	0.7	5	160	1.8 to 5.5 ^{*2}	96K ^{(*)3}	32 to 512 ^{*8}	4K	66	4	3 x 2	1	1	2	2	-	1	1	2	5	1	○	○	1	1	-	TQFP14-80	○
S1C17M34	37 x 4 33 x 8	-	16.8M	32.768k	32k/700k/ 12M/16M	0.2	0.7	5	160	1.8 to 5.5 ^{*2}	64K ^{(*)3}	256 ^{*8}	4K	52	4	3 x 2	1	1	2	2	-	1	1	2	5	1	○	○	1	1	-	TQFP13-64	-
S1C17M40	40 x 4 36 x 8	-	16.8M	32.768k	32k/700k/ 16M	0.25	0.7	5	-	1.8 to 5.5 ^{*1}	48K	256	2K	55	4	3 x 2	1	1	3	2	-	1	1	-	4	1	○	○	1	1	-	QFP13-64	-
	28 x 4 24 x 8	-	16.8M	-	32k/700k/ 16M	0.25	1.4	5.5	-	1.8 to 5.5 ^{*1}	48K	256	2K	41	4	3 x 2	1	1	3	2	-	1	1	-	3	1	○	○	1	1	-	TQFP12-48	-

*1: During erasing / programming in flash memory / EEPROM programming (V_{DD}): V_{PP}=2.2V to 5.5V
*2: During erasing / programming in flash memory (V_{DD}): 2.7V to 5.5V, 2.4V to 5.5V during the external applying V_{PP}=7.5V / 7.5V (Typ.)

■ S1C17M00 Series Function introduction

Example of 7 seg LED lighting up using the S1C17M12/M13

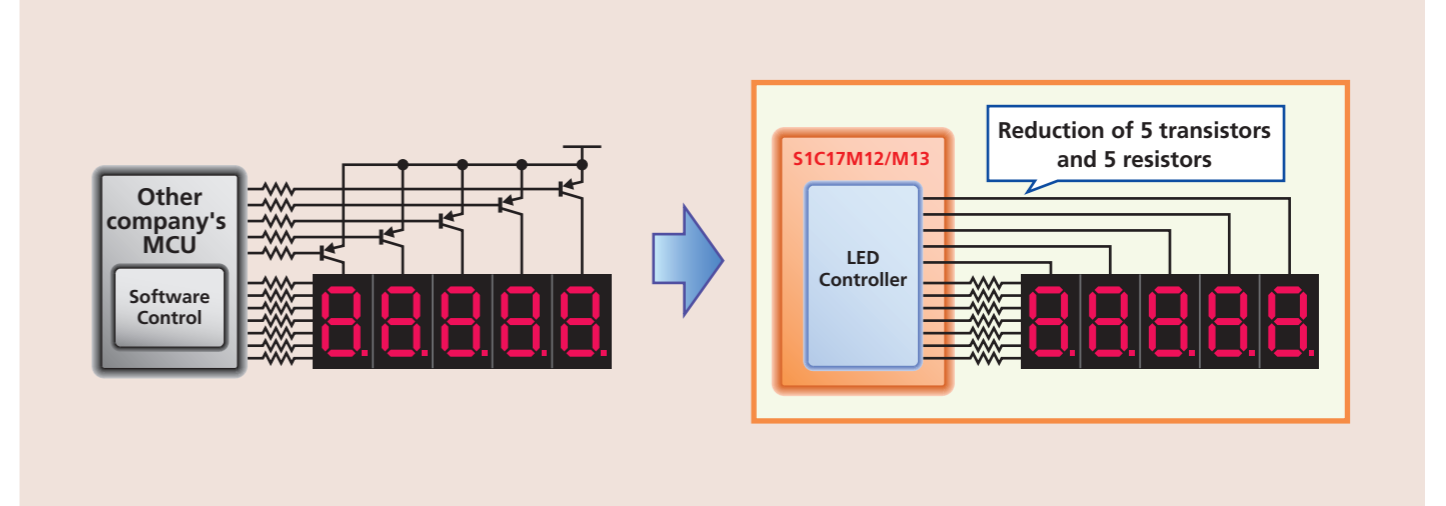

*4: SVD is an abbreviation for Supply Voltage Detector.
*5: Output dedicated port 1 included.
*6: External voltage application mode only, to 5.5V

*7: (MR sensor controller) Operation (V_{DD}): 2.0V to 5.5V
*8: AMRC Flash area is used.
*9: During erasing / programming in flash memory (V_{DD}): 2.4V to 5.5V

■ S1C17 Long-running Series

Products	Display	Operation clock			Supply current				Power supply	Memory			I/O							SIO					Analog			Others			Form of delivery			
	LCD Driver segxcom	High-speed [Hz] (Max.)	Low-speed [Hz] (Typ.)	Built-in oscillator [Hz] (Typ.)	Sleep [μA] (Typ.)	Halt [μA] (Typ.)	32kHz Operating [μA] (Typ.)	1MHz Operating [μA] (Typ.)	Supply voltage [V]	Flash ROM [Byte]	Mask ROM [Byte]	RAM [Byte]	I/O port	8-bit timer	16-bit timer	16-bit PWM timer	Stopwatch	Watchdog timer	Clock	Real-time clock	UART	SPI	I ² C master	I ² C slave	Remote controller transmission and reception	RF converter (24-bit)	A/D converter (10-bit)	SVD*5	Sound generator	Multiplier/Divider	Special function	Package	Chip	
S1C17100/600 series	[Low Power] This is a 16-bit MCU with improved processing capacity and development environment, while maintaining low power consumption equivalent to This product is equipped with a built-in segment LCD driver, power circuit, clock function and various I/F, suitable for watches, clocks, remote controllers and												Epson's 4/8-bit MCUs. healthcare devices.																					
S1C17153	32 x 4	–	32.768k	500k/1M/2M	0.13	0.42	4	160	2.0 to 3.6	–	16K	2K	12	1	–	1	–	1	1	1	1	–	–	–	–	–	1	1	1	–	–	–	–	
S1C17121	40 x 4 36 x 8	4.2M	32.768k	2.7M	0.15	0.9	7	250	1.8 to 3.6	–	32K	2K	36	3	3	1	1	1	–	2	1	1	1	1	2	8	1	–	1	–	–	TQFP14-100	○	
S1C17651	20 x 4	4.2M	32.768k	32k/500k/1M/2M	0.09	0.42	10	350	2.0 to 3.6	16K _{*3}	–	2K	12	1	–	1	–	1	1	1	1	–	–	–	–	–	1	1	1	–	–	–	TQFP13-64	○
S1C17653	32 x 4	4.2M	32.768k	32k/500k/1M/2M	0.09	0.42	10	350	2.0 to 3.6	16K _{*3}	–	2K	12	1	–	1	–	1	1	1	1	–	–	–	–	–	1	1	1	–	–	–	TQFP14-80	○, *7
S1C17656	32 x 4	–	32.768k	500k/1M/2M/4M	0.13	0.5	7.3	280	1.8 to 3.6	24K _{*4}	–	2K	20	1	–	1	–	1	1	1	1	–	–	–	1	–	1	1	1	–	–	–	TQFP14-80	○
S1C17611	12 x 4 8 x 8	8.2M	32.768k	2.7M	0.6	2.0	12	400	1.8 to 3.6 _{*1}	32K _{*6}	–	2K	19	2	3	2	1	1	1	–	1	1	1	–	1	4	1	–	1	–	–	QFP12-48	○	
S1C17601	20 x 4 16 x 8	8.2M	32.768k	2.7M	0.6	2.0	12	340	1.8 to 3.6 _{*1}	32K _{*6}	–	2K	24	2	3	2	1	1	1	–	1	1	1	–	1	4	1	–	1	–	–	TQFP13-64	○	
S1C17621	40 x 4 36 x 8	8.2M	32.768k	2.7M	0.75	2.5	15	410	1.8 to 3.6 _{*1}	32K _{*6}	–	2K	36	3	3	1	1	1	1	–	2	1	1	1	2	8	1	–	1	–	–	TQFP14-100	○	
S1C17602	40 x 4 36 x 8	8.2M	32.768k	2.7M	0.75	2.5	15	410	1.8 to 3.6 _{*1}	64K _{*6}	–	4K	36	3	3	1	1	1	1	–	2	1	1	1	2	8	1	–	1	–	–	TQFP14-100	○	
S1C17622	56 x 4 52 x 8	8.2M	32.768k	2.7M	0.75	2.3	14	400	1.8 to 3.6 _{*1}	64K _{*6}	–	4K	47	3	3	1	1	1	1	–	2	1	1	1	2	8	1	–	1	–	–	TQFP15-128	○	
S1C17604	40 x 4 36 x 8	8.2M	32.768k	2.7M	0.75	2.3	14	400	1.8 to 3.6 _{*1}	128K _{*6}	–	8K	36	3	3	3	1	1	1	1	2	1	1	1	2	8	1	–	1	–	–	TQFP14-100	○	
S1C17624	56 x 4 52 x 8	8.2M	32.768k	2.7M	0.75	2.3	14	400	1.8 to 3.6 _{*1}	128K _{*6}	–	8K	47	3	3	3	1	1	1	1	2	1	1	1	2	8	1	–	1	–	–	TQFP15-128	○	
S1C17500 series	[Low Power] This is a 16-bit MCU with built-in flash memory, which realizes high-speed processing at low power consumption. This product is equipped with various												features, such as a general-purpose I/O port, A/D converter input and serial I/F, and is suitable for controlling various sensor built-in devices, including household appliances.																					
S1C17564	–	24M	32.768k	2M to 12M	0.8	2.7	16	450	2.0 to 5.5	128K _{*3}	–	16K	40	–	5	4	1	1	1	–	2	3	1	1	1	–	4	–	1	–	–	TQFP13-64 VFBA5H-81	○	
S1C17589	–	16.8M	32.768k	4M/8M/12M/16M	0.2	0.6	9	280	1.8 to 5.5	128K _{*4}	–	16K	88 68 52	–	6	4 x 6	–	1	–	1	3	2	1	1	–	16 11 7	1	1	–	–	–	QFP15-100 QFP14-80 QFP13-64	○ – –	
S1C17700 series	It is an application specialized series. It is a 16-bit MCU with Flash memory compatible with high processing while achieving low power consumption, supporting power supply voltages from 1.8 V to 5.5 V.																																	
S1C17711	64 x 16 56 x 24	8.2M	32.768k	2.7M	1.0	2.0	12	400	1.8 to 3.6 _{*1}	64K _{*6}	–	4K	29	–	4	4	1	1	1	–	1	1	1	1	2	8	1	–	1	–	–	TQFP15-128	○	
S1C17702	88 x 16 72 x 32	8.2M	32.768k	2.7M	1.0	2.5	16	450	1.8 to 3.6 _{*1}	128K _{*6}	–	12K	28	3	3	2	1	1	1	–	1	1	1	–	–	1	–	1	–	–	QFP21-176 VFBA10H-180 VFBA8H-181	○		
S1C17703	120 x 16/24/32 60 x 64	8.2M	32.768k	2.7M	1.0	2.5	15	450	1.8 to 3.6 _{*2}	256K _{*6}	–	12K	34	–	5	4	1	1	1	–	2	3	1	1	2	8	1	–	1	–	–	QFP21-216 VFBA10H-240	○	
S1C17705	128 x 16/24/32 64 x 64	8.2M	32.768k	2.7M	1.2	2.7	18	550	1.8 to 3.6 _{*2}	512K _{*6}	–	12K	35	–	5	4	1	1	1	–	2	3	1	1	2	8	1	–	1	–	–	VFBA10H-240	○	
S1C17800 series	[High Performance] This 16-bit MCU realized advanced processing equivalent to 32-bit. The built-in LCD controller provides maximum VGA monochrome displays. This product is equipped with abundant built-in I/F, such as USB, various serial interfaces												and A/D converters, suitable for operation panel control of white home appliances and various products, with improved user interface utilizing displays, music, sound, touch panels and etc.																					
S1C17801	LCD Controllers	48M	32.768k	–	1.4 _{*10}	12	–	6000	3.0 to 3.6	128K _{*6}	–	4K	99 97 69	6	2	1	–	1	–	1 _{*11}	1	2	1	–	1	–	8	–	Multiplier:○ Divider:×	–	BUS supported USB FS	TQFP15-128	–	
S1C17803	LCD Controllers	33M	32.768k	–	1.3 _{*10}	5	–	6500	2.7 to 5.5	128K _{*6}	–	16K	–	4	1	2	–	1	–	1 _{*11}	1	2 _{*12}	1	1	1	–	4	–	1	–	BUS supported	TQFP15-128 TQFP14-100	– –	

*1: During erasing / programming in flash memory (V_{DD}): 2.7V to 3.6 V
 *2: During erasing / programming in flash memory (V_{DD}): 2.5V to 3.6 V
 *3: During erasing / programming voltage in flash memory (V_{PP}): The external applying of 7.5V / 7.0V (Typ.) is needed.
 *4: During erasing / programming voltage in flash memory (V_{PP}): The external applying of 7.5V / 7.5V (Typ.) is needed.
 *5: SVD is an abbreviation for Supply Voltage Detector.
 *6: This product uses SuperFlash® technology licensed from SST UK Ltd.

*7: AI pad, Au bump
 *8: Including Input port and Output port.
 *9: Resolution: 12-bit

*10: Unmounted OSC1
 *11: The battery backed up operation is supported.
 *12: Universal serial interface (Any of UART, SPI and I²C functions can be selected.)

Products	Display	Operation clock			Supply current				Power supply	Memory			I/O							SIO					Analog			Others			Form of delivery		
	EPD Driver seg (TP/BP)	High-speed [Hz] (Max.)	Low-speed [Hz] (Typ.)	Built-in oscillator [Hz] (Typ.)	Sleep [μA] (Typ.)	RTC [μA] (Typ.)	32kHz Operating [μA] (Typ.)	1MHz operating [μA] (Typ.)	Supply voltage [V]	Flash ROM [Byte]	EEPROM [Byte]	RAM [Byte]	I/O port	8-bit timer	16-bit timer	16bit-PWM timer	Stopwatch	Watchdog timer	Clock	Real-time clock	UART	SPI	I ² C master	I ² C slave	Remote controller transmission and reception	RF converter (24-bit)	A/D converter	SVD*5	Multiplier/Divider	Temperature detection circuit	Package	Chip	
S1C17F50 series	[Medium and small segment EPD] The product also includes embedded features such as a real-time clock, theoretical regulation, a driver capable of wringing the maximum performance from segmented EPDs, and a temperature sensor. As a result, the device does not simply drive the display, but also corrects temperature effects that could harm display quality making it possible to maximize the characteristics of an e-paper display with a single chip.																																
S1C17F57	64 (2TP/2BP)	4.2M	32.768k	32k/500k/1M/2M	0.10	0.21	12	410	2.0 to 3.6	32K _{*2}	–	2K	29	2	–	2	1	1	1	1	1	1	1	–	1	–	1	1	1	1	–	–	○ _{*3}
S1C17F63	42 (1TP/1BP)	16.8M	32.768k	500k/700k/1M/2M/4M/8M/16M	0.45	0.11	5	305	1.8 to 5.5*5	32K _{*2}	256	2K	17	–	4	2 x 2	–	1	–	1	1	2	1	–	–	7	1	1	1	–	–	○ _{*3}	

*1: SVD is an abbreviation for Supply Voltage Detector.
 *2: During erasing / programming voltage in flash memory (V_{PP}): The external applying of 7.0V / 7.5V (Typ.) is needed. (*2) can be rewritten even with internal power supply.
 *3: AI pad, Au bump

*4: Including Input port and Output port.
 *5: During erasing / programming in flash memory / EEPROM programming (V_{DD}): 2.2V to 5.5V

global.epson.com/products_and_drivers/semicon/products/micro_controller/

On the Epson MCU website, you can access a variety of information required for device selection and design development.

Downloadable information

- Hardware Development Tool
- Software Development Tool
- Application Note
- Sample Program
- MP Support Tool

Microcontrollers Parametric Search

It's useful for your model selection of microcontrollers. You can download Data sheets, Technical manuals and Manual errata sheets.

Downloadable information

- Data sheets
- Technical manuals
- Manual errata sheets

Overall development environment

Things prepared by customers



*The screen is an integrated development environment
IAR Embedded Workbench for Arm manufactured by IAR Systems

Debug Probe
Supported products
- IAR Systems I-JET
- SEGGER J-LINK
etc.

Target board for product development

Offered from Epson

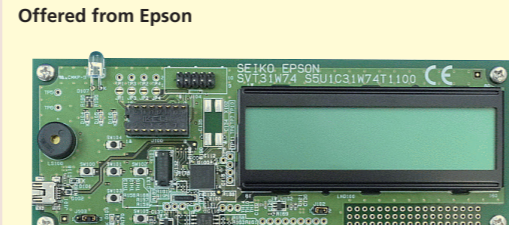

Initial evaluation target board

Integrated development environment
Supported products
- IAR Systems IAR Embedded Workbench for Arm
- Arm MDK-Arm
etc.

Offered from Epson



Model-specific information tool and Flash loader for integrated development environment

Sample program

Configuration tool for factory ROM write

Development support tool (Evaluation board)

- S1C31 chip built in
- Possible to evaluate the IC functions
- Provides a sample sources for various functions
- Debugging and Flash programming supported

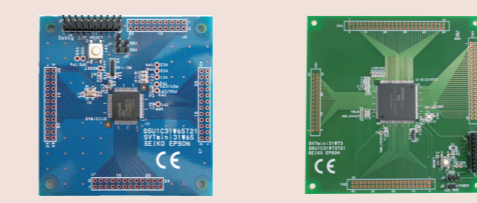

SVTmini31W65 **SVTmini31W73**

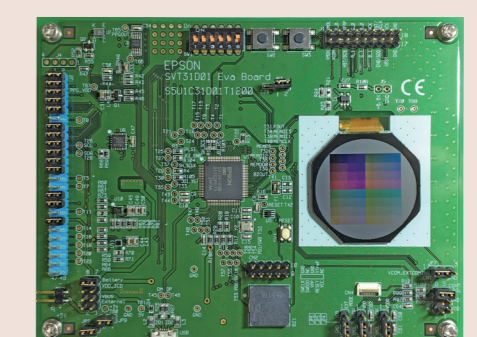

SVT31D01

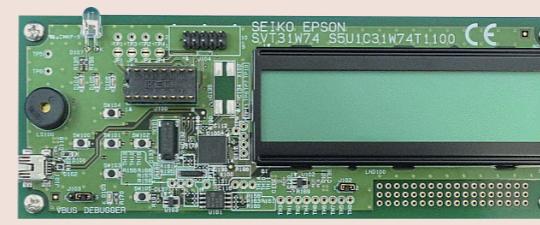

SVT31W74

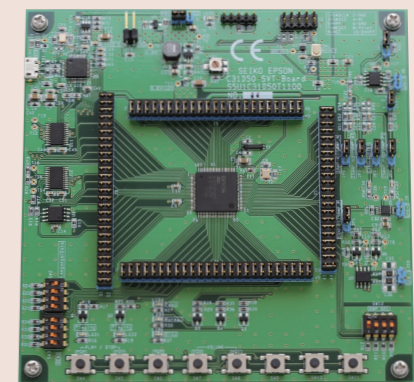

SVT31D50

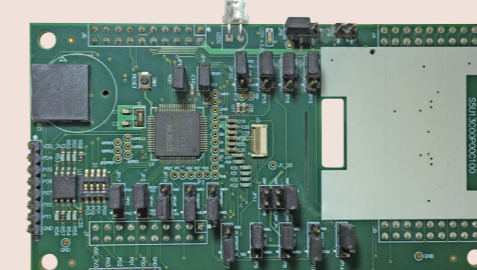

SVT13C00

Model Name	Product Name	Mounted Microcontroller Name	Remarks
SVTmini31W65	S5U1C31W65T2	S1C31W65	
SVTmini31W73	S5U1C31W73T2	S1C31W73	
SVT31W74	S5U1C31W74T1	S1C31W74	Dot matrix liquid crystal panel, Infrared LED, USB connector, Bridge Board
SVT31D01	S5U1C31D01T1	S1C31D01	Color memory display, Acceleration gyro sensor, Pulse sensor, Bridge Board
SVT31D50	S5U1C31D50T1	S1C31D50	AMP(class AB, class D), SPI-FLASH(8MB)
SVT13C00	S5U13C00K00C	S1D13C00	Color memory display, Bridge Board for connecting to Host CPU

3rd Party tool inquiries

Integrated Development Environment, Debug Probe

 IAR Systems K.K.
www.iar.com/buy/

Debug & Trace Probes, Flasher / In-Circuit Programmers

 SEGGER
The Embedded Experts
SEGGER Microcontroller GmbH
www.segger.com

GNU17 package

Optimized C compiler supporting 16MB space
Assembler, linker and ANSI library
GUI-based debugger
Eclipse integrated environment

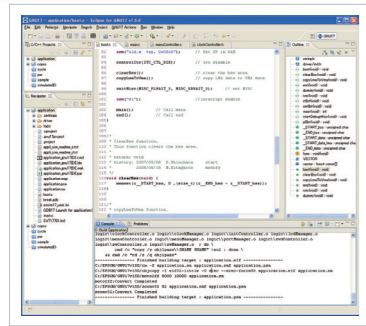

ICD mini

On-chip ICE, S1C17 Family products are supported.
Connect with the target board with 4 pins at minimum (3 signal pins and 1 GND pin).
Includes execution time measurement function.
Uses USB bus power.
Can be used as a Multi Programmer.
Includes firmware update function.
Power supply function for target devices of 3.3V.



Ver 3.0

GNU17



USB cable



ICD mini (SSU1C17001H)

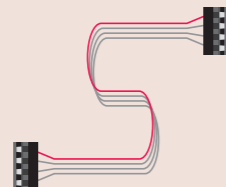

10-line cable (DCLK, DSIO, DST2, GND)

Starter / Beginner

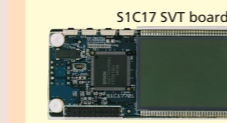

S1C17 SVT board

Initial evaluation target board

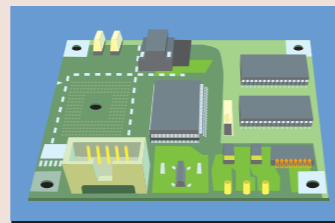

Target board for product development

Development support tool (Software simulator)

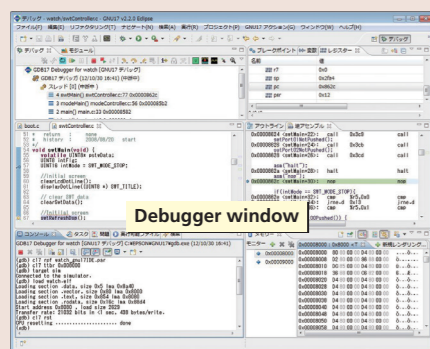

- Simulatable on PC including the LCD display, without using external debugging hardware or using an actual chip, it is possible to simulate only the LCD display (Custom-made LCD Panels can be created)
- Ability to show various data at the same time in multiple windows
- Ability to execute frequently using commands from the tool bar or menus
- Function of displaying C source, program code and symbols using disassembler
- Consecutive program execution and 3 types of step executions
- 3 types of break functions
- Trace and coverage functions
- Automatic command execution using command files

Development support tool (Evaluation board)

- S1C17 chip built in
- Possible to evaluate the IC functions
- Provides a sample software for various functions
- Debugging and Flash programming supported

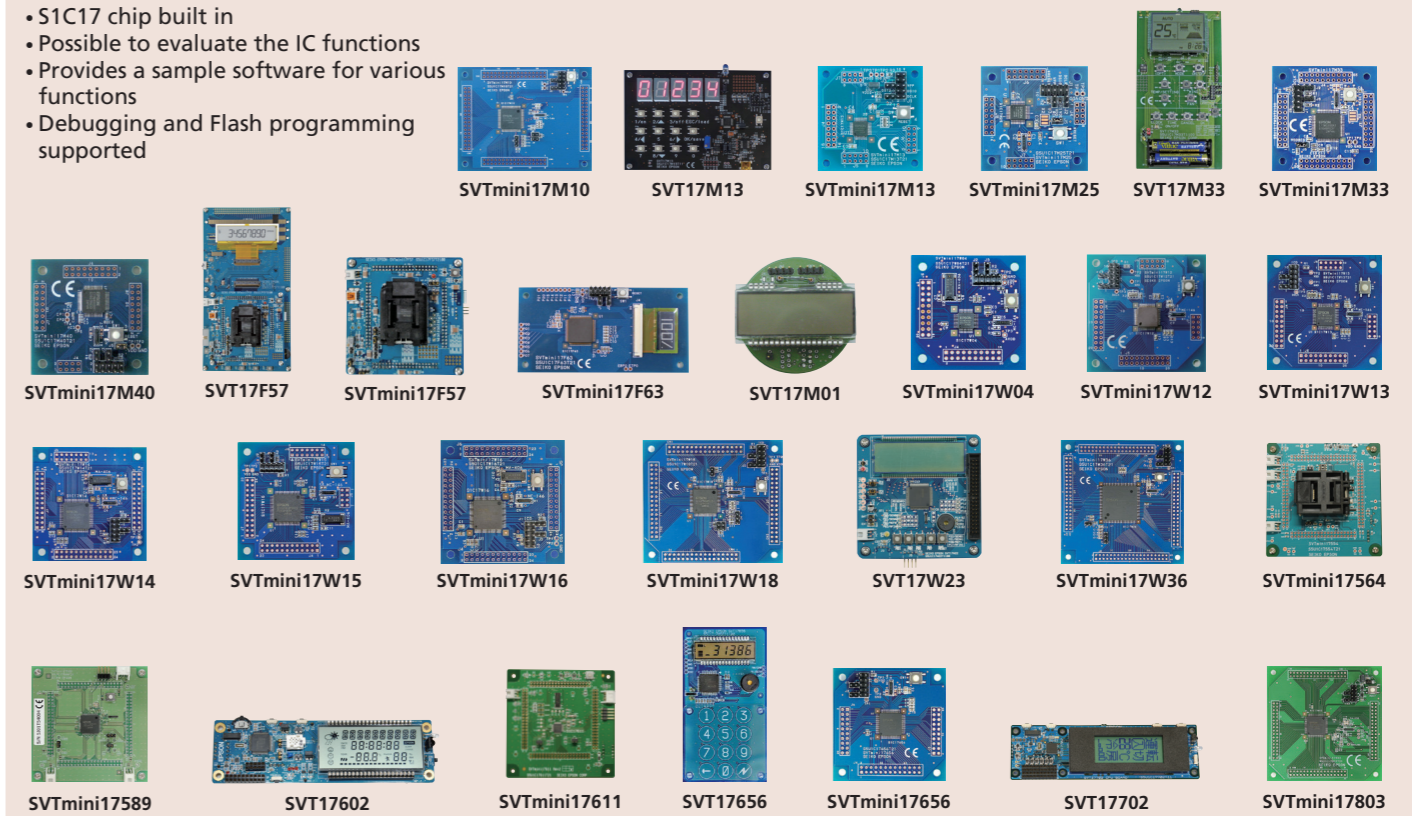

Model Name	Product Name	Mounted Microcontroller Name	Remarks
SVT17F57	S5U1C17F57T11	S1C17F57	Segment EPD panel
SVTmini17F57	S5U1C17F57T21	S1C17F57	
SVTmini17F63	S5U1C17F63T21	S1C17F63	Segment EPD panel
SVT17M01	S5U1C17M01T11	S1C17M01	LCD panel, MR Sensor with EEPROM
SVTmini17M10	S5U1C17M10T21	S1C17M10	
SVT17M13	S5U1C17M13T11	S1C17M13	7 seg LED 5 digits, EEPROM, Infrared LED, Key matrix 3x4
SVTmini17M25	S5U1C17M25T21	S1C17M25	
SVT17M33	S5U1C17M33T11	S1C17M33	Reference board of remote controller
SVTmini17M33	S5U1C17M33T21	S1C17M33	
SVTmini17M40	S5U1C17M40T21	S1C17M40	
SVTmini17M13	S5U1C17M13T21	S1C17M13	
SVTmini17W04	S5U1C17W04T21	S1C17W04	
SVTmini17W12	S5U1C17W12T21	S1C17W12	
SVTmini17W13	S5U1C17W13T21	S1C17W13	
SVTmini17W14	S5U1C17W14T21	S1C17W14	
SVTmini17W15	S5U1C17W15T21	S1C17W15	
SVTmini17W16	S5U1C17W16T21	S1C17W16	
SVTmini17W18	S5U1C17W18T21	S1C17W18	
SVT17W23	S5U1C17W23T11	S1C17W23	LCD panel, Piezoelectric buzzer
SVTmini17W36	S5U1C17W36T21	S1C17W36	
SVTmini17564	S5U1C17564T21	S1C17564	
SVTmini17589	S5U1C17589T21	S1C17589	
SVT17602	S5U1C17602T11	S1C17602	LCD panel, Remote control transmitter and receiver, Thermal/Humidity/Illuminance sensor
SVTmini17611	S5U1C17611T21	S1C17611	
SVT17656	S5U1C17656T11	S1C17656	LCD panel, Capacitive touch button, Piezoelectric buzzer
SVTmini17656	S5U1C17656T21	S1C17656	
SVT17702	S5U1C17702T11	S1C17702	LCD panel, Remote control transmitter and receiver
SVTmini17803	S5U1C17803T21	S1C17803	

■ If you procure written products from a Epson dealer

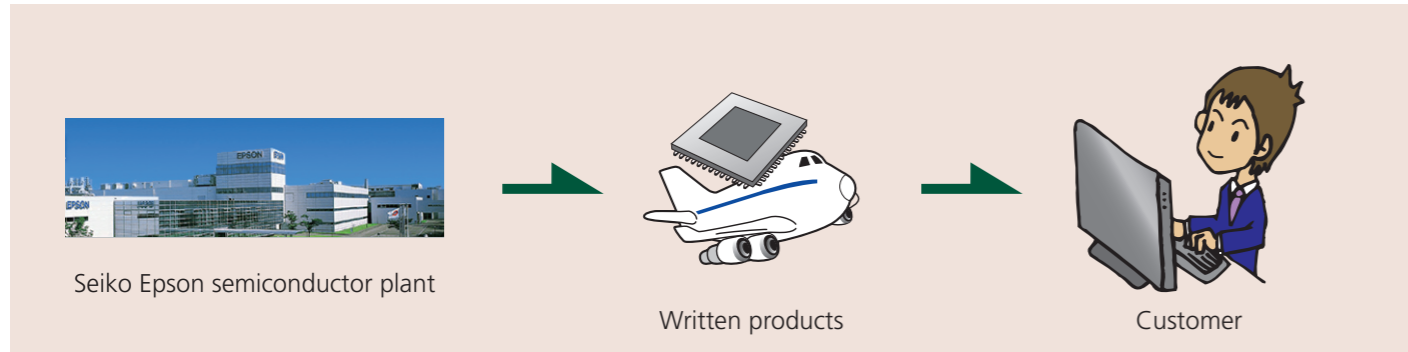

■ If you write to flash memory on your side (Single writing)

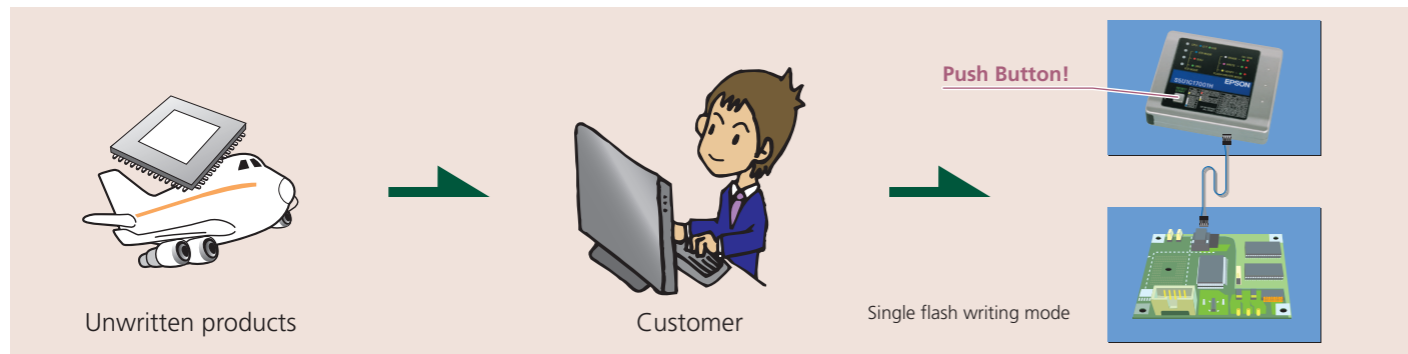

■ If you write to flash memory on your side (Simultaneous multiple writing)

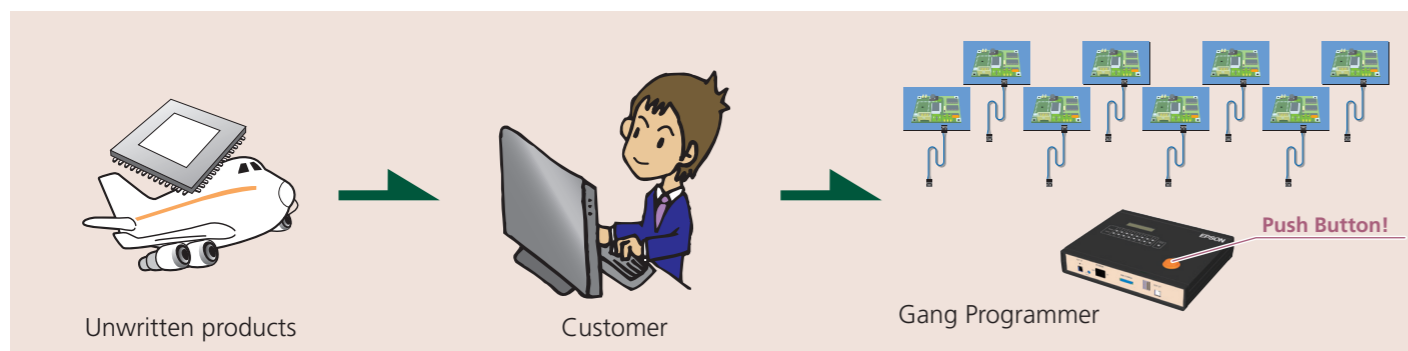
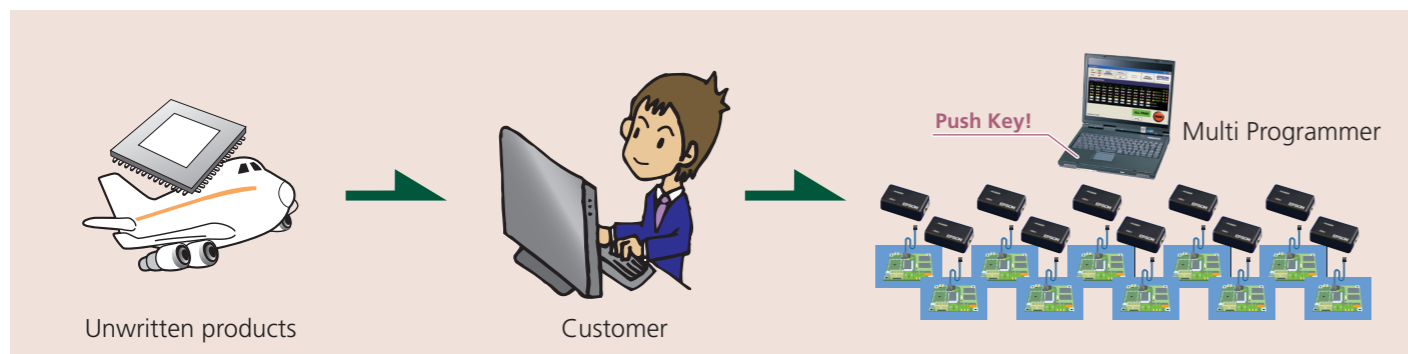

■ On-board writing tools and environments

Compatible models: S1C17Family(Single writing)

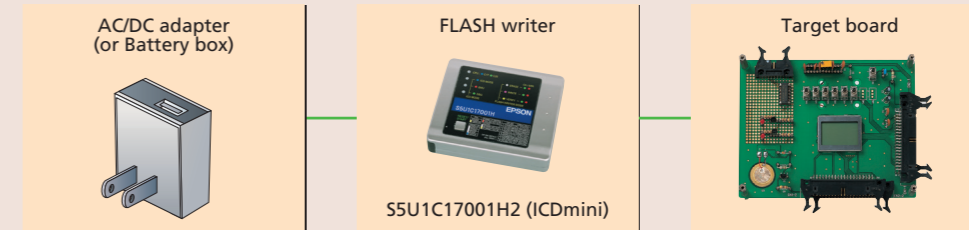

- A single S5U1C17001H2 (ICDmini) unit operates as an on-chip flash writer. Simply by pressing a button, user data previously saved in the ICDmini can be written to the internal flash ROM on the target board, or the flash ROM connected to the external bus.
- You can enjoy on-board programming easily at any location where a 5V power supply is available.
- * Power supply to the target board may be required separately.
- * The product does not include the target board, and AC adapter or battery box to supply power to USB terminals.

Compatible models: S1C17Family(Simultaneous multiple writing)

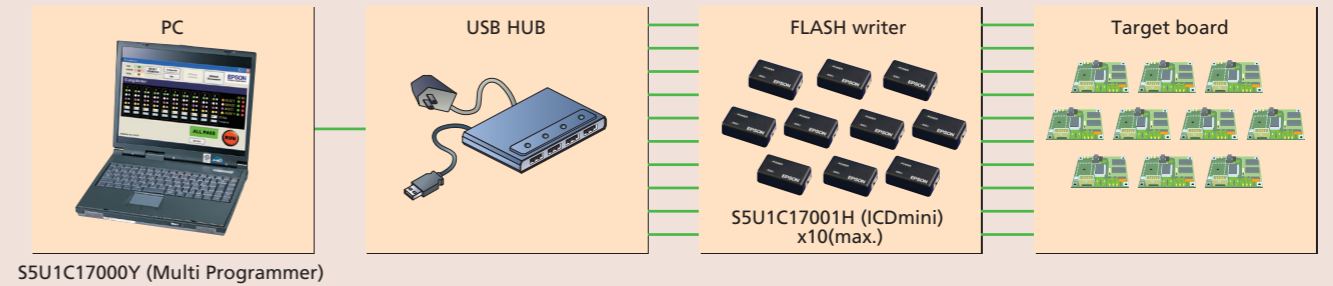

- Up to 10 units of the S5U1C17001H (ICDmini) can be used to construct an environment enabling user data to be downloaded simultaneously to multiple targets.
- The S5U1C17000Y, Multi Programmer software that controls the ICDmini, provides user-friendly screen and simple operation.
- * Power supply to the target board may be required separately.
- * The product does not include the target board, PC and the USB hub operating on self-power.

Compatible models: S1C17Family(Simultaneous multiple writing)













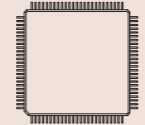

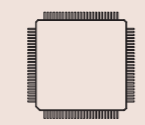
- A single S5U1C1700W unit downloads user data simultaneously to maximum 8 targets.
- SD card is used to input user data, and the operating status can be checked by LCD, LED and buzzer.
- A serial number writing function is also built-in.

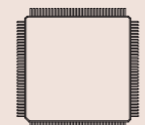
Compatible models: S1C31Family(Single writing)

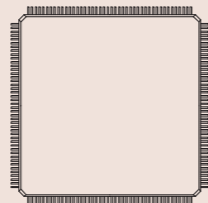

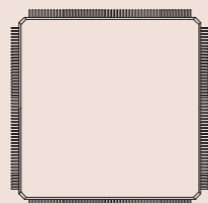
- SEGGER J-Link or Flasher / Any debug probe or flash programmer that supports J-Flash software tool can be used.



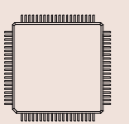
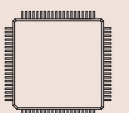

QFP & TQFP & SQFN

PKG type/Pin count	Body size (mm)	Lead pitch (mm)	PKG type/Pin count	Body size (mm)	Lead pitch (mm)
SQFN4-24 (P-VQFN024-0404-0.50) 	4 X 4 X 1.0	0.5	QFP15-100 (P-LQFP100-1414-0.50) 	14 X 14 X 1.7	0.5
SQFN5-32 (P-VQFN032-0505-0.50) 	5 X 5 X 1.0	0.5	TQFP14-100 (P-TQFP100-1212-0.40) 	12 X 12 X 1.2	0.4
TQFP12-32 (P-TQFP032-0707-0.80) 	7 X 7 X 1.2	0.8	TQFP15-128 (P-TQFP128-1414-0.40) 	14 X 14 X 1.2	0.4
QFP12-48 (P-LQFP048-0707-0.50) 	7 X 7 X 1.7	0.5	QFP21-176 (P-LQFP176-2424-0.50) 	24 X 24 X 1.7	0.5
SQFN7-48 (P-VQFN048-0707-0.50) 	7 X 7 X 1.0	0.5	QFP21-216 (P-LQFP216-2424-0.40) 	24 X 24 X 1.7	0.4
TQFP12-48 (P-TQFP048-0707-0.50) 	7 X 7 X 1.2	0.5			
SQFN9-64 (P-VQFN064-0909-0.50) 	9 X 9 X 1.0	0.5			
QFP13-64 (P-LQFP064-1010-0.50) 	10 X 10 X 1.7	0.5			
TQFP13-64 (P-TQFP064-1010-0.50) 	10 X 10 X 1.2	0.5			
TQFP14-80 (P-TQFP080-1212-0.50) 	12 X 12 X 1.2	0.5			
QFP14-80 (P-LQFP080-1212-0.50) 	12 X 12 X 1.7	0.5			

WCSP

PKG type/Pin count	Body size (mm)	Ball pitch (mm)
WCSP-96 (S1C31D01) 	4.5 X 4.5 X 0.7	0.4

Compact BGA (PFBGA) & Thin type BGA (VFBGA)

PKG type/Pin count	Body size (mm)	Ball pitch (mm)
VFPGA5H-81 (P-VFBGA-081-0505-0.50) 	5 X 5 X 1.0	0.5
VFPGA10H-180 (P-VFBGA-180-1010-0.65) 	10 X 10 X 1.0	0.65
VFPGA8H-181 (P-VFBGA-181-0808-0.50) 	8 X 8 X 1.0	0.5
VFPGA10H-240 (P-VFBGA-240-1010-0.50) 	10 X 10 X 1.0	0.5

QFP

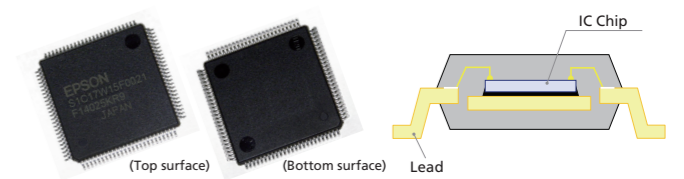

SQFN

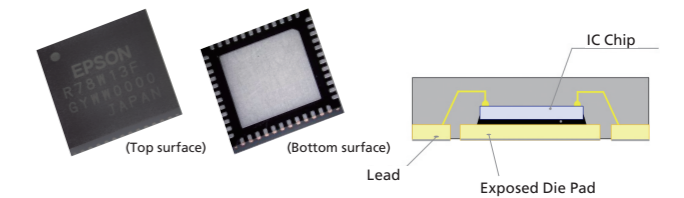

WCSP

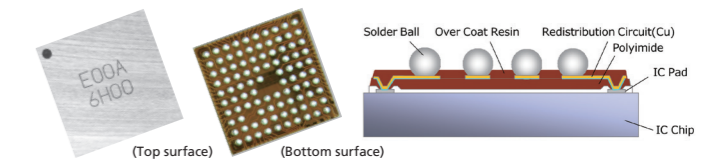

Thin type BGA (VFBGA)

