

Customer : _____ Ver. No		XB5-1102-749E(00)
	Date issued	11-Jul-08

SPECIFICATION FOR APPROVAL THE PIEZOELECTRIC SOUNDER

YOUR CONFIRMATION	
Date	

TYPE :PS2220P02



TDK XIAMEN CO., LTD.
 SENSORS & ACTUATORS MANUFACTURE DEPT.
 XIAMEN PLANT : 321~339 TONGJI SOUTH ROAD ,
 JIMEI DISTRICT, XIAMEN, CHINA
 TEL : 0086-592-6150333 EXT.129

APPROVED	CHECKED	REPORTED

1. Scope

This specification is applicable to the Piezoelectric Sounder of TDK.

2. Product name

The nomenclature of the product specified by this specification shall be Piezoelectric Sounder

Part name : P S 2 2 2 0 P 0 2

Contents of this specification as below :

Contents	Item	Page
2-1. Structure and Dimensions	XB5-1102-749E-(00)-03	2
2-2. Inspected Circuit	XB5-1102-749E-(00)-04	3
2-3. Specification of the Characteristics	XB5-1102-749E-(00)-05	3
2-4. Environmental Test	XB5-1102-749E-(00)-06	4、5
2-5. Inspection standard	XB5-1102-749E-(00)-07	5
2-6. Cautions for use	XB5-1102-749E-(00)-08	5、6、7
2-7. Others	XB5-1102-749E-(00)-09	7

Revision	Version	Date	Revised by	Modified Item	
Corporation (Department)				Date issued	Ver. No.
TDK XIAMEN CO.,LTD(Sensors & Actuators Manufacture Dept.)				11-Jul-08	XB5-1102-749E-(00)

3. Structure and Dimensions

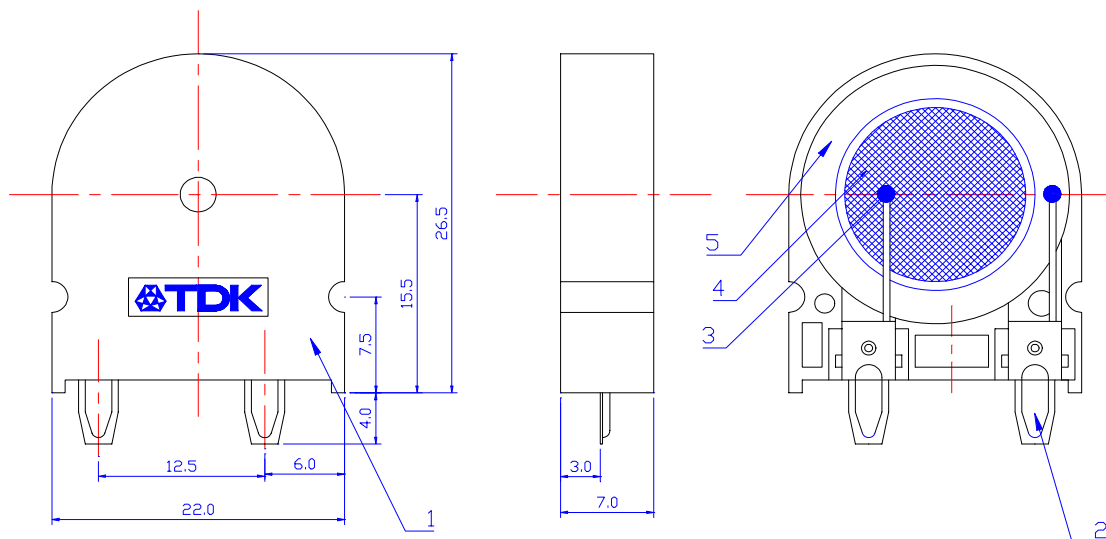

Unit : mm

General tolerance : ±0.3

Part table

NO.	Name	Material,etc.
1	Outer casing	PBT (Black)
2	Terminals	Bronze
3	Solder	Sn-Ag-Cu
4	Vibrator	Piezoelectric Ceramic
5	Vibrating sheet	Brass

4. Inspected Circuit

OSC: Signal Generator

2.0±0.05KHz 3V_{o-p}

50% duty square-wave

Output Impedance: 50Ω

FC: Frequency Counter

V : High-frequency Voltage Meter

R : Sampling Resister , 10Ω

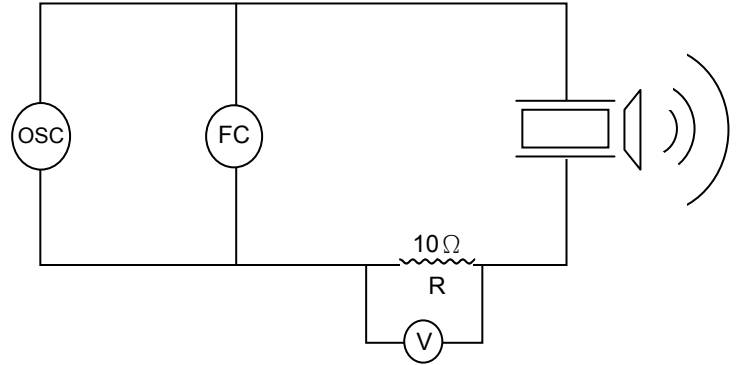

5. Specifications of the Characteristics

Item	Specifications	
5-1. Appearance	Free from marked flaws, contaminants and deformation, etc.	
5-2. Test Condition	5.2.1 Drive frequency	2.0±0.05KHz (50% duty square-wave)
	5.2.2 Drive voltage	3V _{o-p}
	5.2.3 Measuring distance	10cm
5-3. Sound Pressure	70dB Min/10cm (Under condition per 5-2)	
5-4. Operating temperature	-40°C ~ +125°C (see 6-1 & 6-2)	
5-5. Storage temperature	-20°C ~ +70°C	

6.Environmental Test

Item	Specifications
6-1. Exposure to high temp.	at +125°C for 240 hours
6-2. Exposure to low temp.	at -40°C for 240 hours
6-3. Thermal shock test	Submit to 25 cycles of the following sequence conditions in air : -40°C , 0.5Hr +125°C , 0.5Hr
6-4. Exposure to humidity	60°C ,at 90~95%RH for 240 hours.
6-5. Vibration	10~55~10Hz, total amplitude 1.52mm one minute sweep /1 cycles X,Y,Z axis for two hours respectively.
6-6. Impact	Apply 100G for three times for X,Y,Z axis respectively.
6-7. Dropping	Dropped two times freely on a lauan plate from the height of 75cm.
6-8. Solderability	245°C for 5 seconds .Flux and a plate in 1.6mm thick are used for this test.
6-9. Resistance to soldering heat	350°C for 3 seconds .Flux and a plate of 1.6mm thick are used for this test.
6-10. Continuous operation	Apply 50% duty square wave 20V _{o-p} 2.0KHz for 240 hours.

- 8.3 The sounder and unimorph have been designed for indoor use. Outdoor use may introduce humidity or moisture. In the event moisture enters the sounder, it may no longer operate properly. In applications that the sounder needs to be used under an environment with the possibility of water getting into sound outlet, it is important waterproofing measures are taken.
- 8.4 If the sounder and unimorph need to be cleaned, then ensure that no solvent or gas enters the sound outlet. If solvent enters the sounder through the sound outlet, the solvent may remain inside for many hours and cause the product's malfunction.
- 8.5 The sound generator in the sounder is composed of a 100-micron piezoelectric ceramic. So it is essential that the sound generator not be touched with a power supply pin or similar through the sound outlet, otherwise the ceramics may be damaged. Furthermore,, it is important that the sounder is placed in storage boxes or containers, ensuring proper stacking.
- 8.6 The sounder and unimorph body should never be exposed to mechanical stress, otherwise the casing may be deformed, thereby causing possible failure.
- 8.7 The performance of the sounder is influenced by its surroundings and therefore it is important that the sounder should be used in such a way that no other parts or cover is placed very close to the sound outlet opening.

- 8.8 Do not use the sounder and the unimorph for a long time in a corrosive gas (such as H₂S), otherwise the parts of the sounder may corrode, and no longer operate properly.
- 8.9 Handle the sounder with care ,and not drop them carelessly.
- 8.10 This sounder is not recommended for automotive applications.
- 8.11 Do not directly hand touch leads of the unimorph, as this may start corrosion .
- 8.12 Do not let flux enter the sounder when soldering , if it enters around the contact area ,it may result in a bad conductive joint.

9. Others

- 9.1 If the event of discrepancies in the interpretation of the contents of this specification , an agreement shall be sought through consultation between the customer and the vendor.
- 9.2 In the event of changes in design and processes or interruption of manufacture, notification shall be submitted in advance for approval.